

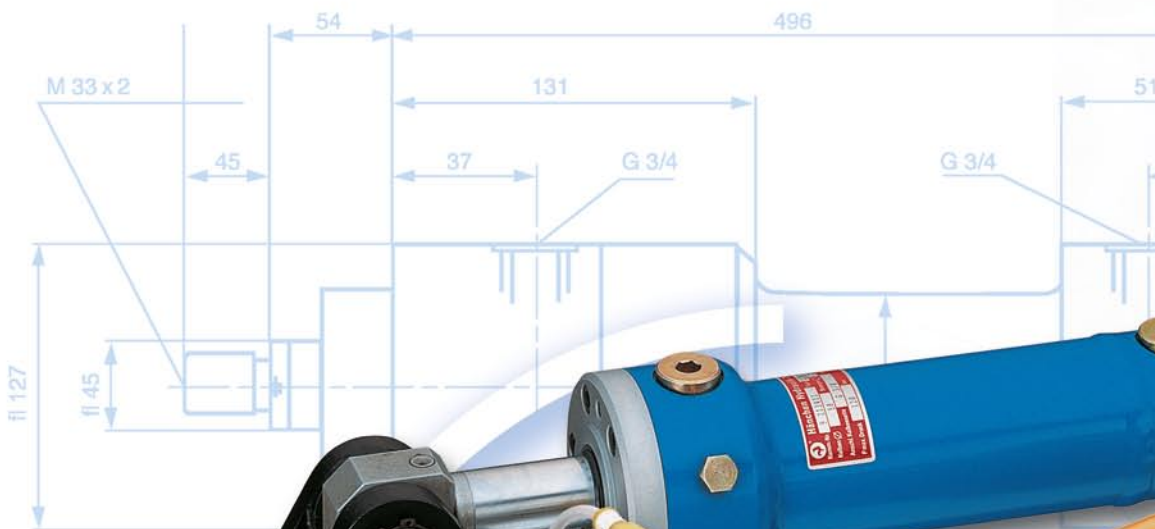

**HÄNCHEN**®

## HYDRAULIC CYLINDERS

- Hänchen standard cylinders
- Hänchen normalised cylinders
- with proximity sensors



*... simply good.*

## The finest way to treat hydraulic cylinders: Hänchen quality



Everyone who has heard of Hänchen is aware that its world-wide reputation is based on hydraulic cylinder solutions that are anything but standardised. The standardisation per se actually deals with nothing more than basic dimensions and connections, mounting parts etc. Indeed for this or that solution, the choice of a standard cylinder will often do the job without any problems. Upon closer inspection however, one will draw his/her own conclusions from what is an obvious difference and reconsider, because the standard Hänchen cylinder – by virtue of its size alone – offers advantages which tip the balance in its favour.

**Inside, outside – it's all there: right down to the last screw.** With the decision in favour of Hänchen hydraulic cylinders, the exhaustive and expensive development of mounting

parts or procurement difficulties are relegated to a thing of the past. Hänchen delivers a wide range of mounting part products, including the attendant accessories:

- Feet mounting
- Rod eyes with spherical plain bearing, with male or female threads
- Rod clevises
- Plain rod eyes
- Threaded flanges, with male or female threads
- Balls
- Trunnion mountings
- Brackets for trunnion mountings
- Brackets for swivel-bearing mountings
- Round or square-type mounting flanges
- Venting set
- „Minimess“ miniature coupling
- Hook wrench



## There is no norm for quality

As far as Hänchen is concerned there is no reason to look to another quality standard other than its own for its normalised cylinders in the Hänchen range of products. In other words, they benefit from the company's quality aspirations.

In principle, Hänchen makes exclusive use of honed cylinder tubes for all its cylinders.

Hänchen also guarantees that all the cylinders in its product range, as well as normalised cylinders, comply with the most

exact of geometrical accuracies.

In technical terms this means: the piston rods are covered with a particularly thick chromium coating (hard-chromium plated with at least 25 – 100 µm across the entire length) whereupon they are then honed again. The effort involved is indeed quite extensive, but the years of experience using this technology serve only to confirm the company's decision to use the finest materials and methods to achieve the best quality. The user therefore receives the typical quality associated with Hänchen cylinders even if normalised cylinders are to be installed.

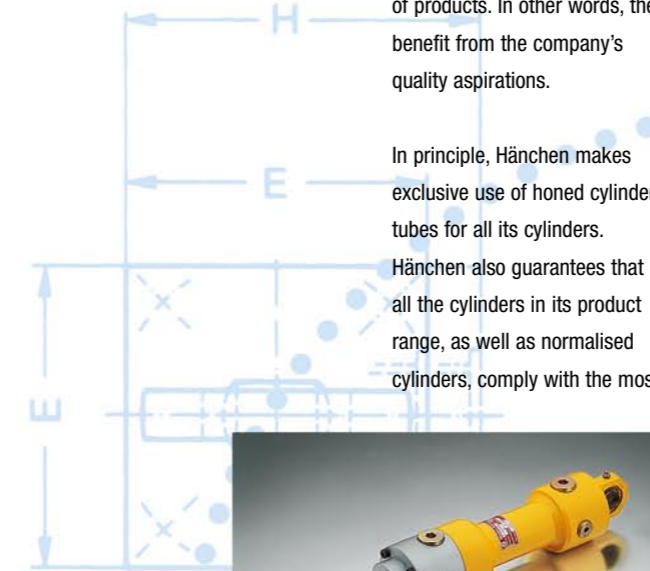

## For particularly high requirements: Servocop®

All Hänchen cylinders, including all those in the normalised series are also available in Servocop® quality in particular as low-friction versions: for extremely low piston speeds and low stick-slip movement.

Furthermore, Hänchen cylinders are also available with electronic components.

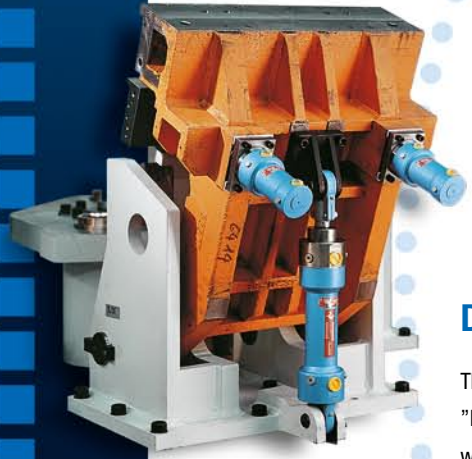

### David and Goliath

They really do exist, the "Davids" ... the small people, who can hold their own with their larger counterparts. This, however, should not be interpreted to mean that there's no real need for bigger cylinders. It is not without reason that Hänchen also has a comprehensive range of normalised cylinders of the 100, 160 and 250 series alongside its series 120 and 300 cylinders which comply with Hänchen standards.

**Here we have two "identical" cylinders: equally good, equally strong.**

- With exceptionally long service life
- With very low wear
- With extremely low friction
- With outstanding efficiency
- With ideal availability
- With extremely long service intervals
- With service-friendly features

**Where is the difference?**

- Different size
- Different shape
- Unequal weight
- Divergent value-for-money factor

- Compact
- Smaller
- Lightweight
- Better value-for-money factor

Hänchen standard cylinders

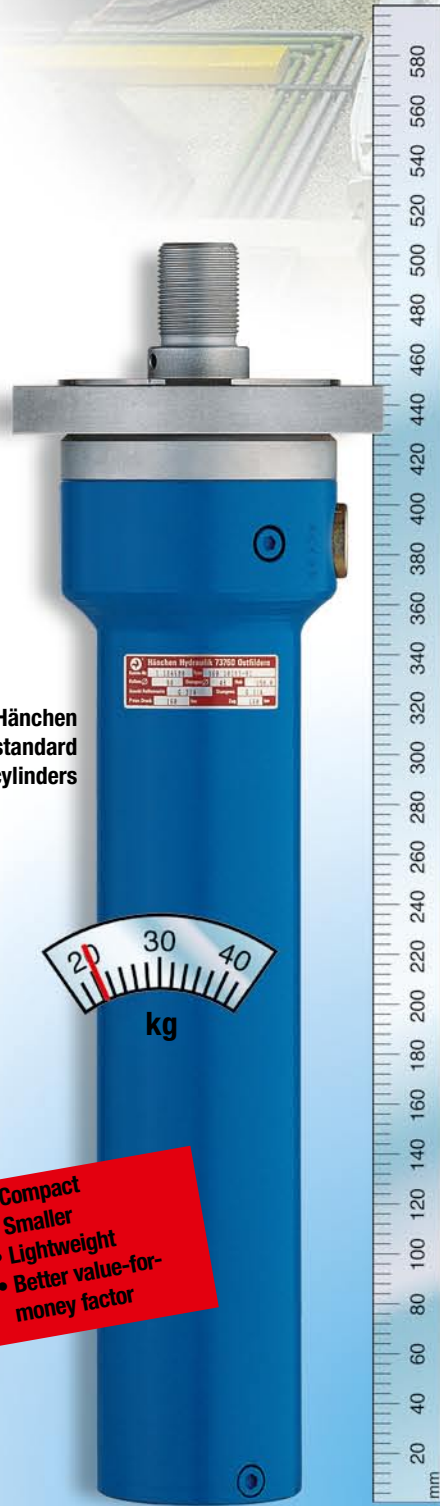

Hänchen normalised cylinders

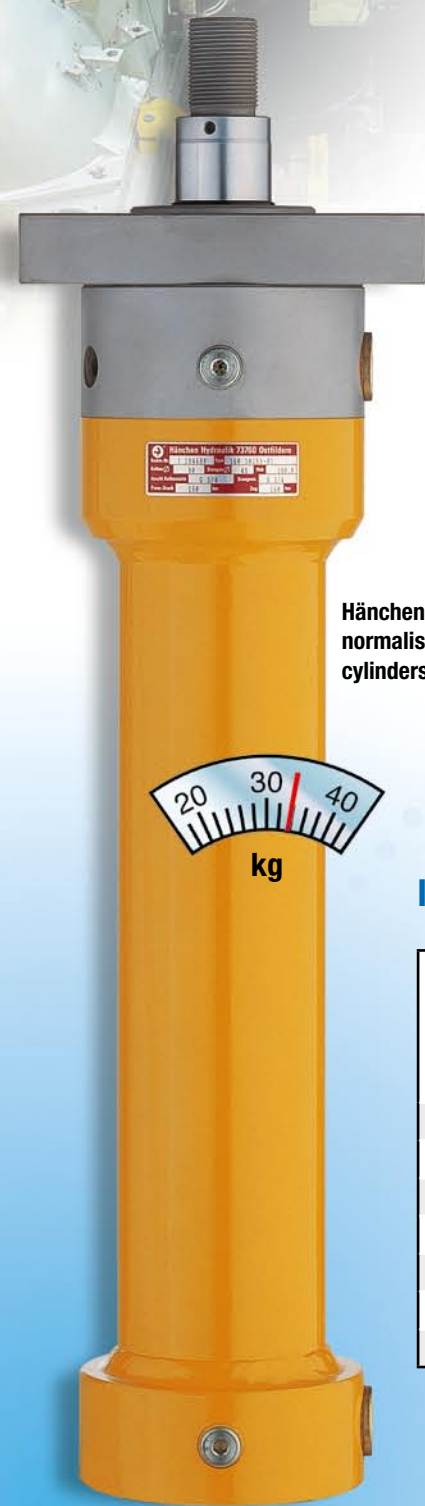

**Technical data**

Cylinders	Piston-Ø	Forces	Stroke up to
<b>Standard-cylinders with/without end-position cushioning</b>			
<b>Serie 120 (150 bar)</b>	12 - 600 mm	1 - 6000 kN	6000 mm
<b>Serie 122* (150 bar)</b>	12 - 300 mm	10 - 1500 kN	6000 mm
<b>Standard-cylinders with/without end-position cushioning</b>			
<b>Serie 300 (300 bar)</b>	25 - 600 mm	10 - 9000 kN	6000 mm
<b>Serie 302* (300 bar)</b>	25 - 300 mm	10 - 2500 kN	6000 mm
<b>Normalised cylinders</b>			
<b>Serie 100/102* (100 bar) as under DIN 24336</b>	25 - 200 mm	4.9 - 314 kN	6000 mm
<b>Normalised cylinders medium</b>			
<b>Serie 160 / 162* (160 bar) as under DIN ISO 6020-1</b>	25 - 200 mm	7.9 - 503 kN	6000 mm
<b>Normalised cylinders compact</b>			
<b>Serie 660 / 662* (160 bar) as under DIN 24554 / ISO 6020-2</b>	25 - 200 mm	7.9 - 503 kN	1500 mm
<b>Normalised cylinders</b>			
<b>Serie 250 / 252* (250 bar) as under DIN 24333 / ISO 6022</b>	50 - 200 mm	49 - 785 kN	6000 mm

\* with proximity sensors

**In comparison:**

	Hänchen standard cylinders Series 120	Hänchen normalised cylinders Series 160
Piston Ø	80 mm	80 mm
Piston rods Ø	40 mm	45 mm
Operating pressure max.	150 bar	160 bar
Weight	20.4 kg	33.9 kg
Overall length	505 mm	595 mm
Useful force F <sub>1</sub> at 150 bar	75.4 kN	75.4 kN
Useful force F <sub>2</sub> at 150 bar	56.5 kN	51.5 kN

## Hydraulic cylinders with proximity sensors and built-in „crash safety“

If there is a need for signalling in conjunction with Hänchen hydraulic cylinders, the pressure-resistant, inductive proximity sensors are not far away: depending upon the task at hand they go into action when specific consequential processes are triggered, they monitor functions (with additional diagnosis output), display enabled or disabled states, coordinate switching points.

Without proximity sensors and subject the cylinder to a none of this would be possible. They are specifically matched for Hänchen hydraulic cylinders in each respective application

and subject the cylinder to a permanent visual control and display at which end position the piston is located at any given time. Proximity sensors switch at each respective stroke end position and thus the user knows "exactly what's what".

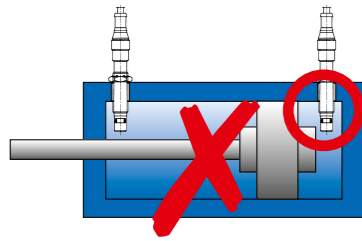

A „depth stop“ prevents the possibility of a crash: Hänchen's proximity sensors cannot be screwed in any further than prescribed.

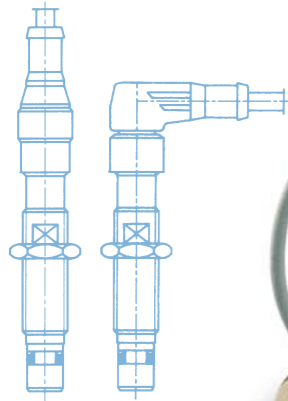
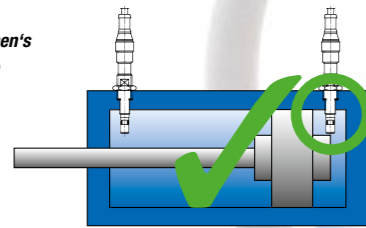

## The little guardian

All cylinders for proximity sensors have integrated end position damping at both sides, which can be disabled by opening the adjusting screw. For specific products such as the Ratio-Clamp® clamping unit or test cylinders, these proximity sensors demonstrate that alongside their actual task of monitoring, they also serve to provide greater safety.

## No more need for use-by date

The proximity sensor operates inductively and thus without making contact. This makes it free from wear-and-tear and enables it to operate flawlessly for an entire cylinder service life. And what's more, they can be fitted into any Hänchen hydraulic cylinder.

## Accessories

- Right-angle plug with cable
- Plug with straight terminal and cable

## Technical data

- Inductive
- Pressure resistant up to 500 bar
- Operating voltage 10 - 30 VDC
- Protective system as under DIN 40050: IP 67
- Operating temperature -25 to +70 °C

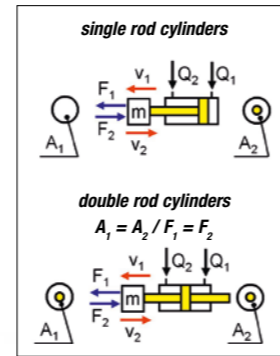

Forces of Hänchen hydraulic cylinders																			
Piston Ø [mm]	Piston rod Ø [mm]	A <sub>1</sub> [cm <sup>2</sup> ]	A <sub>2</sub> [cm <sup>2</sup> ]	Series 120 120 bar		Series 120 150 bar		Series 120 200 bar		Series 300 300 bar		DIN 24336		ISO 6020-1		ISO 6022		ISO 6020-2	
				F <sub>1</sub> [kN]	F <sub>2</sub> [kN]	F <sub>1</sub> [kN]	F <sub>2</sub> [kN]	F <sub>1</sub> [kN]	F <sub>2</sub> [kN]	F <sub>1</sub> [kN]	F <sub>2</sub> [kN]	F <sub>1</sub> [kN]	F <sub>2</sub> [kN]	F <sub>1</sub> [kN]	F <sub>2</sub> [kN]	F <sub>1</sub> [kN]	F <sub>2</sub> [kN]	F <sub>1</sub> [kN]	F <sub>2</sub> [kN]
16	6	2.0	1.7	2.4	2.1														
16	8	2.0	1.5	2.4	1.8														
20	10	3.1	2.4	3.8	2.8														
25	12	4.9	3.8	5.9	4.5	7.4	5.7					4.9	3.8					7.9	6.0
25	14	4.9	3.4											7.9	5.4				
25	16	4.9	2.9			7.4	4.3			14.7	8.7								
25	18	4.9	2.4															7.9	3.8
32	14	8.0	6.5									8.0	6.5					12.9	10.4
32	16	8.0	6.0			12.1	9.0												
32	18	8.0	5.5											12.9	8.8				
32	20	8.0	4.9							24.1	14.7								
32	22	8.0	4.2															12.9	6.8
40	18	12.6	10.0									12.6	10.0					20.1	16.0
40	20	12.6	9.4			18.8	14.1												
40	22	12.6	8.8											20.1	14.0				
40	25	12.6	7.7			18.8	11.5			37.7	23.0							20.1	10.3
40	28	12.6	6.4																
40	30	12.6	5.5							37.7	16.5								
50	22	19.6	15.8									19.6	15.8					31.4	25.3
50	25	19.6	14.7			29.5	22.1												
50	28	19.6	13.5											31.4	21.6				
50	30	19.6	12.6			29.5	18.8			58.9	37.7							49.1	29.0
50	32	19.6	11.6																
50	36	19.6	9.5															31.4	15.1
50	40	19.6	7.1							58.9	21.2								
60	30	28.3	21.2			42.4	31.8												
60	40	28.3	15.7			42.4	23.6			84.8	47.1								
60	50	28.3	8.6							84.8	25.9								
63	28	31.2	25.0									31.2	25.0					49.9	40.0
63	36	31.2	21.0											49.9	33.6				
63	40	31.2	18.6															77.9	46.5
63	45	31.2	15.3															49.9	24.4
80	36	50.3	40.1									50.3	40.1					80.4	64.1
80	40	50.3	37.7																
80	45	50.3	34.4			75.4	56.5							80.4	55.0				
80	50	50.3	30.6			75.4	45.9			150.8	91.9							125.7	76.6
80	56	50.3	25.6															80.4	41.0
80	60	50.3	22.0							150.8	66.0								
100	45	78.5	62.6									78.5	62.6					125.7	100.2
100	50	78.5	58.9			117.8	88.4												
100	56	78.5	53.9											125.7	86.3				
100	60	78.5	50.3			117.8	75.4			235.6	150.8								
100	63	78.5	47.4															196.3	118.4
100	70	78.5	40.1															125.7	64.1
100	80	78.5	28.3							235.6	84.8								
125	56	122.7	98.1									122.7	98.1					196.3	156.9
125	60	122.7	94.4			184.1	141.7												
125	70	122.7	84.2											196.3	134.8				
125	80	122.7	72.5			184.1	108.7			368.2	217.4							306.8	181.1
125	90	122.7	59.1															196.3	94.6
125	100	122.7	44.2							368.2	132.5								
140	80	153.9	103.7			230.9	155.5												
140	100	153.9	75.4			230.9	113.1			461.8	226.2								
160	80	201.1	150.8			301.6	226.2												
160	90	201.1	137.4											321.7	219.9				
160	100	201.1	122.5			301.6	183.8			603.2	367.6							502.7	306.3
180	100	254.5	175.9			381.7	263.9												
180	120	254.5	141.4			381.7	212.1			763.4	424.1								
200	100	314.2	235.6					628.3	471.2										
200	110	314.2	219.1											502.7	350.6				
200	120	314.2	201.1					628.3	402.1										
200	125	314.2	191.4															785.4	478.6
200	140	314.2	160.2							942.5	480.7								
220	120	380.1	267.0					760.3	534.1										
220	140	380.1	226.2					760.3	452.4										
220	160	380.1	179.1							1140.4	537.2								
250	120	490.9	377.8					981.7	755.6										
250	140	490.9	336.9					981.7	673.9										
250	180	490.9	236.4							1472.6	709.2								
300	160	706.9	505.8					1413.7	1011.6										
300	200	706.9	392.7							2120.6	1178.1								

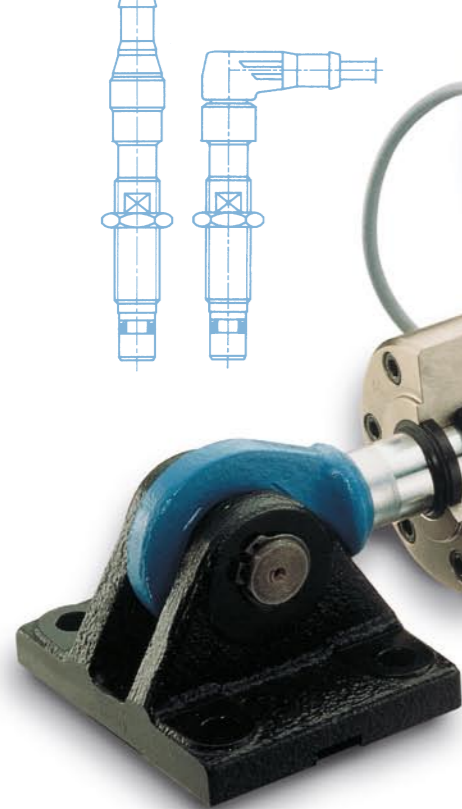

## Ratio-Drive® – the Hänchen system solutions that are tailored-made for individual applications

Do you want to achieve specific movements and speed profiles, or to move to any given position extremely precisely and reproducibly? Ratio-Drive® from Hänchen provides you with the ready-to-use solution for such situations – plug-and-play. Ratio Drive® is a self-contained, high-performance, safe and reliable linear drive for practi-

cally any application area. It is a combination of „standardised“ components and relevant mechatronic services ranging from design, project planning, software consulting and integration into a superordinate control system right through to on-site commissioning.

## Why search endlessly? The E-Kat from Hänchen contains the whole range

You need the perfect hydraulic linear drive solution, or absorbers? You require hydraulic cylinders in general mechanical engineering and special mechanical engineering or test cylinders for the simulation of real situations? In the electronic catalogue from Hänchen you will find all you need.

From individual cylinder components (normalised parts and Hänchen standards), the clamping unit Ratio-Clamp®, absorber elements and industrial shock absorbers, electronic components, proximity sensors and matching connectors as well as attachment/mounting parts to the final bolt, here you will find all components your customised solution comprises. **For your safety: all parts have undergone quality and functional tests and match perfectly.**



**HÄNCHEN®**

**Herbert Hänchen GmbH & Co. KG**  
Brunnwiesenstr. 3 · 73760 Ostfildern  
Postfach 4140 · 73744 Ostfildern  
Fon +49 711 44139-0  
Fax +49 711 44139-100  
info@haenchen.de

[www.haenchen.de](http://www.haenchen.de)

*simply good.*