

Herzeman
 AM GROUP

Quiet Internal Gear Pump

GA and GPA Series 30

General description

Fixed displacement internal gear pumps that can be driven by fixed or variable speed prime movers. Available in single, double, triple and quadruple configuration to suit a wide variety of applications.

Basic characteristics

Displacements	1.7 to 63 cm ³ per single pump or section
Max. pressure	100 bar
Max. speed	up to 4000 rev/min
Types	single and multiple models

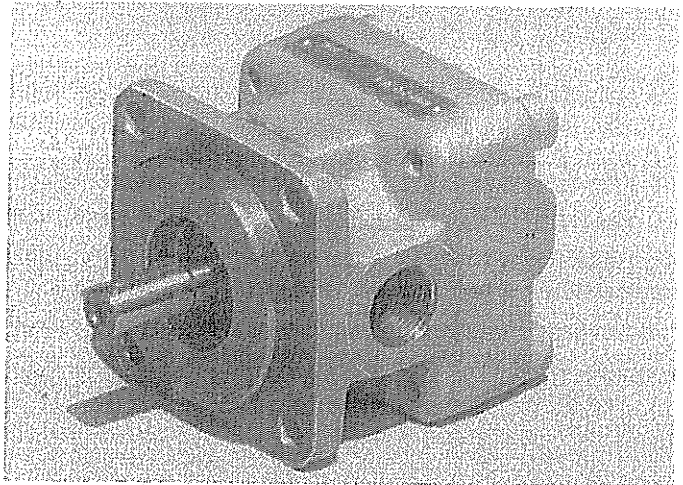

Features

- Quietness
- Internal pressure relief valve option
- Heavy duty bearing option for indirect drives
- Choice of ISO metric or SAE mounting
- Choice of clockwise or counter-clockwise rotation
- G(BSPF) threaded ports

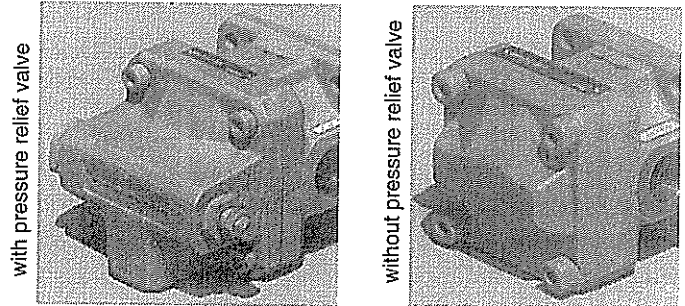

Functional symbols

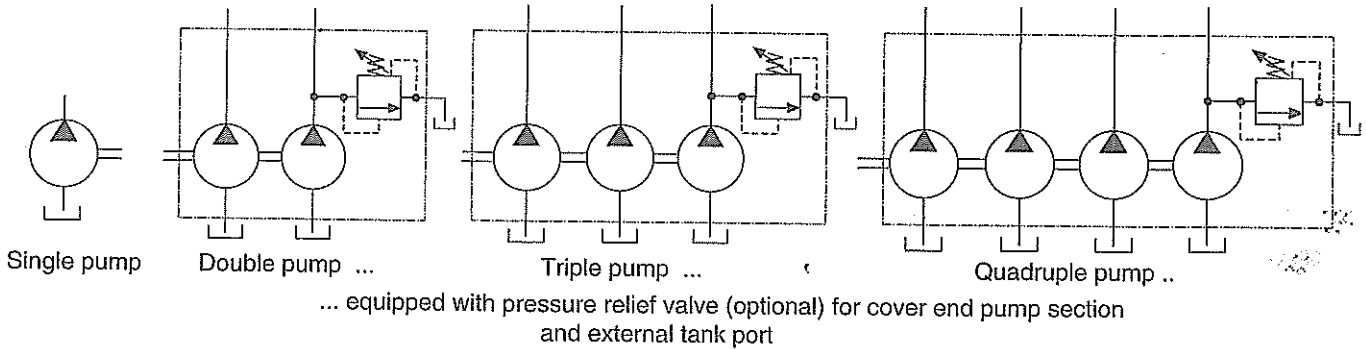

Cross section

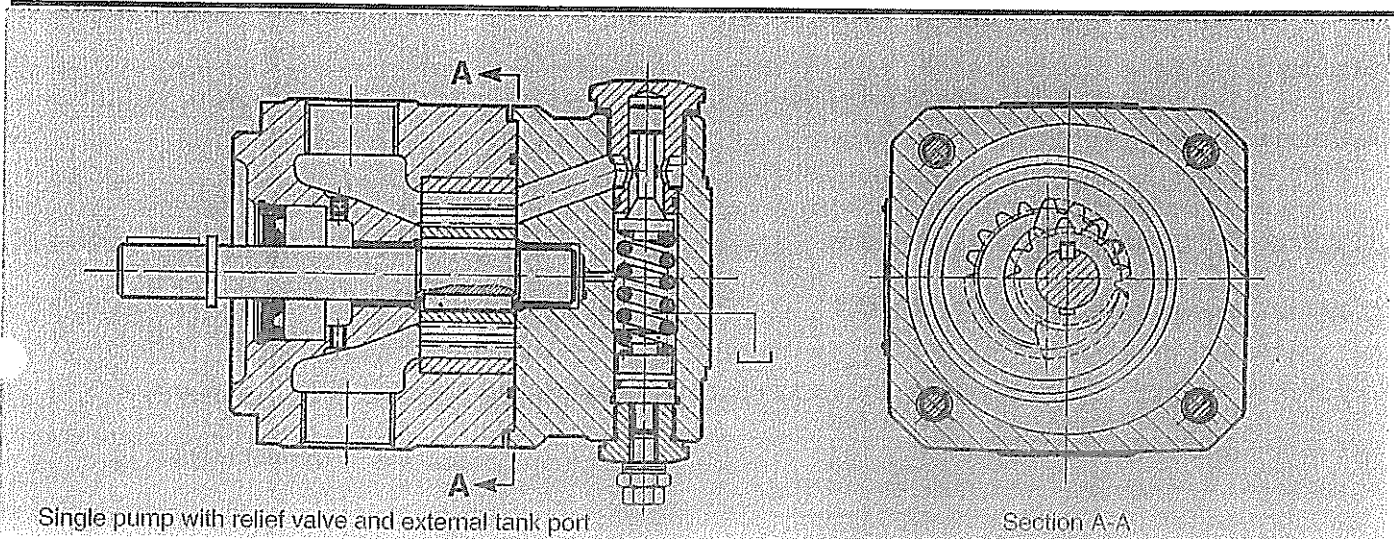

① **Seals for phosphate ester fluids**

Omit if not required.

② **Mounting flange**

P = 4-hole square mounting flange to ISO 3019/2, standard for frame size **A3**, so always fill in for **A3**
w/o = SAE 2-hole oval mounting flange (ISO 3019/1)
 Option for frame sizes by code **A1** and **A2** only.

③ **Frame size**

A1 = Displacement 1.76 cm³ ... 4.40 cm³
A2 = Displacement 6.90 cm³ ... 17.30 cm³
A3 = Displacement 25.50 cm³ ... 63.60 cm³

④,⑤,⑥ **Displacement of single pump or pump section**

For multiple pumps of only one frame size the displacements increase from shaft end to cover end

④	⑤	⑥
1 = 1.76 cm ³	6 = 6.90 cm ³	25 = 25.50 cm ³
2 = 2.75 cm ³	10 = 11.00 cm ³	40 = 40.80 cm ³
4 = 4.40 cm ³	16 = 17.30 cm ³	63 = 63.60 cm ³

⑦ **Mounting flange**

A = SAE 'A' size 2-hole oval mounting flange (ISO 3019/1). For frame sizes **A1** and **A2** only.
 Omit for 4-hole metric square flanges to ISO 3019/2, for all GPA models.

⑧ **Front bearing arrangement**

E = for plain bearing for direct drives
F = roller and plain bearings, for indirect drives.
 (always fill in for frame size **A1** SAE "A" SAE 2-hole oval mounting flange (ISO 3019/1))

⑨ **Integral adjustable relief valve**

(Omit if not required).

	H = 5 ... 25 bar
Adjustment range	K = 5 ... 60 bar
	M = 5 ... 100 bar

⑩ **Relief valve discharge**

(Omit if no relief valve is specified).

- 1 = External discharge
- 2 = Internal discharge

⑪ **Design number**

30 = Series 30. Subject to change. Installation dimensions unchanged for design numbers 30 to 39.

⑫ **Shaft rotation, viewed at drive shaft end**

L = for counter-clockwise rotation
R = for clockwise rotation

⑬ **Special features suffix**

GE330 = Fluid sealing between sections of a multiple pump. Omit if not required.

Model keys for pump variations by both number and frame sizes of pump sections. The keys have to be completed by displacement code(s) and from key ⑦ on according to requirements.

Single pumps

- ① - **G**② **A1-④** ↗
- ① - **G**② **A2-⑤** ↗
- ① - **GP** **A3-⑥** ↗

Double pumps

- ① - **G**② **A1-④ -④** ↗
- ① - **G**② **A2-⑤ -⑤** ↗
- ① - **G**② **A2-⑤ — A1-④** ↗
- ① - **GP** **A3-⑥ -⑥** ↗
- ① - **GP** **A3-⑥ — A2-⑤** ↗
- ① - **GP** **A3-⑥ — A1-④** ↗

Triple pumps

- ① - **G**② **A1-④ -④ -④** ↗
- ① - **G**② **A2-⑤ -⑤ -⑤** ↗
- ① - **G**② **A2-⑤ -⑤ — A1-④** ↗
- ① - **G**② **A2-⑤ — A1-④ -④** ↗
- ① - **GP** **A3-⑥ -⑥ -⑥** ↗
- ① - **GP** **A3-⑥ -⑥ — A2-⑤** ↗
- ① - **GP** **A3-⑥ — A2-⑤ -⑤** ↗
- ① - **GP** **A3-⑥ -⑥ — A1-④** ↗
- ① - **GP** **A3-⑥ — A1-④ -④** ↗
- ① - **GP** **A3-⑥ — A2-⑤ — A1-④** ↗

Quadruple pumps

- ① - **G**② **A1-④ -④ -④ -④** ↗
- ① - **G**② **A2-⑤ -⑤ -⑤ -⑤** ↗
- ① - **G**② **A2-⑤ -⑤ -⑤ — A1-④** ↗
- ① - **G**② **A2-⑤ -⑤ — A1-④ -④** ↗
- ① - **G**② **A2-⑤ — A1-④ -④ -④** ↗
- ① - **GP** **A3-⑥ -⑥ -⑥ -⑥** ↗
- ① - **GP** **A3-⑥ -⑥ -⑥ — A2-⑤** ↗
- ① - **GP** **A3-⑥ -⑥ — A2-⑤ -⑤** ↗
- ① - **GP** **A3-⑥ — A2-⑤ -⑤ -⑤** ↗
- ① - **GP** **A3-⑥ -⑥ -⑥ — A1-④** ↗
- ① - **GP** **A3-⑥ -⑥ — A1-④ -④** ↗
- ① - **GP** **A3-⑥ — A1-④ -④ -④** ↗
- ① - **GP** **A3-⑥ -⑥ — A2-⑤ — A1-④** ↗
- ① - **GP** **A3-⑥ — A2-⑤ -⑤ — A1-④** ↗
- ① - **GP** **A3-⑥ — A2-⑤ — A1-④ -④** ↗

↗ model codes have to be completed by

— ⑦ - ⑧ - ⑨ - ⑩ - 30 - ⑫ - ⑬

Operating data

Pressure limits

Inlet ports	min. continuous	- 0.25 bar
	min. intermittent	- 0.40 bar
	maximum	+ 2.00 bar
Outlet ports, maxi.:	with antiwear hydraulic oils	100 bar
	with burner fuel oils	50 bar
	with other fluids	consult JSB

Shaft speed limits, max. speed (rev/min) ▲

Frame size	Operating pressure	
	20 bar	100 bar
G(P)A 1	4000	3000
G(P)A 2	3500	3000
G P A 3	2300	2000

▲ For burner fuel oils max. speed for all sizes
n = 1800 rev/min

Shaft speed limits, min. speed (rev/min)

Frame size	Oil viscosity [cSt]	Operating pressure		
		60 bar	80 bar	10 bar
G(P)A 1	14.5	500	600	800
	9.0	600	800	
	7.5	800		
G(P)A 2	14.5	< 500 *	500	600
	9.0	500	600	
	7.5	600		
G P A 3	14.5	< 500 *	< 500 *	500
	9.0	< 500 *	500	
	7.5			

* For specific applications, consult **JSB** representative

Performance data

Typical at 1500 rev/min with oil at 40 cSt and at 38°C

Pump size	7 bar		25 bar		50 bar		70 bar		100 bar	
	L/min	KW	L/min	KW	L/min	KW	L/min	KW	L/min	KW
G(*)A1-1	2,6	0,1	2,5	0,15	2,4	0,3	2,3	0,4	2,1	0,6
G(P)A1-2	4,1	0,1	4,0	0,25	3,9	0,5	3,8	0,7	3,6	0,9
G(P)A1-4	6,6	0,15	6,4	0,40	6,2	0,7	6,0	0,9	5,7	1,3
G(P)A2-6	10,3	0,25	10,0	0,6	9,7	1,1	9,3	1,4	8,9	2,0
G(P)A2-10	16,5	0,4	16,1	0,9	15,7	1,6	15,3	2,3	14,8	3,2
G(P)A2-16	25,9	0,6	25,5	1,5	25,0	2,6	24,5	3,7	23,8	5,1
GPA3-25	36,4	0,85	35,2	2,2	34,0	3,8	32,7	5,1	31,3	7,1
GPA3-40	60,4	1,4	58,7	3,0	57,3	5,5	55,9	7,5	54,3	10,8
GPA3-63	94,3	2,2	92,8	4,4	91,2	8,8	89,5	12,0	87,7	16,8

Temperature limits

Antiwear hydraulic oil 0 to 68 °C
Water glycol 0 to 60 °C

For phosphate esters consult manufacturer and **JSB** where limits are outside those for hydraulic oil. Also consult **JSB** before using burner fuel oils. Whatever the actual temperature range is, ensure that viscosities stay within the limits specified in the 'Hydraulic fluids' section.

Hydraulic fluids.

All pumps can be used with antiwear hydraulic oils or water glycols. (continued right column above).

Burner fuels to BS.2869 Class D or equivalent can be pumped but will necessitate lower max pressures and speeds, consult **JSB**.

Add prefix 'F3' to model designation when phosphate ester (alkyl based types not permitted) or chlorinated hydrocarbons are to be used.

The extreme operating viscosity is from 1000 to 16 cSt but the recommended running range for hydraulic fluids is from 45 to 30 cSt.

However, for burner fuels the range is 5.5 to 1.5 cSt.

Noise levels

Typical levels when operating at 100 bar with oil at 28 cSt and 65°C. Inlet pressure minus 0.16 bar.

Measured in accordance with ISO 4412

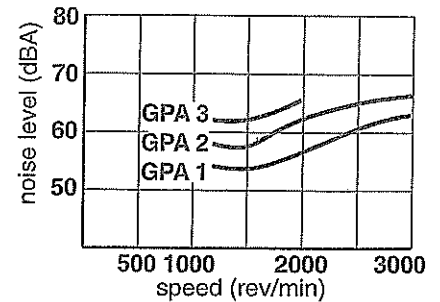

Filtration requirements: 25 µm absolute, or finer.

Drive recommendations

Direction of rotation

Clockwise or counter-clockwise (viewed at shaft end). To order see also 'Model code' and 'Installation dimensions' sections.

Load and torque limits

For direct drives, shafts for all single pumps and common frame size double pumps are designed to operate at rated pressure.

Double and triple pumps must be used within the following limits where:

p_1, p_2, p_3 & p_4 = Max. pressures [bar] of individual sections (referenced from the shaft end) for the application.

V_1, V_2, V_3 & V_4 = Displacements (cm³) of the same sections.

$$\text{Shaft load}^* = (p_1 V_1) + (p_2 V_2) + (p_3 V_3) + (p_4 V_4)$$

$$\text{Internal coupling load}^* = (p_2 V_2) + (p_3 V_3) + (p_4 V_4)$$

* according to number of pump sections and max. hydr. load

Frame size	Check	
	Shaft load	Internal coupling load
G(P)A 1	≤ 1,32 x 10 ⁹	≤ 0,88 x 10 ⁹
G(P)A 2	≤ 5,2 x 10 ⁹	≤ 3,5 x 10 ⁹
G P A 3	≤ 19,1 x 10 ⁹	≤ 13,0 x 10 ⁹

If axial loading is envisaged or a quadruple pump is required, consult your **JSB** representative.

For indirect drives use only pumps fitted with the heavy duty bearing option; see 'Model code' section. Check drive shaft torque limits as for direct drives above and that transverse and axial loads do not exceed the following limits:

Frame size	Maximum transverse force	Maximum transverse moment	Maximum axial force
G(P)A 1	440 N	15.8 Nm	300 N
G(P)A 2	820 N	41.0 Nm	600 N
G P A 3	1600 N	102.4 Nm	1000 N

GPA single pumps and common frame multiple pumps, with and without integral pressure relief valves

Single pumps

Key 4 x 4 x 20 - GPA1
 Key 6 x 6 x 32 - GPA2
 Key 8 x 7 x 50 - GPA3

Outlet port for clockwise rotation models. Inlet port for counter-clockwise rotation models

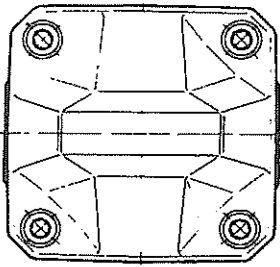

on request
 Circlip 12 x 1.0 - GPA1
 Circlip 20 x 1.2 - GPA2
 Circlip 30 x 1.5 - GPA3

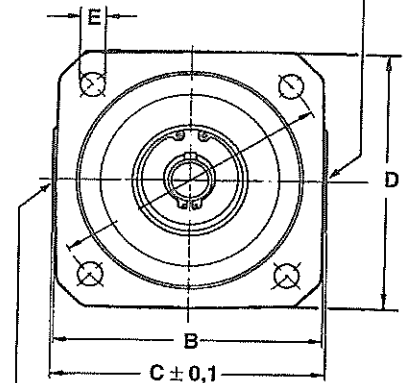
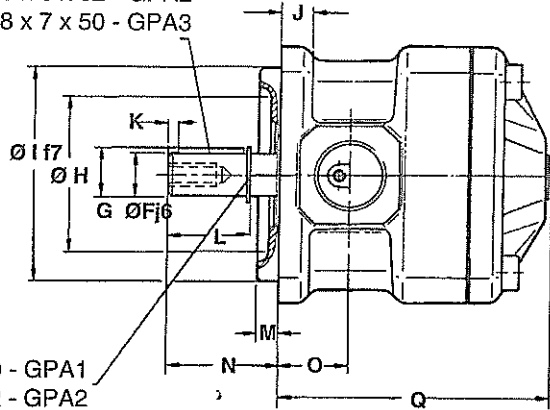

Inlet port for clockwise rotation models. Outlet port for counter-clockwise rotation models

Double pumps

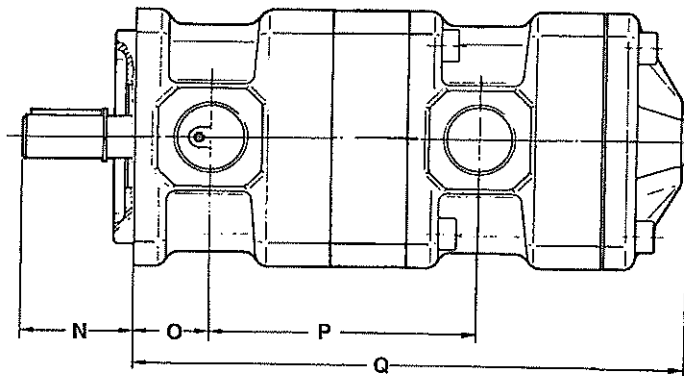

Shaft internal thread, all models

GPA	Thread size	Thread depth
1	M5	12
2	M8	18
3	M10	20

Port sizes (inlet and outlet the same size)

GPA1	G (BSP) 1/2"
GPA2	G (BSP) 1"
GPA3	G (BSP) 1 1/2"

Pumps with adjustable relief valves

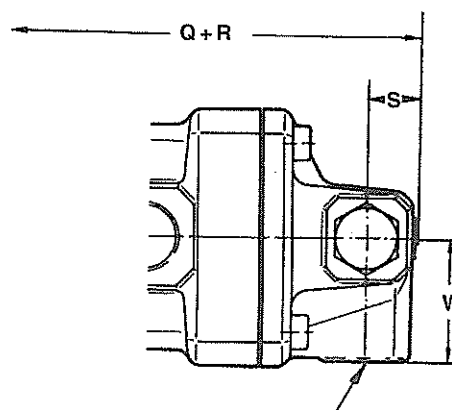
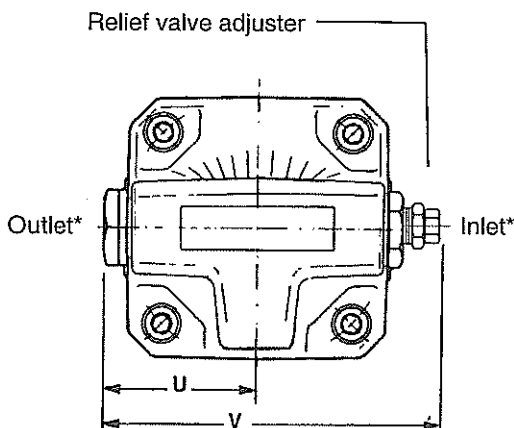

Cover as shown for clockwise rotation models*.
 Cover rotated through 180° for counter-clockwise models.
 * For counter-clockwise rotation the inlet and outlet port locations are interchanged.

Relief valve exhaust port

GPA1	G (BSP) 3/8"
GPA2	G (BSP) 3/4"
GPA3	G (BSP) 1 1/4"

Single and double pumps

Model	A	B	C	D	E	F	G	H	I	J	K	L	M	N	O	P	Q	Q+R	S	U	V	W
GPA1-1	85	80	82	80	9	12	13.5	44	63	10	3	25	7	34	25	-	77.5	98.5	17.0	45.5	115	36.5
GPA1-2	85	80	82	80	9	12	13.5	44	63	10	3	25	7	34	25	-	82.0	103.0	17.0	45.5	115	36.5
GPA1-4	85	80	82	80	9	12	13.5	44	63	10	3	25	7	34	25	-	89.5	110.5	17.0	45.5	115	36.5
GPAI-I-I	85	80	82	80	9	12	13.5	44	63	10	3	25	7	34	25	68.0	145.5	166.5	17.0	45.5	115	36.5
GPA1-1-2	85	80	82	80	9	12	13.5	44	63	10	3	25	7	34	25	68.0	150.0	171.0	17.0	45.5	115	36.5
GPA1-1-4	85	80	82	80	9	12	13.5	44	63	10	3	25	7	34	25	68.0	157.5	178.5	17.0	45.5	115	36.5
GPA1-2-2	85	80	82	80	9	12	13.5	44	63	10	3	25	7	34	25	72.5	154.5	175.5	17.0	45.5	115	36.5
GPA1-2-4	85	80	82	80	9	12	13.5	44	63	10	3	25	7	34	25	72.5	162.0	183.0	17.0	45.5	115	36.5
GPA1-4-4	85	80	82	80	9	12	13.5	44	63	10	3	25	7	34	25	80.0	169.5	190.5	17.0	45.5	115	36.5
GPA2-6	125	120	122	120	11	20	22.5	72	100	14	2	36	9	47	32	-	105.0	135.5	21.0	70.0	155	57.5
GPA2-10	125	120	122	120	11	20	22.5	72	100	14	2	36	9	47	32	-	112.5	143.0	21.0	70.0	155	57.5
GPA2-16	125	120	122	120	11	20	22.5	72	100	14	2	36	9	47	32	-	124.0	154.5	21.0	70.0	155	57.5
GPA2-6-6	125	120	122	120	11	20	22.5	72	100	14	2	36	9	47	32	88.0	193.0	223.5	21.0	70.0	155	57.5
GPA2-6-10	125	120	122	120	11	20	22.5	72	100	14	2	36	9	47	32	88.0	200.5	231.0	21.0	70.0	155	57.5
GPA2-6-16	125	120	122	120	11	20	22.5	72	100	14	2	36	9	47	32	88.0	205.0	236.5	21.0	70.0	155	57.5
GPA2-10-10	125	120	122	120	11	20	22.5	72	100	14	2	36	9	47	32	95.5	208.0	238.5	21.0	70.0	155	57.5
GPA2-10-16	125	120	122	120	11	20	22.5	72	100	14	2	36	9	47	32	95.5	219.5	250.0	21.0	70.0	155	57.5
GPA2-16-16	125	120	122	120	11	20	22.5	72	100	14	2	36	9	47	32	107.0	231.5	261.5	21.0	70.0	155	57.5
GPA3-25	160	150	152	150	14	30	33.0	-	125	17	3	58	10	69	40	-	134.5	183.0	31.5	90.0	202	72.5
GPA3-40	160	150	152	150	14	30	33.0	-	125	17	3	58	10	69	40	-	148.0	196.5	31.5	90.0	202	72.5
GPA3-63	160	150	152	150	14	30	33.0	-	125	17	3	58	10	69	40	-	167.5	216.0	31.5	90.0	202	72.5
GPA3-25-25	160	150	152	150	14	30	33.0	-	125	17	3	58	10	69	40	117.5	252.0	300.5	31.5	90.0	202	72.5
GPA3-25-40	160	150	152	150	14	30	33.0	-	125	17	3	58	10	69	40	117.5	265.5	314.0	31.5	90.0	202	72.5
GPA3-25-63	160	150	152	150	14	30	33.0	-	125	17	3	58	10	69	40	117.5	285.0	333.5	31.5	90.0	202	72.5
GPA3-40-40	160	150	152	150	14	30	33.0	-	125	17	3	58	10	69	40	131.0	279.0	327.0	31.5	90.0	202	72.5
GPA3-40-63	160	150	152	150	14	30	33.0	-	125	17	3	58	10	69	40	131.0	298.5	347.0	31.5	90.0	202	72.5
GPA3-63-63	160	150	152	150	14	30	33.0	-	125	17	3	58	10	69	40	150.5	318.0	366.5	31.5	90.0	202	72.5

Triple pumps and quadruple pumps of same frame sizes

As for double pumps above but dimensions Q and Q+R are each increased by the following amounts for each additional section, related to the second section.

Frame size	A1			A2			A3		
Displacement code	1	2	4	6	10	16	25	40	63
Enlargement [mm]	68	72.5	80	88	95.5	107	117.5	131.5	150.5

GPA double pumps 1 large + 1 small frame combinations

Models without relief valves

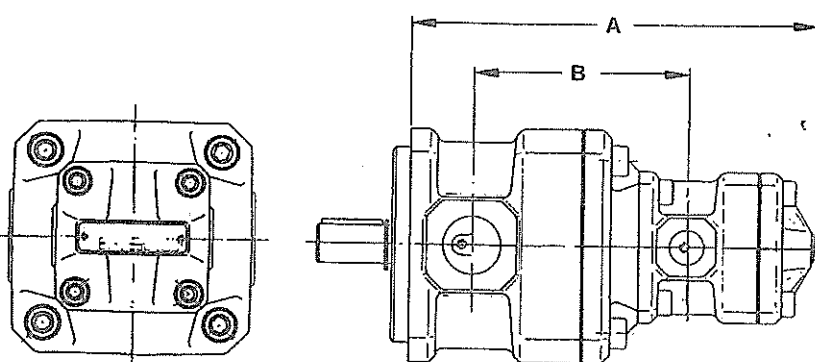

Models with relief valves

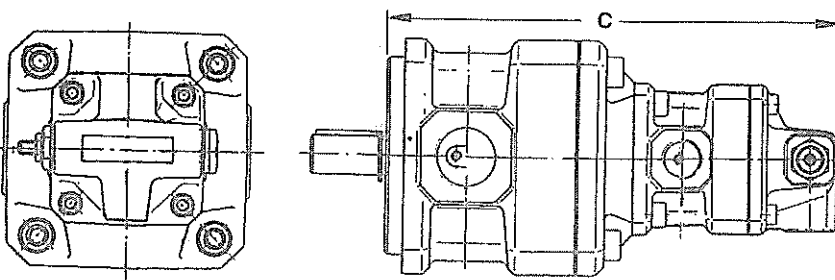

Further dimensions as on previous page and above

Model	A	B	C
GPA2-6-A1-1	175.5	91.0	196.5
GPA2-6-A1-2	180.0	91.0	201.0
GPA2-6-A1-4	187.5	91.0	208.5
GPA2-10-A1-1	183.0	98.5	204.0
GPA2-10-A1-2	187.5	98.5	208.5
GPA2-10-A1-4	195.0	98.5	216.0
GPA2-16-A1-1	194.5	110.0	215.5
GPA2-16-A1-2	199.0	110.0	220.0
GPA2-16-A1-4	206.5	110.0	227.5
GPA3-25-A1-1	206.5	114.0	227.5
GPA3-25-A1-2	211.0	114.0	232.0
GPA3-25-A1-4	218.5	114.0	239.5
GPA3-40-A1-1	220.0	127.5	241.0
GPA3-40-A1-2	224.5	127.5	245.5
GPA3-40-A1-4	232.0	127.5	253.0
GPA3-63-A1-1	239.5	147.0	260.5
GPA3-63-A1-2	244.0	147.0	265.0
GPA3-63-A1-4	251.5	147.0	272.5
GPA3-25-A2-6	232.5	119.5	263.0
GPA3-25-A2-10	240.0	119.5	270.5
GPA3-25-A2-16	251.5	119.5	282.0
GPA3-40-A2-6	246.0	133.0	276.5
GPA3-40-A2-10	253.5	133.0	284.0
GPA3-40-A2-16	265.0	133.0	295.5
GPA3-63-A2-6	265.5	152.5	296.0
GPA3-63-A2-10	273.0	152.5	303.5
GPA3-63-A2-16	284.5	152.5	315.0

GPA triple pumps

1 large + 2 small frame combinations

Models without relief valves

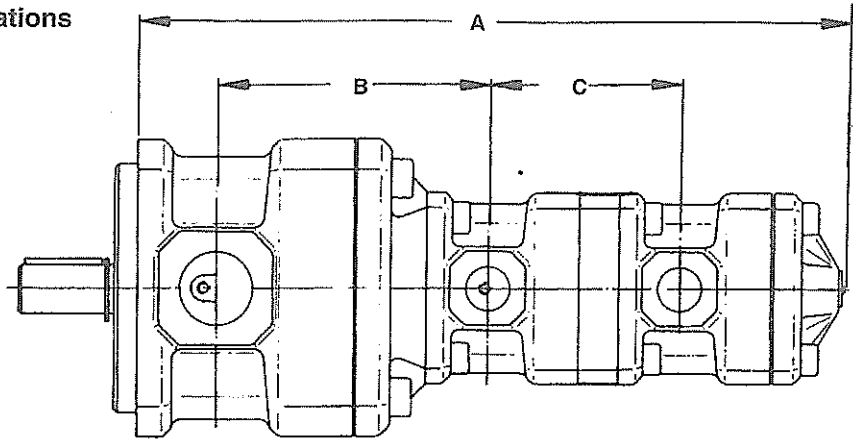
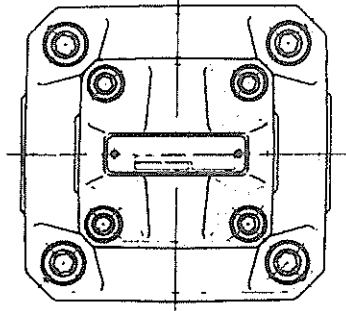

Models with relief valves

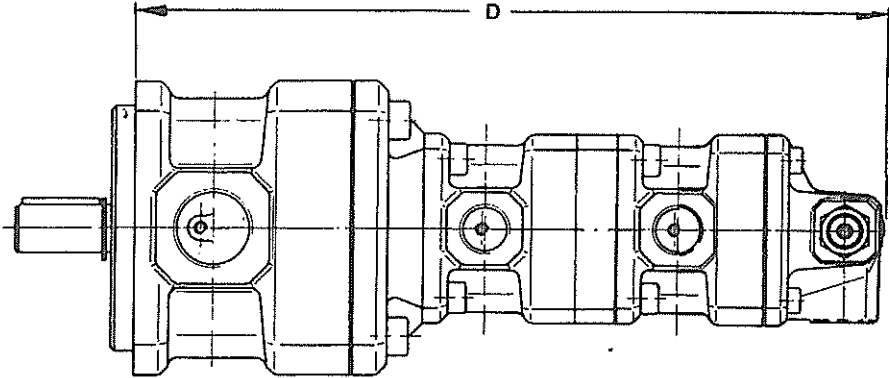
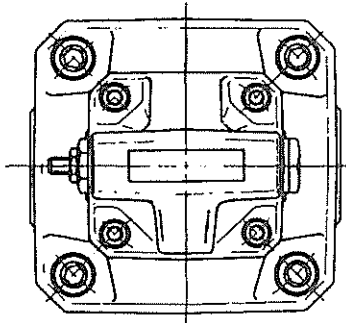

Model	A	B	C	D	Model	A	B	C	D	
GPA2-6-A1-1-1	243.5	91.0	68.0	264.5	GPA3-25-A1-2-2	283.5	114.0	72.5	304.5	Other dimensions as on the two previous pages
GPA2-10-A1-1-1	251.0	98.5	68.0	272.0	GPA3-40-A1-2-2	297.0	127.5	72.5	318.0	
GPA2-16-A1-1-1	262.5	110.0	68.0	283.5	GPA3-63-A1-2-2	316.5	147.0	72.5	337.5	
GPA2-6-A1-1-2	248.0	91.0	68.0	269.0	GPA3-25-A1-2-4	291.0	114.0	72.5	312.0	
GPA2-10-A1-1-2	255.5	98.5	68.0	276.5	GPA3-40-A1-2-4	304.5	127.5	72.5	325.5	
GPA2-16-A1-1-2	267.0	110.0	68.0	288.0	GPA3-63-A1-2-4	324.0	147.0	72.5	345.0	
GPA2-6-A1-1-4	255.5	91.0	68.0	276.5	GPA3-25-A1-4-4	298.5	114.0	80.0	319.5	
GPA2-10-A1-1-4	263.0	98.5	68.0	284.0	GPA3-40-A1-4-4	312.0	127.5	80.0	333.0	
GPA2-16-A1-1-4	274.5	110.0	68.0	295.5	GPA3-63-A1-4-4	331.5	147.0	80.0	352.5	
GPA2-6-A1-2-2	252.5	91.0	72.5	273.5	GPA3-25-A2-6-6	320.5	119.5	88.0	351.0	
GPA2-10-A1-2-2	260.0	98.5	72.5	281.0	GPA3-40-A2-6-6	334.0	133.0	88.0	364.5	
GPA2-16-A1-2-2	271.5	110.0	72.5	292.5	GPA3-63-A2-6-6	353.5	152.5	88.0	384.0	
GPA2-6-A1-2-4	260.0	91.0	72.5	281.0	GPA3-25-A2-6-10	328.0	119.5	88.0	358.5	
GPA2-10-A1-2-4	267.5	98.5	72.5	288.5	GPA3-40-A2-6-10	341.5	133.0	88.0	312.0	
GPA2-16-A1-2-4	279.0	110.0	72.5	300.0	GPA3-63-A2-6-10	361.0	152.5	88.0	391.5	
GPA2-6-A1-4-4	267.5	91.0	80.0	288.5	GPA3-25-A2-6-16	339.5	119.5	88.0	370.0	
GPA2-10-A1-4-4	275.0	98.5	80.0	296.0	GPA3-40-A2-6-16	353.0	133.0	88.0	383.5	
GPA2-16-A1-4-4	286.5	110.0	80.0	307.5	GPA3-63-A2-6-16	372.5	152.5	88.0	403.0	
GPA3-25-A1-1-1	274.5	114.0	68.0	295.5	GPA3-25-A2-10-10	335.5	119.5	95.5	366.0	
GPA3-40-A1-1-1	288.0	127.5	68.0	309.0	GPA3-40-A2-10-10	349.0	133.0	95.5	379.5	
GPA3-63-A1-1-1	307.5	147.0	68.0	328.5	GPA3-63-A2-10-10	368.5	152.5	95.5	399.0	
GPA3-25-A1-1-2	279.0	114.0	68.0	300.0	GPA3-25-A2-10-16	347.0	119.5	95.5	377.5	
GPA3-40-A1-1-2	292.5	127.5	68.0	313.5	GPA3-40-A2-10-16	360.5	133.0	95.5	391.0	
GPA3-63-A1-1-2	312.0	147.0	68.0	333.0	GPA3-63-A2-10-16	380.0	152.5	95.5	410.5	
GPA3-25-A1-1-4	286.5	114.0	68.0	307.5	GPA3-25-A2-16-16	358.5	119.5	107.0	389.0	
GPA3-40-A1-1-4	300.0	127.5	68.0	321.0	GPA3-40-A2-16-16	372.0	133.0	107.0	402.5	
GPA3-63-A1-1-4	319.5	147.0	68.0	340.5	GPA3-63-A2-16-16	391.5	152.5	107.0	422.0	

GPA triple pumps

2 large + 1 small frame combinations

Models without relief valves

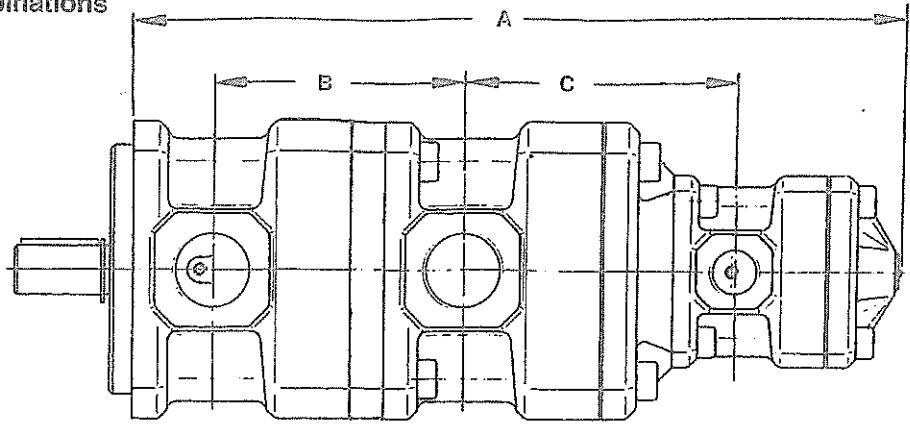
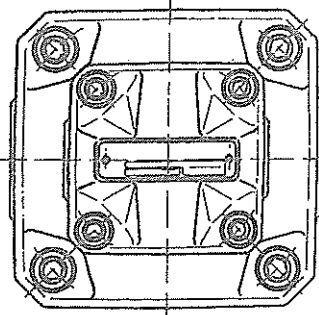

Models with relief valves

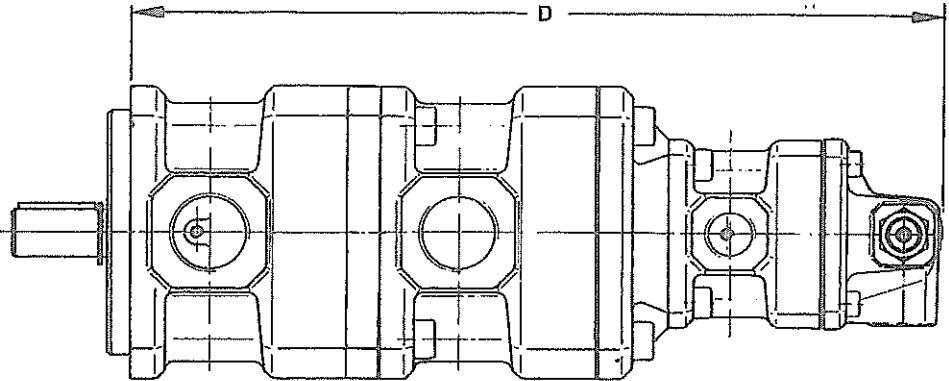
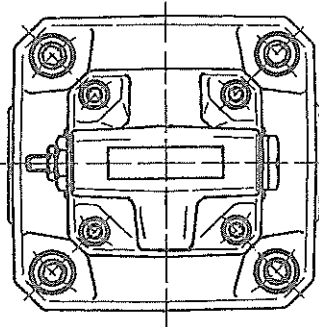

Model	A	B	C	D	Model	A	B	C	D	
GPA2-6-6-A1-1	263.5	88.0	91.0	284.5	GPA3-40-40-A1-1	351.0	131.0	127.5	372.0	Other dimensions as on the two previous pages
GPA2-6-6-A1-2	268.0	88.0	91.0	289.0	GPA3-40-40-A1-2	355.5	131.0	127.5	376.5	
GPA2-6-6-A1-4	275.5	88.0	91.0	296.5	GPA3-40-40-A1-4	363.0	131.0	127.5	384.0	
GPA2-6-10-A1-1	271.0	88.0	98.5	292.0	GPA3-40-63-A1-1	370.5	131.0	147.0	391.5	
GPA2-6-10-A1-2	275.5	88.0	98.5	296.5	GPA3-40-63-A1-2	375.0	131.0	147.0	396.0	
GPA2-6-10-A1-4	283.0	88.0	98.5	304.0	GPA3-40-63-A1-4	382.5	131.0	147.0	403.5	
GPA2-6-16-A1-1	282.5	88.0	110.0	303.5	GPA3-63-63-A1-1	390.0	150.5	147.0	411.0	
GPA2-6-16-A1-2	287.0	88.0	110.0	308.0	GPA3-63-63-A1-2	394.5	150.5	147.0	415.5	
GPA2-6-16-A1-4	294.5	88.0	110.0	315.5	GPA3-63-63-A1-4	402.0	150.5	147.0	423.0	
GPA2-10-10-A1-1	278.5	95.5	98.5	299.5	GPA3-25-25-A2-6	350.0	117.5	119.5	380.5	
GPA2-10-10-A1-2	283.0	95.5	98.5	304.0	GPA3-25-25-A2-10	357.5	117.5	119.5	388.0	
GPA2-10-10-A1-4	290.5	95.5	98.5	311.5	GPA3-25-25-A2-16	369.0	117.5	119.5	399.5	
GPA2-10-16-A1-1	290.0	95.5	110.0	311.0	GPA3-25-40-A2-6	363.5	117.5	133.0	394.0	
GPA2-10-16-A1-2	294.5	95.5	110.0	315.5	GPA3-25-40-A2-10	371.0	117.5	133.0	401.5	
GPA2-10-16-A1-4	302.0	95.5	110.0	323.0	GPA3-25-40-A2-16	382.5	117.5	133.0	413.0	
GPA2-16-16-A1-1	301.5	107.0	110.0	322.5	GPA3-25-63-A2-6	383.0	117.5	152.5	413.5	
GPA2-16-16-A1-2	306.0	107.0	110.0	327.0	GPA3-25-63-A2-10	390.5	117.5	152.5	421.0	
GPA2-16-16-A1-4	313.5	107.0	110.0	334.5	GPA3-25-63-A2-16	402.0	117.5	152.5	432.5	
GPA3-25-25-A1-1	324.0	117.5	114.0	345.0	GPA3-40-40-A2-6	377.0	131.0	133.0	407.5	
GPA3-25-25-A1-2	328.5	117.5	114.0	349.5	GPA3-40-40-A2-10	384.5	131.0	133.0	415.0	
GPA3-25-25-A1-4	336.0	117.5	114.0	357.0	GPA3-40-40-A2-16	396.0	131.0	133.0	426.5	
GPA3-25-40-A1-1	337.5	117.5	127.5	358.5	GPA3-40-63-A2-6	396.5	131.0	152.5	427.0	
GPA3-25-40-A1-2	342.0	117.5	127.5	363.0	GPA3-40-63-A2-10	404.0	131.0	152.5	434.5	
GPA3-25-40-A1-4	349.5	117.5	127.5	370.5	GPA3-40-63-A2-16	415.5	131.0	152.5	446.0	
GPA3-25-63-A1-1	357.0	117.5	147.0	378.0	GPA3-63-63-A2-6	416.0	150.5	152.5	446.5	
GPA3-25-63-A1-2	361.5	117.5	147.0	382.5	GPA3-63-63-A2-10	423.5	150.5	152.5	454.0	
GPA3-25-63-A1-4	369.0	117.5	147.0	390.0	GPA3-63-63-A2-16	435.0	150.5	152.5	465.5	

GPA triple pumps

Three frame size combinations

Pumps without relief valves

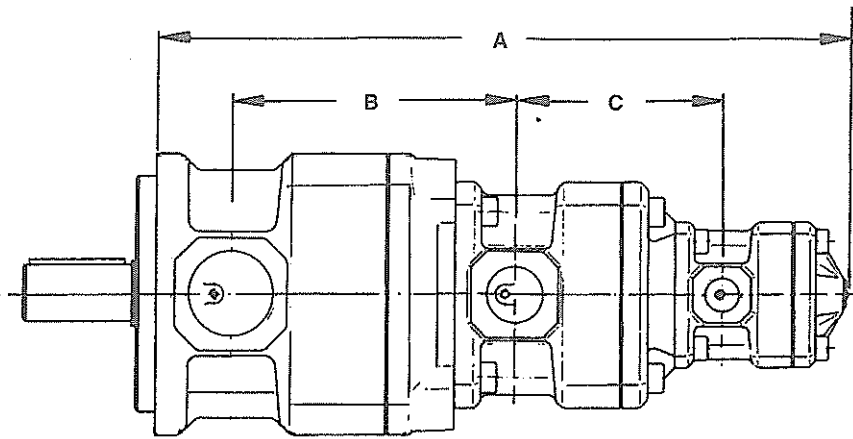
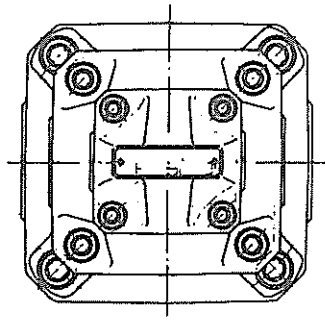

Pumps with relief valves

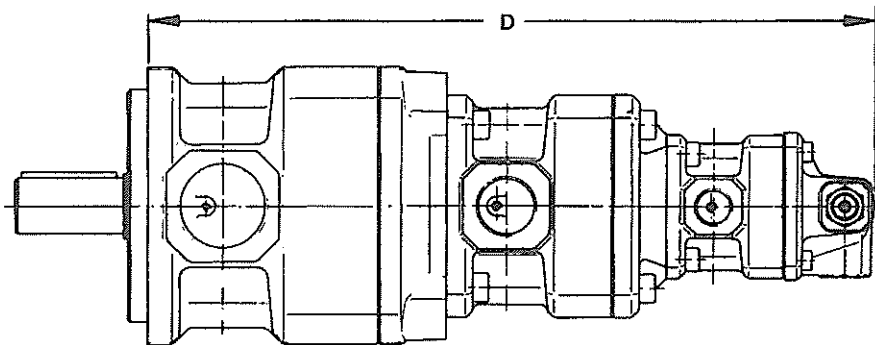
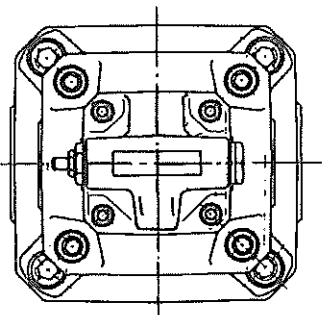

Model	A	B	C	D	Model	A	B	C	D
GPA3-25-A2-6-A1-1	303.0	119.5	91.0	324.0	GPA3-25-A2-10-A1-4	322.5	119.5	98.5	343.5
GPA3-40-A2-6-A1-1	316.5	133.0	91.0	337.5	GPA3-40-A2-10-A1-4	336.0	133.0	98.5	357.0
GPA3-63-A2-6-A1-1	336.0	152.5	91.0	357.0	GPA3-63-A2-10-A1-4	355.5	152.5	98.5	376.5
GPA3-25-A2-6-A1-2	307.5	119.5	91.0	328.5	GPA3-25-A2-16-A1-1	322.0	119.5	110.0	343.0
GPA3-40-A2-6-A1-2	321.0	133.0	91.0	342.0	GPA3-40-A2-16-A1-1	335.5	133.0	110.0	356.5
GPA3-63-A2-6-A1-2	340.5	152.5	91.0	361.5	GPA3-63-A2-16-A1-1	355.5	152.5	110.0	376.5
GPA3-25-A2-6-A1-4	315.0	119.5	91.0	336.0	GPA3-25-A2-16-A1-2	326.5	119.5	110.0	347.5
GPA3-40-A2-6-A1-4	328.5	133.0	91.0	349.5	GPA3-40-A2-16-A1-2	340.0	133.0	110.0	361.0
GPA3-63-A2-6-A1-4	348.5	152.5	91.0	369.5	GPA3-63-A2-16-A1-2	359.5	152.5	110.0	380.5
GPA3-25-A2-10-A1-1	310.5	119.5	98.5	331.5	GPA3-25-A2-16-A1-4	334.0	119.5	110.0	355.0
GPA3-40-A2-10-A1-1	324.0	133.0	98.5	345.0	GPA3-40-A2-16-A1-4	347.5	133.0	110.0	368.5
GPA3-63-A2-10-A1-1	343.5	152.5	98.5	364.5	GPA3-63-A2-16-A1-4	367.0	152.5	110.0	388.0
GPA3-25-A2-10-A1-2	315.0	119.5	98.5	336.0					
GPA3-40-A2-10-A1-2	328.5	133.0	98.5	349.5					
GPA3-63-A2-10-A1-2	348.0	152.5	98.5	369.0					

Other dimensions as on the first two pages of this "Installation dimensions" section

GA1 and GA2 series pumps

Single and multiple models

Dimensions shown relate to single pumps and the shaft-end section of multiple pumps.

All other dimensions and options as for the GPA1 and GPA2 single pumps, on the first two pages of this

"Installation dimensions" section, and multiple pumps having GPA1 or GPA2 shaft-end sections, as on the first four pages of the section.

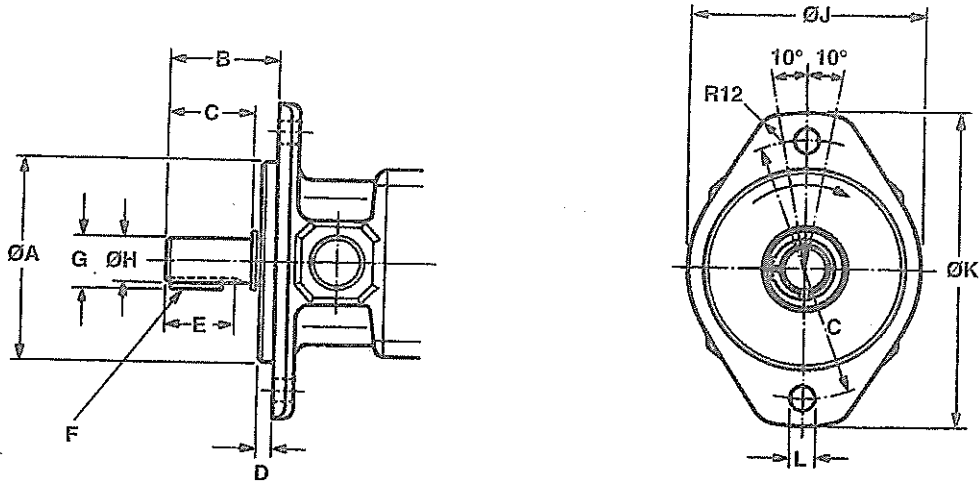

Model	A	B	C	D	E	F	G	H	J	K	L	M
GA1	82.55/82.50	44.5	36.6	6.4	28	□ 4.76 x 25	21.13/21.00	19.05/19.02	96	130	11.1	106.48/106.27
GA2	82.55/82.50	67.5	52.5	6.2	45	□ 4.76 x 41	21.13/21.00	19.05/19.02	96	130	11.1	106.48/106.27

Mass, approx.

Single pumps

Single pump 1st section	Without pressure relief valve	With pressure relief valve
G(P)A1-1	2.3	3.2
G(P)A1-2	2.5	3.4
G(P)A1-4	2.7	3.6
G(P)A2-6	7.5	9.3
G(P)A2-10	8.2	10.0
G(P)A2-16	9.4	11.2
GPA3-25	14.6	19.4
GPA3-40	16.6	21.4
GPA3-63	19.5	24.3

Multiple pumps

Sum of the shaft end (first) section from the previous table and additional section(s) from the following.

2nd, 3rd or 4th section	without pressure relief valve	with pressure relief valve
G(P)A1-*-1	2.4	3.3
G(P)A1-*-2	2.6	3.5
G(P)A1-*-4	2.8	3.7
G(P)A2-*-6	6.4	8.2
G(P)A2-*-10	7.1	8.9
G(P)A2-*-16	8.3	10.1
GPA3-*-25	13.3	18.1
GPA3-*-40	15.3	20.1
GPA3-*-63	18.2	23.0

Mounting attitude

Unrestricted

Some examples of variations for quadruple pumps (not to scale).

The multiple possibilities for both frame size and displacement result in a number of more than 1000 pump assemblies with different overall length and port distances (optional w/o pressure relief valve).

Overall length and port distance are not included here for the reason mentioned before. If these dimensions are required, please contact **JSB**.

Quadruple pump assembled from 4 equal frame sizes

A3 +A3 +A3 +A3

or A2 +A2 +A2 +A2

or A1 +A1 +A1 +A1

- without pressure relief valve

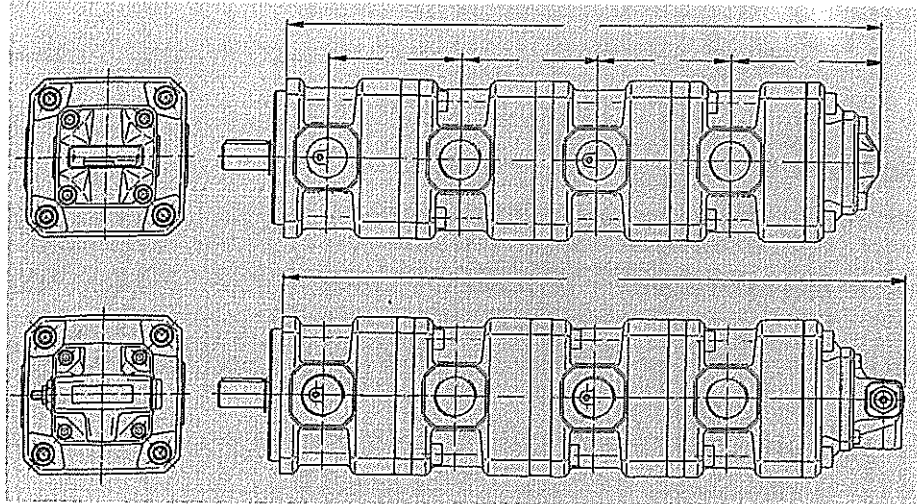

- with pressure relief valve

Quadruple pump assembled from 2 different frame sizes

as A3 +A3 +A3 +A2

or A2 +A2 +A2 +A1

shown without pressure relief valve option

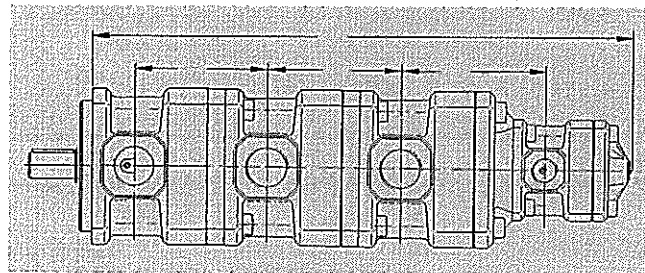

Quadruple pump assembled from 3 different frame sizes

as A3 +A2 +A2 +A1

shown without pressure relief valve option

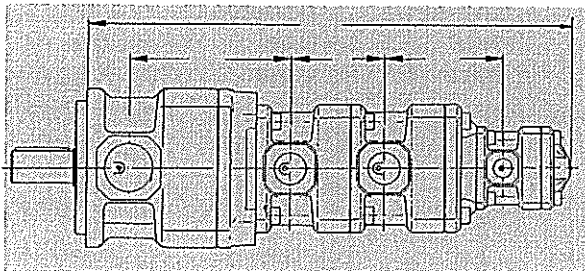

Quadruple pump assembled from 2 different frame sizes

as A3 +A2 +A2 +A2

or A2 +A1 +A1 +A1

shown without pressure relief valve option

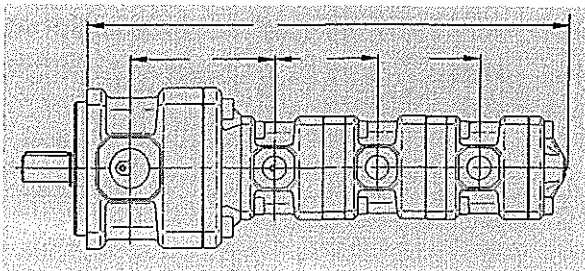

GARPHYTTAN GROUP

John S. Barnes GmbH
 Post Box 15 07 • D - 95014 Hof
 Seligenweg 12 • D - 95028 Hof
 Phone (0 92 81) 8 95 - 0
 Fax (0 92 81) 8 71 33

John S. Barnes Corp.
 Rockford, Illinois, 61104, USA
 2222 15th Street
 Phone (815) 398 - 4400
 Fax (815) 398 - 5977

JSB Hesselman AB
 S - 195 25 Märsta
 Phone (05 91) 2 88 50
 Fax (05 91) 2 88 60