

Italgroup[®]

HYDRAULIC MOTORS

ITALY



HC

Single displacement hydraulic motors – High Cavitation

The data specified into the catalogue are for product description purpose only and must not be interpreted as warranted characteristics in legal sense.
Italgroun S.r.l. reserves the right to implement modifications without notice.
All partial or total reproduction and copy without written authorization of Italgroun S.r.l. is strictly forbidden.

ITALGROUP HIGH CAVITATION MOTORS

HC SERIES

TECHNICAL CATALOGUE

INDEX

INTRODUCTION - HC SERIES	Pag. 2
MOTOR TECHNICAL DATA	" 3 - 4
HYDRAULIC FLUID RECOMMENDATIONS	" 6 - 7
INSTRUCTIONS AND ADVICES	" 8 - 9
CAVITATION AND FREEWHEELING	" 10
DRAIN RECOMMENDATIONS	" 11
FLUSHING FLOW	" 12
FLUSHING FLOW MEASUREMENT METHOD	" 12
SHAFT SEAL FEATURES	" 13 - 14
FORMULAS	" 15
CONVERSIONS	" 16
HC05	" 18 - 20
HC1	" 22 - 24
HC2	" 26 - 28
HC3	" 30 - 32
HC5	" 34 - 36
ORDERING INSTRUCTIONS	" 38
FLOW DISTRIBUTORS	" 40 - 43
TACHOMETERS	" 44
VALVES	" 46 - 54
CONTACT US	" 56
REACH US	" 56

The data specified into the catalogue are for product description purpose only and must not be interpreted as warranted characteristics in legal sense. ItalgrouP S.r.l. reserves the right to implement modifications without notice. All partial or total reproduction and copy without written authorization of ItalgrouP S.r.l. is strictly forbidden.



HC SERIES

- ▶ Cavitation resistant
- ▶ Freewheeling and high speed operation
- ▶ Continuous operation
- ▶ Compact design
- ▶ Higher mechanical efficiency, speed and power than standard IAM series

After many years of continuous development and research, Italgrou S.r.l. designed a new conception of hydraulic motor for extreme applications, like cavitation and freewheeling. Innovative design concepts and production technologies were on the basis of the project development. The result is a completely new motor with excellent performances in terms of cavitation resistance, high speed and freewheeling operation. Together with our new IAMD series and the well know IAC series this motor can cover the majority of the market requests.

MOTOR TECHNICAL DATA

Motor	Size	Displacement [cc]	Theoretical torque [Nm/bar]	Max cont. pressure [bar]	Max cont. speed [rpm]	Peak speed (**) [rpm]	Max cont. power (*) [kW]	Peak power (***) [kW]	Dry weight [kg]
HC05 40	05	40	0.62	250	1200	1400	16	25	30
HC05 60	05	60	0.97	250	1200	1400	25	35	30
HC05 75	05	74	1.20	250	1200	1400	32	50	30
HC05 90	05	91	1.40	250	1100	1300	32	50	30
HC05 110	05	115	1.84	250	850	1100	35	55	30
HC05 130	05	129	2.05	250	850	1100	35	55	30
HC05 150	05	151	2.40	250	850	1100	35	55	30
HC05 170	05	166	2.65	250	750	1000	35	55	30
HC05 200	05	191	3.04	250	750	1000	35	55	30
HC05 250	05	226	3.60	250	600	800	35	55	30
HC1 100	1	98	1.57	250	1100	1250	40	60	34
HC1 150	1	154	2.45	250	700	1000	40	60	34
HC1 175	1	173	2.74	250	700	1000	45	75	34
HC1 200	1	200	3.20	250	600	900	45	75	34
HC1 250	1	243	3.88	250	600	800	50	75	34
HC1 300	1	289	4.61	250	550	700	50	75	34
HC1 330	1	315	5.01	250	450	650	50	75	34
HC2 200	2	193	3.06	250	1200	1500	75	105	53
HC2 250	2	251	4.00	250	950	1150	75	105	53
HC2 300	2	305	4.84	250	800	950	75	105	53
HC2 350	2	348	5.52	250	650	800	75	105	53
HC2 400	2	424	6.76	250	600	800	75	105	53
HC2 500	2	493	7.84	250	520	700	75	105	53
HC2 600	2	566	9.00	250	480	650	75	105	53
HC2 650	2	624	9.92	250	440	620	75	105	53
HC3 350	3	352	5.60	250	640	800	85	130	92
HC3 400	3	426	6.78	250	600	800	85	130	92
HC3 500	3	486	7.73	250	500	700	85	130	92
HC3 600	3	595	9.47	250	450	600	85	130	92
HC3 700	3	689	10.98	250	420	600	85	130	92
HC3 800	3	792	12.60	250	400	550	85	130	92
HC3 900	3	872	13.90	250	360	525	85	130	92
HC3 1000	3	988	15.70	250	310	500	85	130	92

For all motors:

- Intermittent pressure: 320 bar
- Peak pressure: 350 bar

- (*) For motor operation with a continuous duty cycle at maximum continuous power the flushing is required.

- (**) Do not exceed peak power.

- (***) For motor operation at peak power flushing is usually required. For more information please contact our technical department.

The data specified into the catalogue are for product description purpose only and must not be interpreted as warranted characteristics in legal sense. Italgroup S.r.l. reserves the right to implement modifications without notice. All partial or total reproduction and copy without written authorization of Italgroup S.r.l. is strictly forbidden.

MOTOR TECHNICAL DATA

Motor	Size	Displacement	Theoretical torque	Max cont. pressure	Max cont. speed	Peak speed (**)	Max cont. power (*)	Peak power (***)	Dry weight
		[cc]	[Nm/bar]	[bar]	[rpm]	[rpm]	[kW]	[kW]	[kg]
HC5 800	5	808	12.6	250	350	470	100	150	178
HC5 1000	5	1040	16.2	250	320	470	100	150	178
HC5 1200	5	1190	18.5	250	320	430	100	150	178
HC5 1300	5	1340	20.9	250	320	430	100	150	178
HC5 1500	5	1464	22.8	250	300	380	100	150	178
HC5 1600	5	1635	25.4	250	280	350	100	150	178
HC5 1800	5	1816	28.3	250	280	350	100	150	178
HC5 2000	5	2010	31.3	250	220	280	100	150	178

For all motors:

- Intermittent pressure: 320 bar
- Peak pressure: 350 bar

- (*) For motor operation with a continuous duty cycle at maximum continuous power the flushing is required.
- (**) Do not exceed peak power.
- (***) For motor operation at peak power flushing is usually required. For more information please contact our technical department.

The data specified into the catalogue are for product description purpose only and must not be interpreted as warranted characteristics in legal sense. Italgroupp S.r.l. reserves the right to implement modifications without notice. All partial or total reproduction and copy without written authorization of Italgroupp S.r.l. is strictly forbidden.

The data specified into the catalogue are for product description purpose only and must not be interpreted as warranted characteristics in legal sense. Italgroupp S.r.l. reserves the right to implement modifications without notice. All partial or total reproduction and copy without written authorization of Italgroupp S.r.l. is strictly forbidden.

Fluid selection

In general, we recommend the use of hydraulic oils with minimum viscosity index of 95, with anti-wear additives (ISO HM and HV). Once normal working temperature is reached, the drain oil viscosity must be at least 44 cSt, preferably in the range from 50 to 80 cSt.

HE oils (ecological fluids) are allowed, but must be used with particular attention, because they can influence the motor seals compatibility, and can reduce motor performances and life. Please contact us in case of HE oils usage.

Optimal viscosity selection

Referring the first approximated selection to the room temperature, we advice the following:

Room temperature	Oil
-20°C/0°C	BP ENERGOL HLP – HM 22
-15°C/+5°C	BP ENERGOL HLP – HM 32
-8°C/+15°C	BP ENERGOL HLP – HM 46
0°C/+22°C	BP ENERGOL HLP – HM 68
+8°C/+30°C	BP ENERGOL HLP – HM 100
-20°C/+5°C	BP BARTRAN HV 32
-15°C/+22°C	BP BARTRAN HV 46
0°C/+30°C	BP BARTRAN HV 68

ATF (automatic transmission fluid) oils, SAE 10-20-30 W oils, multigrade motor oils (SAE 15 W 40, 10 W 40), universal oils, can also be used. Always fill the motor (please refer to the "DRAIN RECOMMENDATIONS" section) with the selected hydraulic fluid before motor start-up. During cold start-up avoid high-speed operation until the system reach the working temperature, in order to provide an adequate lubrication. Every 5-8 °C of increase respect to the optimal working temperature for the selected oil, the hydraulic fluid life decrease of about 40-50% (refer to "OXIDATION" section). Consequently, the motor lifetime will be affected by the working temperature increase respect to the optimal working temperature of the selected oil. The maximum continuous working temperature is 70 °C, the temperature must be measured from motor drain line. If the motor doesn't have a drain line, the temperature must be evaluated at the return line port.

Fire resistant oil limitations

	Max cont. Pressure [bar]	Max int. Pressure [bar]	Max Speed [rpm]
HFA, 5-95% oil-water	103	138	50%
HFB, 60-40% oil-water	138	172	100%
HFC, water-glycol	103	138	50%
HFD, ester phosphate	250	293	100%

Filtration

Hydraulic systems oil must always be filtered. The choice of filtration grade derives from needs of service life and money spent. In order to obtain stated service life it is important to follow our recommendations concerning filtration grade. When choosing the filter it is important to consider the amount of dirt particles that filter can absorb and still operate satisfactorily. For that reason we recommend filters showing when you need to substitute filtering cartridge.

- 25 µm filtration required in most applications
- 10 µm filtration in closed circuit applications

Oxidation

Hydraulic oil oxidizes with time of use and temperature. Oxidation causes changes in colour and smell, acidity increase or sludge formation in the tank. Oxidation rate increases rapidly at surface temperatures above 60°C, in these situations oil should be checked more often. The oxidation process increases the acidity of the fluid; the acidity is stated in terms of the "neutralization number". Oxidation is usually slow at the beginning and then it increases rapidly. A sharp increase (by a factor of 2 to 3) in neutralization number between inspections shows that oil has oxidized too much and should be replaced immediately.

Water content

Oil contamination by water can be detected by sampling from the bottom of the tank. Most hydraulic oils repel the water, which then collects at the bottom of the tank. This water must be drained off at regular intervals. Certain types of transmission oils and engine oils emulsify the water; this can be detected by coatings on filter cartridges or a change in the colour of the oil. In such cases, obtain your oil supplier advice.

Degree of contamination

Heavy contamination of the oil causes wear rising in hydraulic system components. Contamination causes must be immediately investigated and remedied.

Analysis

It is recommended oil being analyzed every 6 months. The analysis should cover viscosity, oxidation, water content, additives and contamination. Most oil suppliers are equipped to analyze oil state and to recommend appropriate action. Oil must be immediately replaced if the analysis shows that it is exhausted.

Installation

Hoses and piping must be clean and free from contamination.

No other special requirements are necessary.

- Motor can be mounted in any position
- In run-away conditions you must use counterbalance valves
- Consult factory for intermittent applications

Splined adaptors (sleeves) are available upon request.

Installation circuit

The choice of open or closed loop circuit will be determined by the application.

Open loop circuits are cheaper and simpler to install.

Closed loop circuit is a superior circuit and usually takes up less space. It also offers better control features.

Start up

Motor case and pistons must be completely filled with oil before starting.

Do not load motor to maximum working pressure instantly.

During cold start-up avoid high-speed operation until the system reach the working temperature.

Case Drain – Case Pressure

Connect the case drain directly to tank.

The case drain port on the motor must be located on the highest point of the installation to ensure that the motor will always be full of oil. The case drain pressure must not exceed 6 bar continuous pressure.

(See drain recommendations page for more details)

Important

When the motor is installed vertically with shaft pointing upwards, consult our Technical Department. If the motor is connected to high inertial loads, the hydraulic system must be designed to prevent peaks of pressure and cavitation.

Temperature

Maximum oil temperature must not exceed 70°C (Please refer to hydraulic fluid recommendations). Heat exchangers must be used with higher temperatures.

Viscosity

The motor works satisfactory in a range of 3°E to 10°E oil viscosity. Best performance is obtained at the highest viscosity. (Please refer to hydraulic fluid recommendations)

Back Pressure

Don't exceed 70 bar back pressure.

Minimum speed

Standard minimum speed is about 3 rpm (depending on motor displacement). In case of a reasonable back pressure the minimum speed might be reduced. If you need less speed please contact our technical department.

Flushing

The operating fluid viscosity must always be higher than a certain minimum value (see "fluid recommendation" section) in order to guarantee an optimal motor internal lubrication. When the working conditions cause the motor case overheating above a critical value, the motor flushing is required. Flushing consists in the introduction of fresh oil (taken from the hydraulic circuit) into the motor case. Oil must be taken from the return line to avoid internal motor damage (the continuous motor case pressure must be maximum 6 bar). Flushing is an important operation that can be very effective to improve motor lifetime with heavy duty working conditions and improve the motor mechanical efficiency.

The motor flushing, if the motor works in one direction only, can be easily performed connecting the motor return line to the lowest motor drain port. The highest motor drain port must be connected to the tank. For D75 and D90 flow distributors, the side 1/4" metallic plugs can be used for flushing circuit installation: in fact the plug (corresponding to the return line port) can be removed and the connection between motor low pressure port and motor case can be correctly realized.

If the motor axis is not horizontal and/or the motor works in bidirectional operation, please contact Italgroup technical department, that can assist you to advice how to perform the desired operation in the best way. Just for your reference, Italgroup can provide you flushing valves in order to perform an effective flushing circuit.

For more details on the above mentioned arguments and for any further information please contact our technical department.

Cavitation and freewheeling

In hydraulic special applications like for example drilling machines, mobile applications, cavitation may be present. Infact when the motor is forced to run at a certain speed that requires an oil flow that is not disposable from the pump, in a transitory or continuous situation, the oil pressure inside the motor pistons decrease and can cause many problems like tractive forces on connecting rods retaining rings, metallic erosion (due to the air/vapor bubbles that develop when the piston pressure is very low and explodes when pressure rise above the equilibrium vapor pressure) and overheating.

It's always better to avoid motor cavitation or at least reduce it during operation (installing for example proper valves and using well designed circuits) but when this event cannot be avoided HC series motors are a very good solution in order to guarantee the correct motor operation in a safe and efficient way. It's always good to take into consideration circuit modifications in order to avoid cavitation mainly because the other components that are present in the circuit can be more sensible to the problem than the HC motor, therefore the HC can have an efficiency loss due not to the motor characteristics but to a bad cavitation resistance of the other circuit components.

Pressurization circuit

Please notice that using an auxiliary pump or a properly designed oil accumulator, in many cases (through the low pressure pipe pressurization) cavitation can be avoided or in all cases much reduced.

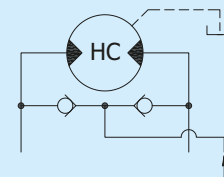

Auxiliary flow (from pump or accumulator)

Low-speed freewheeling circuit

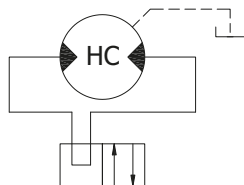

When the freewheeling requested speed is not high, the circuit shown on the left can be used. The speed for example can be controlled through a variable throttle valve. The main problem is that especially when throttle is acting, oil temperature can reach critical values.

High-speed freewheeling circuit

Realizing the freewheeling in this particular way the motor operates without oil into the pistons, so the energy consumption is always the same and independent by the motor speed. In addition this energy loss is very low. This is the most suitable circuit for high speed freewheeling operation.

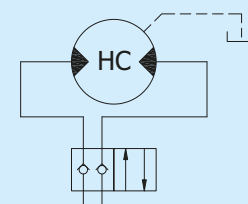

For more details on the above mentioned arguments and for any further information please contact our technical department.

Motor axis horizontal

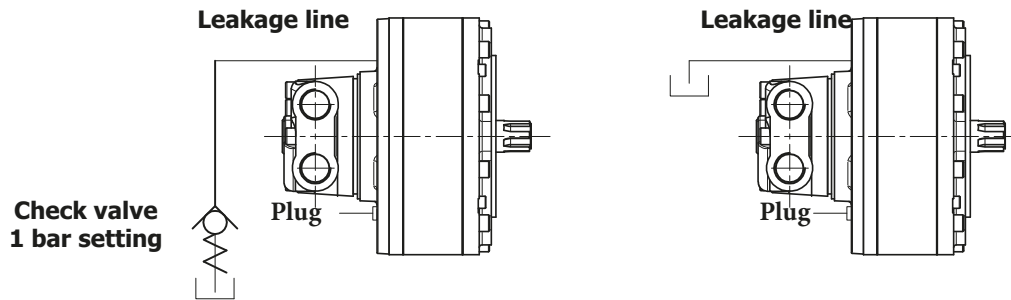

Motor axis vertical, shaft down

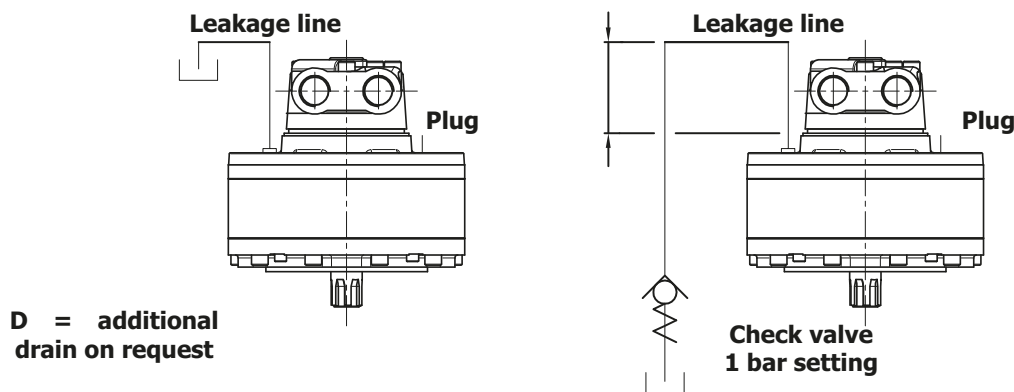

Motor axis vertical, shaft up

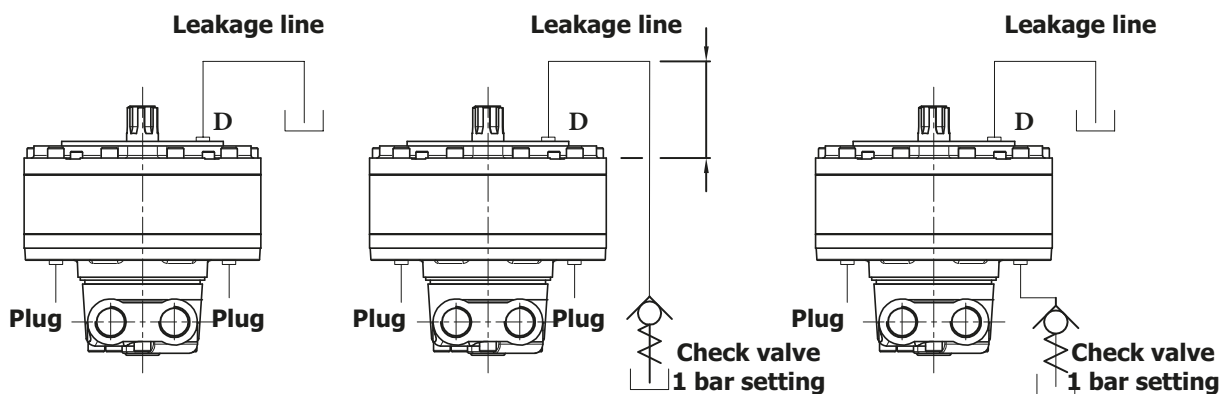

Leakage line connection

Always fill the motor with hydraulic fluid before start-up. Arrange piping in a way that the motor cannot drain off and cannot generate air bubbles into the motor case. Under certain conditions it may be necessary to arrange a check valve in order to help avoid the motor draining off. Always check carefully that the leakage line pressure doesn't overcome 6 bar pressure: therefore leakage lines must be shorter as possible and with a minimum flow resistance.

FLUSHING FLOW

Motor	Flushing flow [l/min]
HC05 40-60-75-90-110-130 HC1 100	5
HC05 150-170-200-250 HC1 150-175-200-250-300-330 HC2 200-250-300	6
HC2 350-400-500-600-630 HC3 400-500-600	8
HC3 700-800-900-1000	10
HC5 800-1000-1200 1500-1300-1500	10
H5 1600-1800-2000	15

Important note: the above value are approximated. The correct way to operate is the following: the flushing flow is adequate if during the motor operation the drain oil viscosity be at least 44 cSt, preferably in the range from 50 to 80 cSt.

FLUSHING FLOW MEASUREMENT METHOD

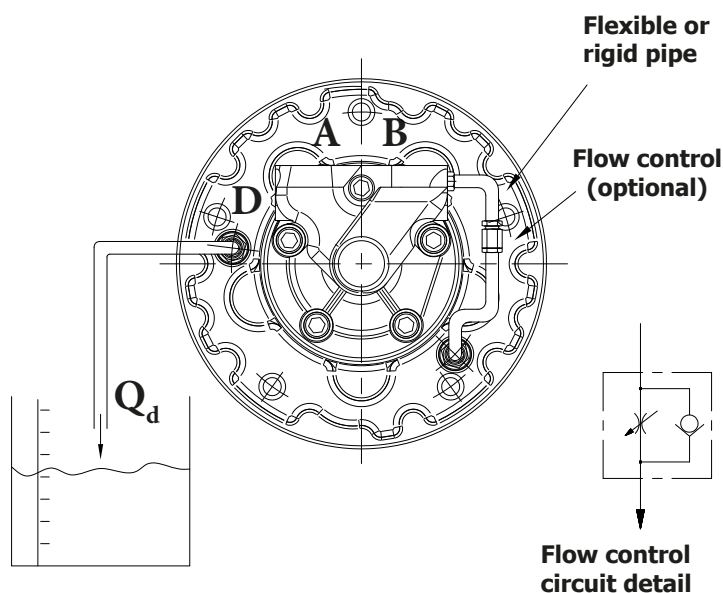

- Connect the tank drain pipe to a graduate plastic measuring container;
- measure the volume quantity of oil that flows into the container in one minute;
- the measured oil volume quantity is the flushing flow, Q_d .

A = high pressure port (inlet port)
B = low pressure port (outlet port)
D = drain port

Important: motorcase pressure must not exceed 6 bar continuous pressure

SHAFT SEAL FEATURES

Features

Type: x BABSL
Form: AS DIN 3760
Material: SIMRIT[®] 72 NBR 902
SIMRIT[®] 75 FKM 595

Material

SIMMERRING[®] radial shaft seal with rubber covered O.D., short, flexibility suspended, spring loaded sealing lip and additional dust lip: see Part B/SIMMERRING[®], sections 1.1 and 2.

Application

Sealing lip and O.D.:

- Acrylonitrile-butadiene rubber with 72 Shore A hardness (designation: SIMRIT[®] 72 NBR 902)
- Fluoro rubber with 75 Shore A hardness (designation: SIMRIT[®] 75 FKM 595)

Metal insert:

- Plain steel DIN 1624

Spring:

- Spring steel DIN 17223
-

Operating conditions

See Part B/ SIMMERRING[®], sections 2. 4.

Media: mineral oils, synthetic oils

Temperature:

- 40°C to +100°C (SIMRIT[®] 72 NBR 902)
- 40°C to +160°C (SIMRIT[®] 75 FKM 595)

Surface speed: up to 5 m/s

Working pressure: see diagram on next page, pressure is function of surface speed (i.e. of rotating speed and shaft diameter)

Housing and machining criteria

See Part B/ SIMMERRING®, sections 2.

Shaft:
 Tolerance: ISO h11
 Concentricity: IT 8
 Roughness: Ra=0.2-0.8 µm
 Rz=1-4 µm
 Rmax=6 µm
 Hardness: 45-60 HRC
 Roughness: non oriented;
 preferably by plunge grinding

Housing:
 Tolerance: ISO H8
 Roughness: Rmax<25 µm

Pressure diagram

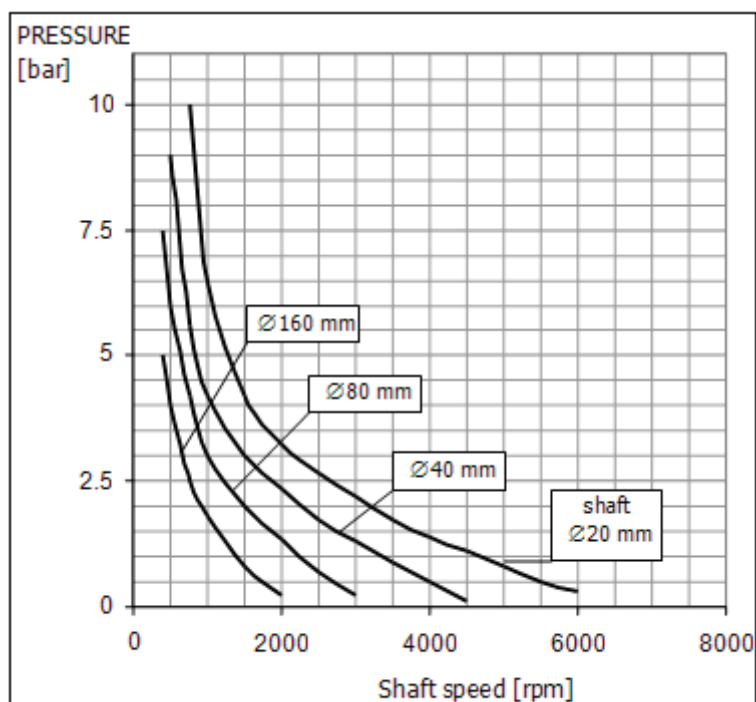

Diagram 1: Pressure Loading Limits

FORMULAS

LEGEND

T	Torque [Nm]
T _S	Specific torque [Nm/bar]
P ₁	Power [kW]
P ₂	Power [CV]
S	Speed [rpm]
V	Displacement [cc/Rev]
F	Flow [l/min]
P _r	Pressure [bar]

FORMULA

$$T = T_S * P_r = (V * P_r) / 62.8$$
$$P_1 = (T * S) / 9549$$
$$P_2 = (T * S) / 7023$$
$$S = (F * 1000) / V$$
$$V = (T * 62.8) / P_r$$
$$F = (V * S) / 1000$$

CONVERSIONS

LENGHT	1 m	= 39,3701 in
		= 3,2808 ft
		= 1,0936 yd
		= 1000 mm
	1 in	= 0,0833 ft
		= 25,4 mm
	1 ft	= 0,3048 m
		= 0,3333 yd
		= 12 in
	1 yd	= 0,9144 m
		= 3 ft
		= 36 in
	1 km	= 1000 m
		= 1093,6 yd
		= 0,6214 mile
	1 mile	= 1,609 km
		= 1760 yd
SPEED	1 m/s	= 3,6 km/h
		= 2,237 mph
		= 3,2808 ft/s
	1 km/h	= 0,2778 m/s
		= 0,6214 mph
		= 0,9113 ft/s
	1 mph	= 1,609 km/h
		= 0,447 m/s
		= 1,467 ft/s
	1 ft/s	= 0,3048 m/s
		= 1,0973 km/h
		= 0,6818 mph

MASS	1 kg	= 2,2046 lb
FORCE	1 N	= 0,102 kgf
		= 0,2248 lbf
	1 kgf	= 2,205 lbf
		= 9,806 N
	1 lbf	= 0,4536 kgf
		= 4,448 N
PRESSURE	1 bar	= 14,223 psi
		= 0,99 atm
		= 1,02 ata
		= 100000 Pa
		= 100 kPa
		= 0,1 MPa
	1 psi	= 0,0703 bar
FLOW	1 l/min	= 0,264 gpm
		= 1000 cc/Rev
	1 gpm	= 3,785 l/min
		= 3785 cc/min
	1 m ³ /s	= 60000 l/min
		= 15852 gpm

POWER	1 kW	= 1,341 HP
		= 1,3596 CV
	1 HP	= 0,7457 kW
		= 1,0139 CV
VOLUME	1 m ³	= 1000 l
	1 l	= 61,023 in ³
		= 0,264 galUS
	1 in ³	= 0,01639 l
		= 16,39 cm ³
		= 0,004326 galUS
	1 galUS	= 3,7879 l
		= 231,15 in ³
TORQUE	1 Nm	= 0,102 kgm
		= 0,7376 lbf ft
	1 kgm	= 9,806 Nm
		= 7,2325 lbf ft
	1 lbf ft	= 0,1383 kgm
		= 1,3558 Nm

The data specified into the catalogue are for product description purpose only and must not be interpreted as warranted characteristics in legal sense. ItalgrouP S.r.l. reserves the right to implement modifications without notice. All partial or total reproduction and copy without written authorization of ItalgrouP S.r.l. is strictly forbidden.

INSTALLATION DRAWING

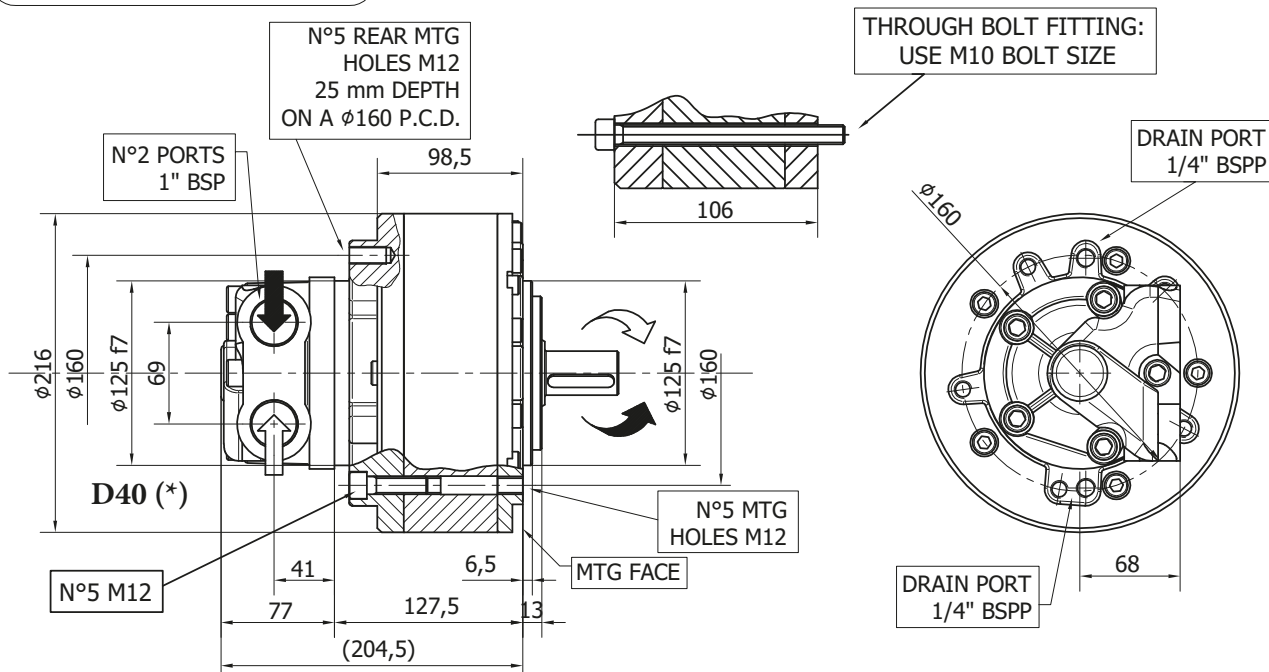

TECHNICAL DATA - HC 05

		40	60	75	90	110	130	150	175	200	250
DISPLACEMENT	[cc]	40	60	74	91	115	129	151	166	191	226
SPECIFIC TORQUE	[Nm/bar]	0.62	0.97	1.20	1.40	1.84	2.05	2.40	2.65	3.04	3.60
MAX. CONT. PRESSURE	[bar]	250	250	250	250	250	250	250	250	250	250
MAX. INT. PRESSURE	[bar]	320	320	320	320	320	320	320	320	320	320
PEAK PRESSURE	[bar]	350	350	350	350	350	350	350	350	350	350
MAX. CONT. SPEED	[rpm]	1200	1200	1200	1100	850	850	850	750	750	600
PEAK SPEED (***)	[rpm]	1400	1400	1400	1300	1100	1100	1100	1000	1000	800
MAX. CONT. POWER (****)	[kW]	16	25	32	32	35	35	35	35	35	35
PEAK POWER (*****)	[kW]	25	35	50	50	55	55	55	55	55	55
MAX. CASE PRESSURE	[bar]	6	6	6	6	6	6	6	6	6	6
DRY WEIGHT	[kg]	30	30	30	30	30	30	30	30	30	30
TEMPERATURE RANGE (**)	[°C]	-30÷70	-30÷70	-30÷70	-30÷70	-30÷70	-30÷70	-30÷70	-30÷70	-30÷70	-30÷70

- (*) The standard distributor (D40) is shown. Please refer to distributors section for different distributor interfaces.
- (**) Please refer to the hydraulic fluid recommendations.
- (***) Do not exceed peak power.
- (****) For motor operation with a continuous duty cycle at maximum continuous power the flushing is required.
- (*****) For motor operation at peak power flushing is usually required. For more information please contact our technical department.

The data specified into the catalogue are for product description purpose only and must not be interpreted as warranted characteristics in legal sense. Italgroup S.r.l. reserves the right to implement modifications without notice. All partial or total reproduction and copy without written authorization of Italgroup S.r.l. is strictly forbidden.

SHAFT CONFIGURATIONS

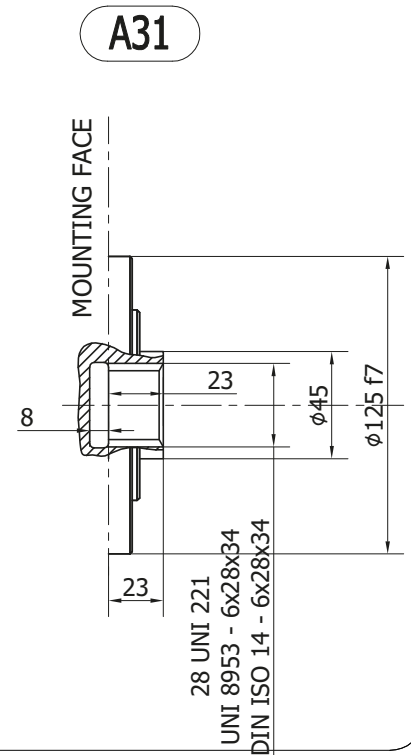
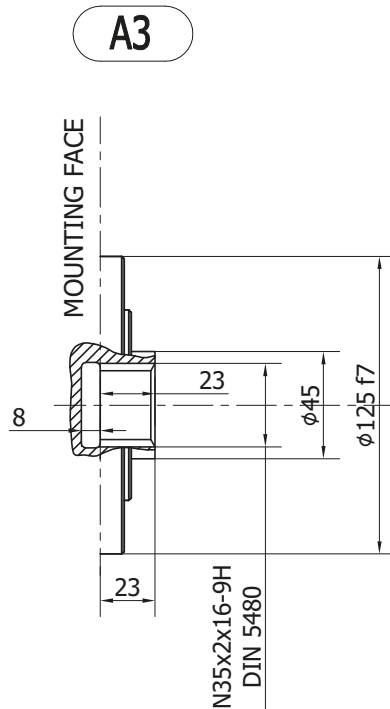
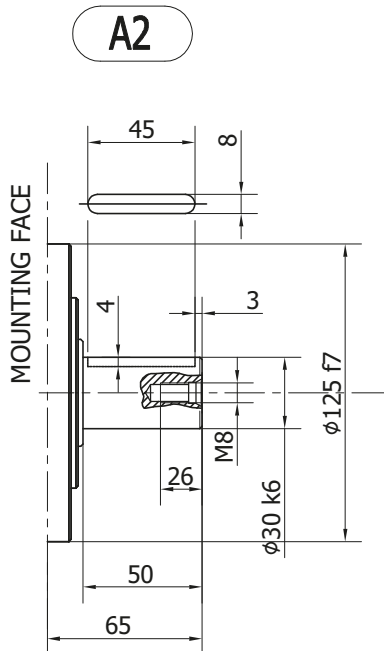
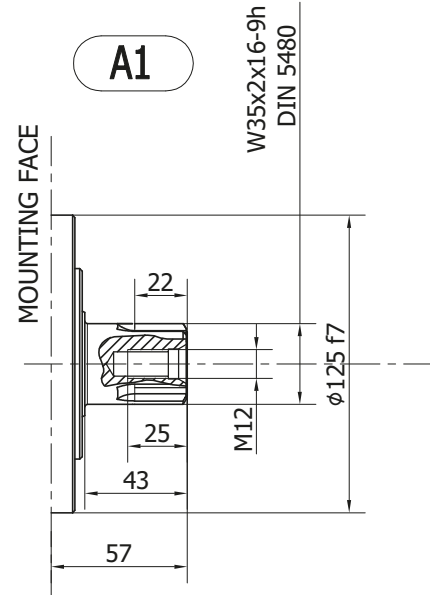
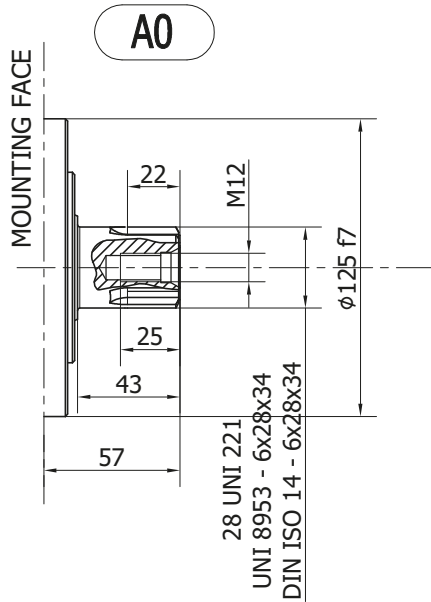

The data specified into the catalogue are for product description purpose only and must not be interpreted as warranted characteristics in legal sense. Italgrou S.r.l. reserves the right to implement modifications without notice. All partial or total reproduction and copy without written authorization of Italgrou S.r.l. is strictly forbidden.

SB14

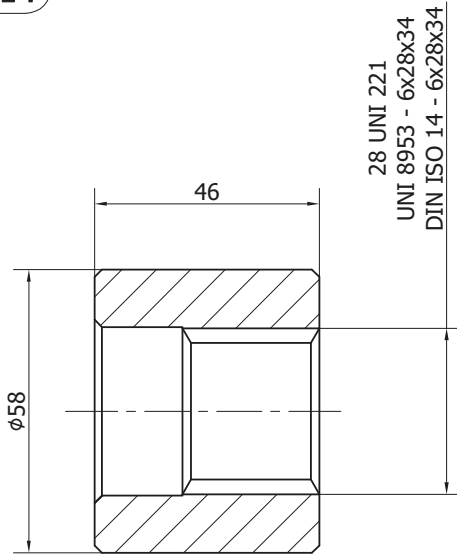

The data specified into the catalogue are for product description purpose only and must not be interpreted as warranted characteristics in legal sense. ItalgrouP S.r.l. reserves the right to implement modifications without notice. All partial or total reproduction and copy without written authorization of ItalgrouP S.r.l. is strictly forbidden.

INSTALLATION DRAWING

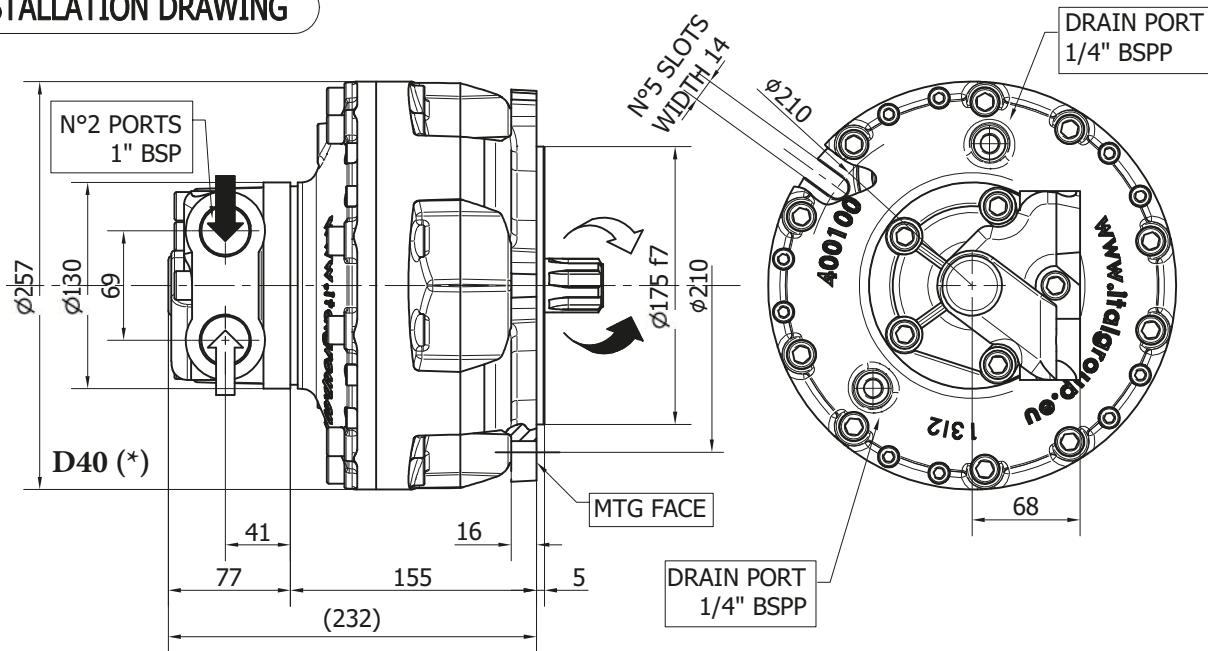

TECHNICAL DATA - HC 1

		100	150	175	200	250	300	330
DISPLACEMENT	[cc]	98	154	173	200	243	289	315
SPECIFIC TORQUE	[Nm/bar]	1.57	2.45	2.74	3.20	3.88	4.61	5.01
MAX. CONT. PRESSURE	[bar]	250	250	250	250	250	250	250
MAX. INT. PRESSURE	[bar]	320	320	320	320	320	320	320
PEAK PRESSURE	[bar]	350	350	350	350	350	350	350
MAX. CONT. SPEED	[rpm]	1100	700	700	600	600	550	450
PEAK SPEED (***)	[rpm]	1250	1000	1000	900	800	700	650
MAX. CONT. POWER (****)	[kW]	40	40	45	45	50	50	50
PEAK POWER (*****)	[kW]	60	60	75	75	75	75	75
MAX. CASE PRESSURE	[bar]	6	6	6	6	6	6	6
DRY WEIGHT	[kg]	34	34	34	34	34	34	34
TEMPERATURE RANGE (**)	[°C]	-30÷70	-30÷70	-30÷70	-30÷70	-30÷70	-30÷70	-30÷70

- (*) The standard distributor (D40) is shown. Please refer to distributors section for different distributor interfaces.
- (**) Please refer to the hydraulic fluid recommendations.
- (***) Do not exceed peak power.
- (****) For motor operation with a continuous duty cycle at maximum continuous power the flushing is required.
- (*****) For motor operation at peak power flushing is usually required. For more information please contact our technical department.

The data specified into the catalogue are for product description purpose only and must not be interpreted as warranted characteristics in legal sense. Italgrou S.r.l. reserves the right to implement modifications without notice. All partial or total reproduction and copy without written authorization of Italgrou S.r.l. is strictly forbidden.

SHAFT CONFIGURATIONS

A0

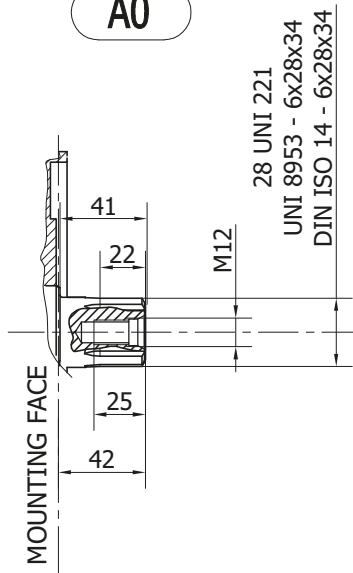

A1

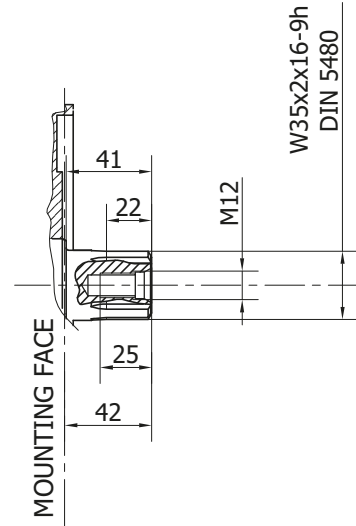

A2

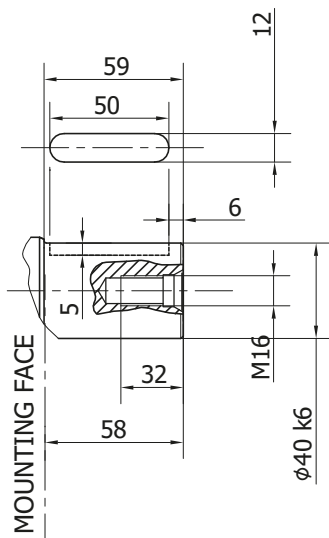

A3

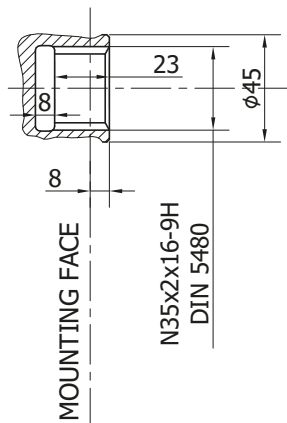

A31

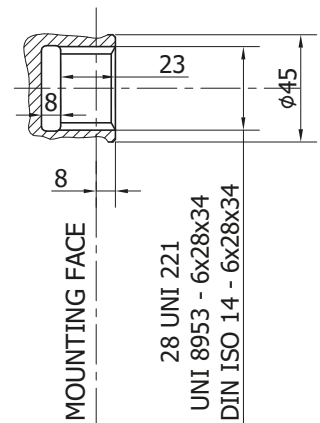

The data specified into the catalogue are for product description purpose only and must not be interpreted as warranted characteristics in legal sense. Italgroup S.r.l. reserves the right to implement modifications without notice. All partial or total reproduction and copy without written authorization of Italgroup S.r.l. is strictly forbidden.

SB14

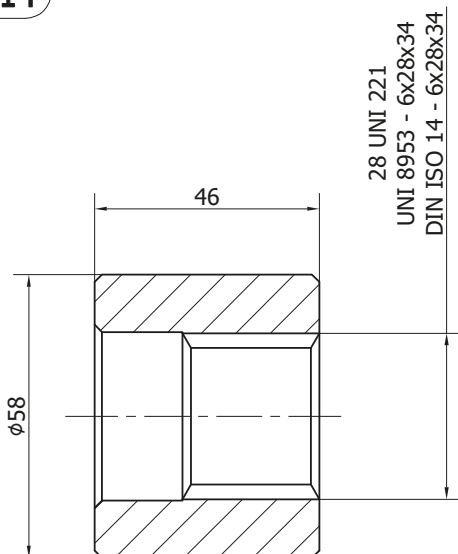

The data specified into the catalogue are for product description purpose only and must not be interpreted as warranted characteristics in legal sense. Italgroup S.r.l. reserves the right to implement modifications without notice. All partial or total reproduction and copy without written authorization of Italgroup S.r.l. is strictly forbidden.

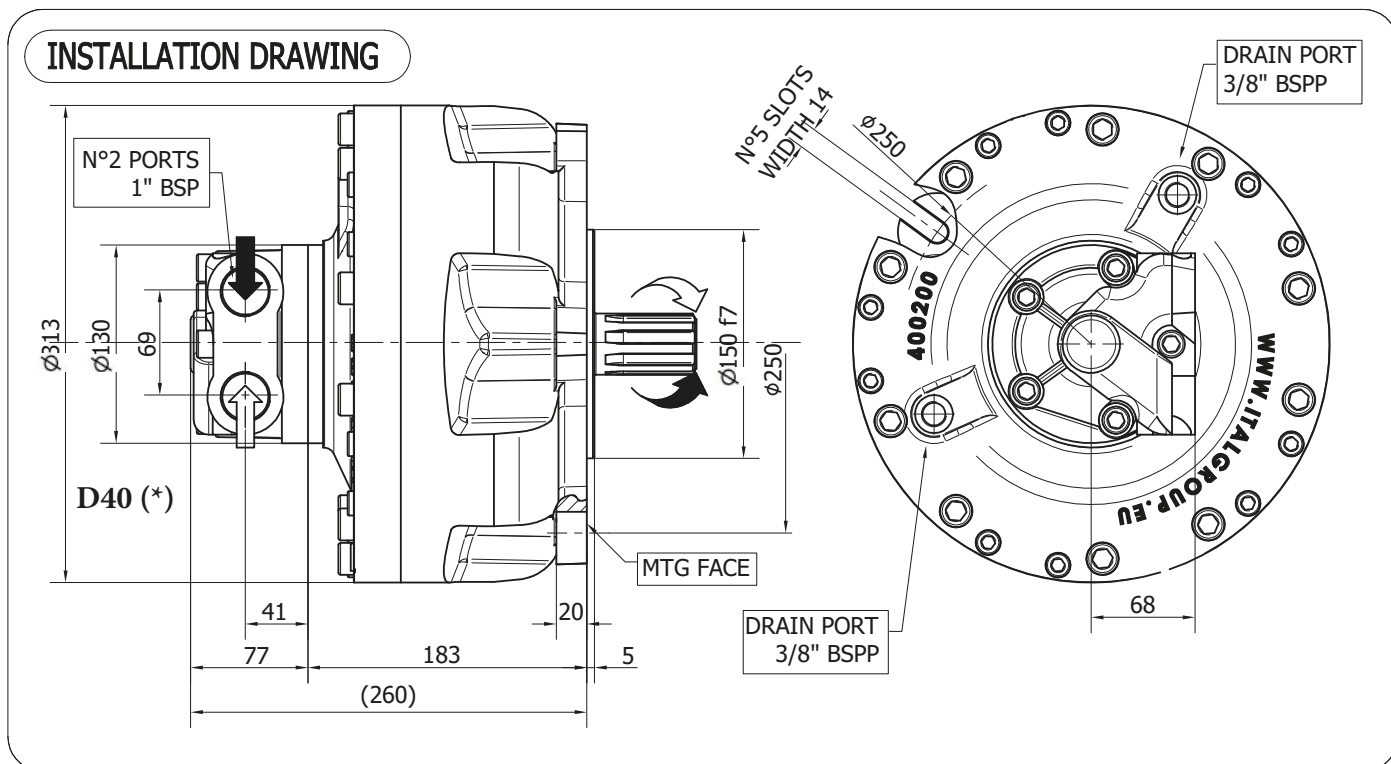

TECHNICAL DATA - HC 2

		200	250	300	350	400	500	600	650
DISPLACEMENT	[cc]	193	251	305	348	424	493	566	624
SPECIFIC TORQUE	[Nm/bar]	3.06	4.00	4.84	5.52	6.76	7.84	9.00	9.92
MAX. CONT. PRESSURE	[bar]	250	250	250	250	250	250	250	250
MAX. INT. PRESSURE	[bar]	320	320	320	320	320	320	320	320
PEAK PRESSURE	[bar]	350	350	350	350	350	350	350	350
MAX. CONT. SPEED	[rpm]	1200	950	800	650	600	520	480	440
PEAK SPEED (***)	[rpm]	1500	1150	950	800	800	700	650	620
MAX. CONT. POWER (****)	[kW]	75	75	75	75	75	75	75	75
PEAK POWER (*****)	[kW]	105	105	105	105	105	105	105	105
MAX. CASE PRESSURE	[bar]	6	6	6	6	6	6	6	6
DRY WEIGHT	[kg]	53	53	53	53	53	53	53	53
TEMPERATURE RANGE (**)	[°C]	-30÷70	-30÷70	-30÷70	-30÷70	-30÷70	-30÷70	-30÷70	-30÷70

- (*) The standard distributor (D40) is shown. Please refer to distributors section for different distributor interfaces.
- (**) Please refer to the hydraulic fluid recommendations.
- (***) Do not exceed peak power.
- (****) For motor operation with a continuous duty cycle at maximum continuous power the flushing is required.
- (*****) For motor operation at peak power flushing is usually required. For more information please contact our technical department.

The data specified into the catalogue are for product description purpose only and must not be interpreted as warranted characteristics in legal sense. Italgrou S.r.l. reserves the right to implement modifications without notice. All partial or total reproduction and copy without written authorization of Italgrou S.r.l. is strictly forbidden.

SHAFT CONFIGURATIONS

A0

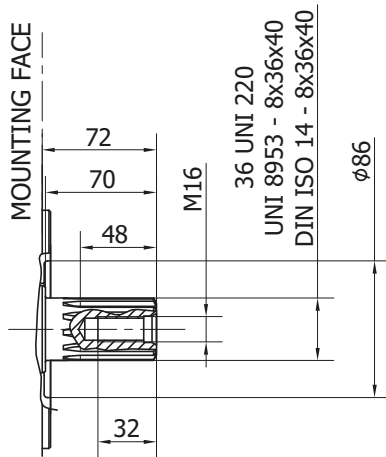

A1

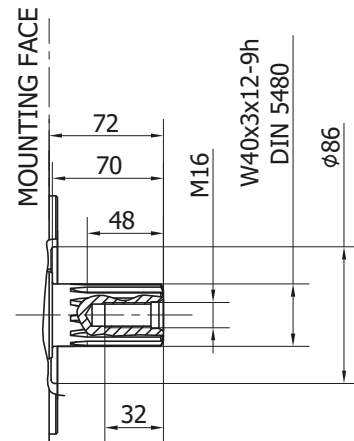

A2

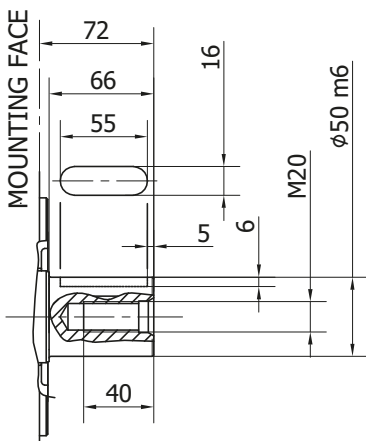

A3

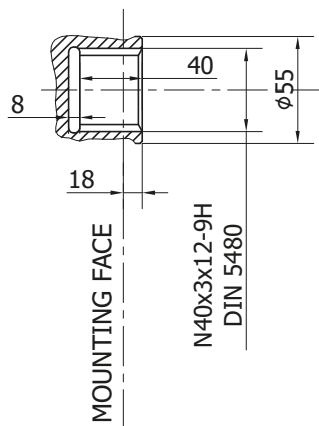

A31

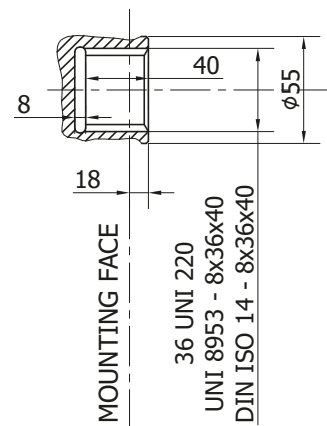

The data specified into the catalogue are for product description purpose only and must not be interpreted as warranted characteristics in legal sense. Italgrou S.r.l. reserves the right to implement modifications without notice. All partial or total reproduction and copy without written authorization of Italgrou S.r.l. is strictly forbidden.

SB3

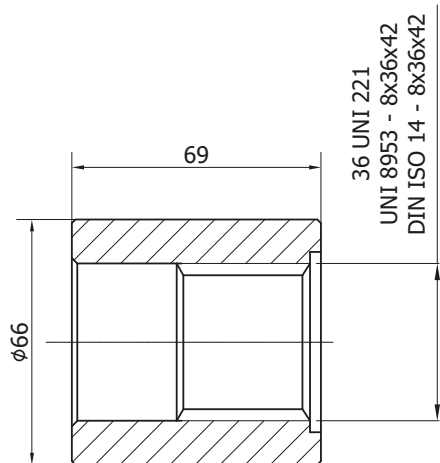

The data specified into the catalogue are for product description purpose only and must not be interpreted as warranted characteristics in legal sense. Italgroup S.r.l. reserves the right to implement modifications without notice. All partial or total reproduction and copy without written authorization of Italgroup S.r.l. is strictly forbidden.

INSTALLATION DRAWING

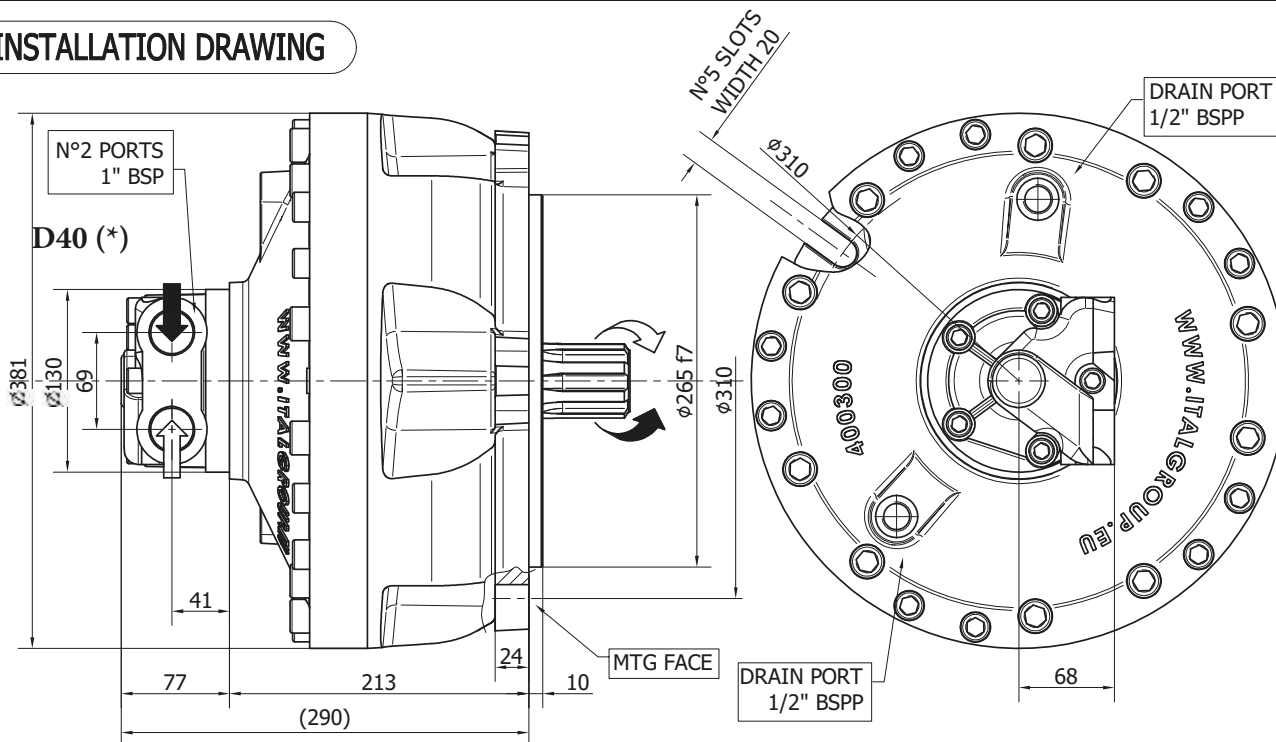

TECHNICAL DATA - HC 3

		350	400	500	600	700	800	900	1000
DISPLACEMENT	[cc]	352	426	486	595	689	792	872	988
SPECIFIC TORQUE	[Nm/bar]	5.60	6.78	7.73	9.47	10.98	12.60	13.90	15.70
MAX. CONT. PRESSURE	[bar]	250	250	250	250	250	250	250	250
MAX. INT. PRESSURE	[bar]	320	320	320	320	320	320	320	320
PEAK PRESSURE	[bar]	350	350	350	350	350	350	350	350
MAX. CONT. SPEED	[rpm]	640	600	500	450	420	400	360	310
PEAK SPEED (***)	[rpm]	800	800	700	600	600	550	525	500
MAX. CONT. POWER (****)	[kW]	85	85	85	85	85	85	85	85
PEAK POWER (*****)	[kW]	130	130	130	130	130	130	130	130
MAX. CASE PRESSURE	[bar]	6	6	6	6	6	6	6	6
DRY WEIGHT	[kg]	92	92	92	92	92	92	92	92
TEMPERATURE RANGE (**)	[°C]	-30÷70	-30÷70	-30÷70	-30÷70	-30÷70	-30÷70	-30÷70	-30÷70

- (*) The standard distributor (D40) is shown. Please refer to distributors section for different distributor interfaces.
- (**) Please refer to the hydraulic fluid recommendations.
- (***) Do not exceed peak power.
- (****) For motor operation with a continuous duty cycle at maximum continuous power the flushing is required.
- (*****) For motor operation at peak power flushing is usually required. For more information please contact our technical department.

The data specified into the catalogue are for product description purpose only and must not be interpreted as warranted characteristics in legal sense. Italgrou S.r.l. reserves the right to implement modifications without notice. All partial or total reproduction and copy without written authorization of Italgrou S.r.l. is strictly forbidden.

SHAFT CONFIGURATIONS

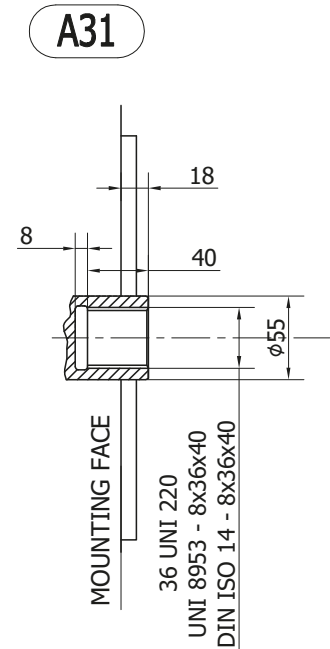
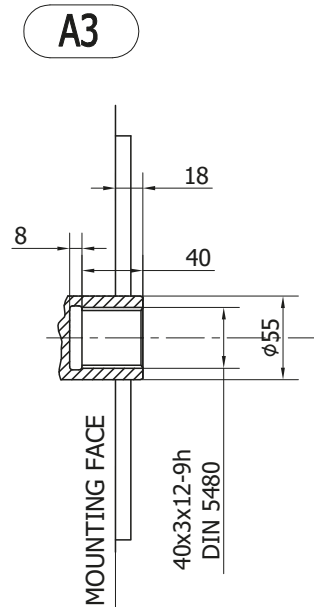
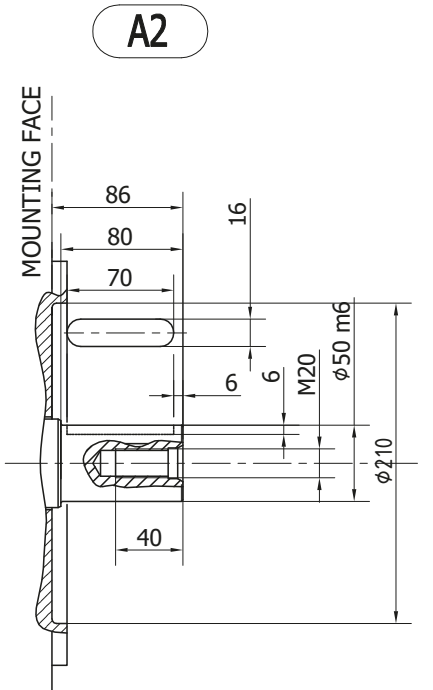
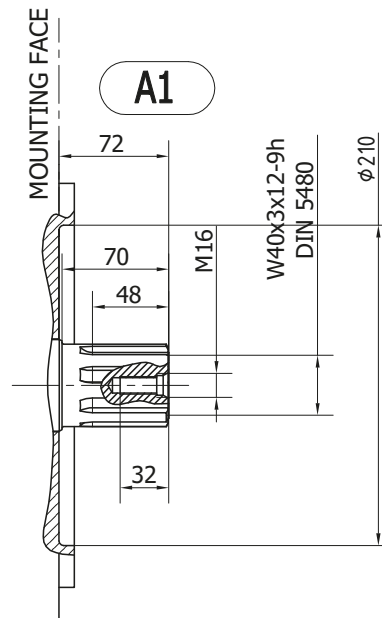
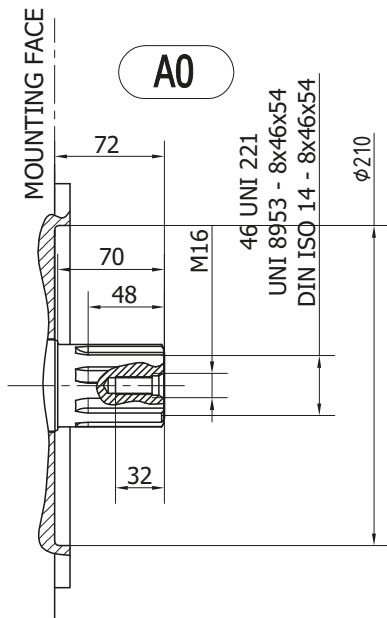

The data specified into the catalogue are for product description purpose only and must not be interpreted as warranted characteristics in legal sense. Italgroup S.r.l. reserves the right to implement modifications without notice. All partial or total reproduction and copy without written authorization of Italgroup S.r.l. is strictly forbidden.

SB5

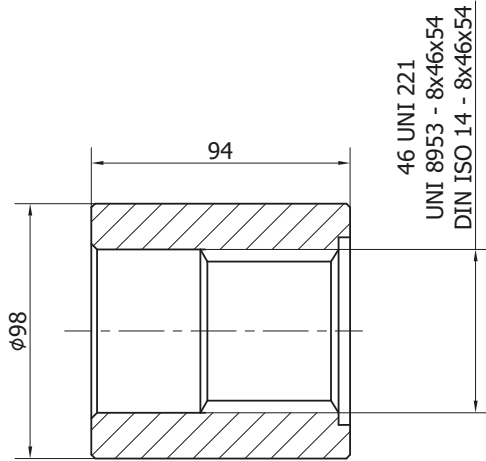

The data specified into the catalogue are for product description purpose only and must not be interpreted as warranted characteristics in legal sense. Italgroupp S.r.l. reserves the right to implement modifications without notice. All partial or total reproduction and copy without written authorization of Italgroupp S.r.l. is strictly forbidden.

INSTALLATION DRAWING

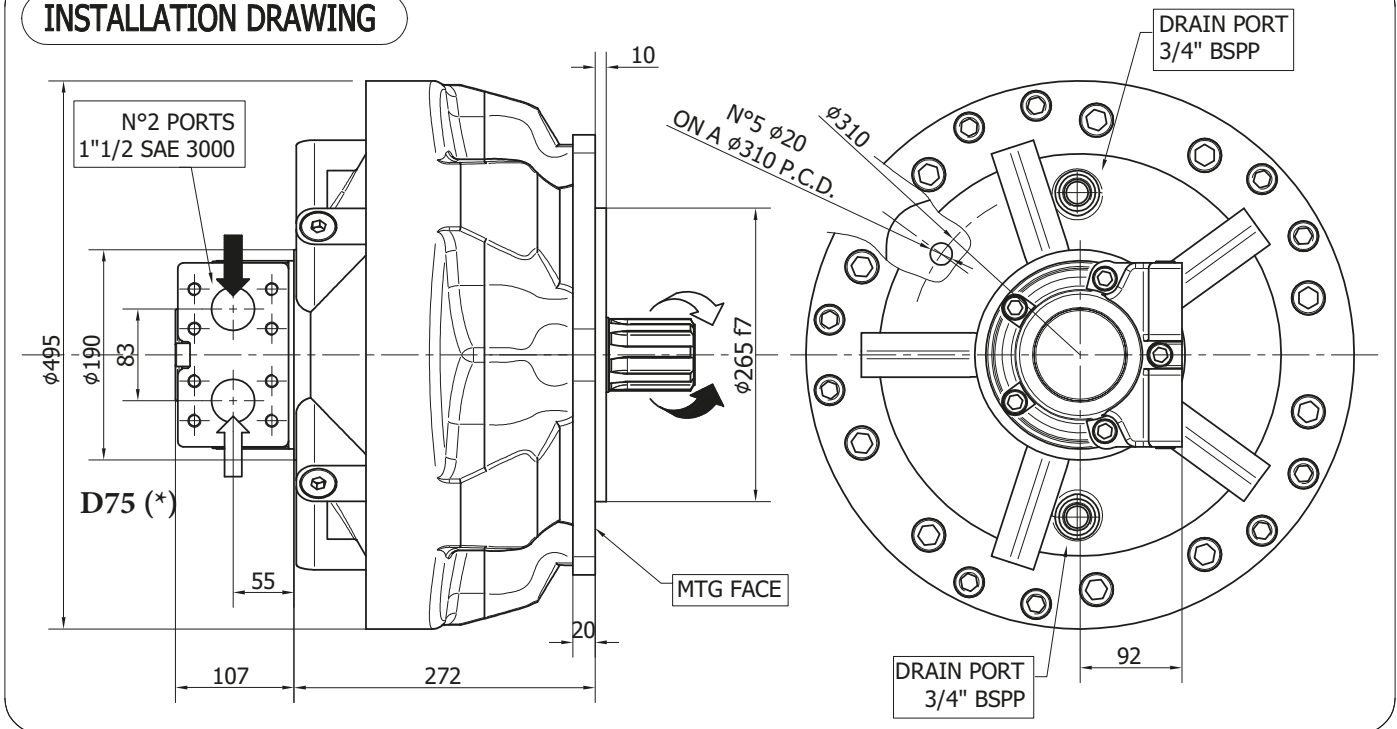

TECHNICAL DATA - HC 5

		800	1000	1200	1300	1500	1600	1800	2000
DISPLACEMENT	[cc]	808	1040	1190	1340	1464	1635	1816	2010
SPECIFIC TORQUE	[Nm/bar]	12.6	16.2	18.5	20.9	22.8	25.4	28.3	31.3
MAX. CONT. PRESSURE	[bar]	250	250	250	250	250	250	250	250
MAX. INT. PRESSURE	[bar]	320	320	320	320	320	320	320	320
PEAK PRESSURE	[bar]	350	350	350	350	350	350	350	350
MAX. CONT. SPEED	[rpm]	350	320	320	320	300	280	280	220
PEAK SPEED (***)	[rpm]	470	470	430	430	380	350	350	280
MAX. CONT. POWER (****)	[kW]	100	100	100	100	100	100	100	100
PEAK POWER (*****)	[kW]	150	150	150	150	150	150	150	150
MAX. CASE PRESSURE	[bar]	6	6	6	6	6	6	6	6
DRY WEIGHT	[kg]	178	178	178	178	178	178	178	178
TEMPERATURE RANGE (**)	[°C]	-30÷70	-30÷70	-30÷70	-30÷70	-30÷70	-30÷70	-30÷70	-30÷70

- (*) The standard distributor (D75) is shown. Please refer to distributors section for different distributor interfaces.
- (**) Please refer to the hydraulic fluid recommendations.
- (***) Do not exceed peak power.
- (****) For motor operation with a continuous duty cycle at maximum continuous power the flushing is required.
- (*****) For motor operation at peak power flushing is usually required. For more information please contact our technical department.

The data specified into the catalogue are for product description purpose only and must not be interpreted as warranted characteristics in legal sense. Italgrou S.r.l. reserves the right to implement modifications without notice. All partial or total reproduction and copy without written authorization of Italgrou S.r.l. is strictly forbidden.

SHAFT CONFIGURATIONS

A0

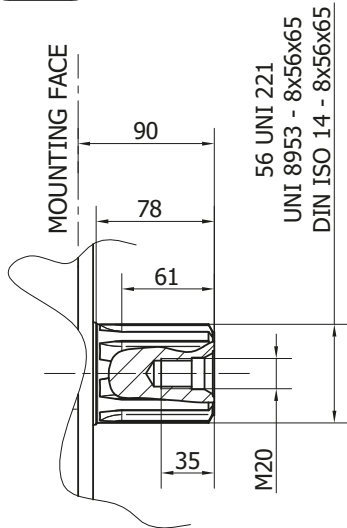

A1

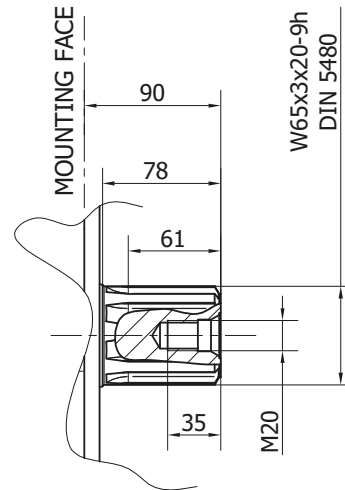

A2

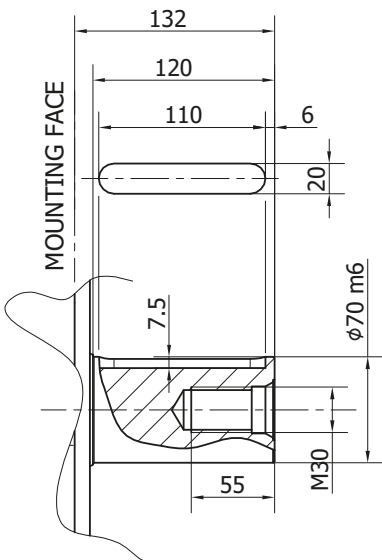

A3

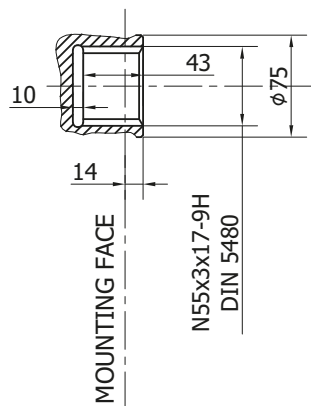

A31

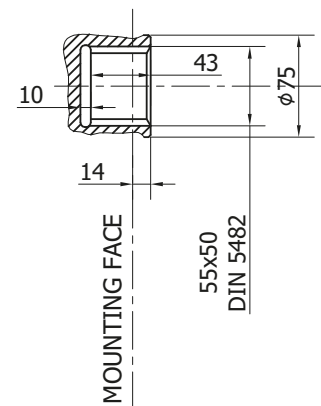

The data specified into the catalogue are for product description purpose only and must not be interpreted as warranted characteristics in legal sense. Italgroup S.r.l. reserves the right to implement modifications without notice. All partial or total reproduction and copy without written authorization of Italgroup S.r.l. is strictly forbidden.

SB17

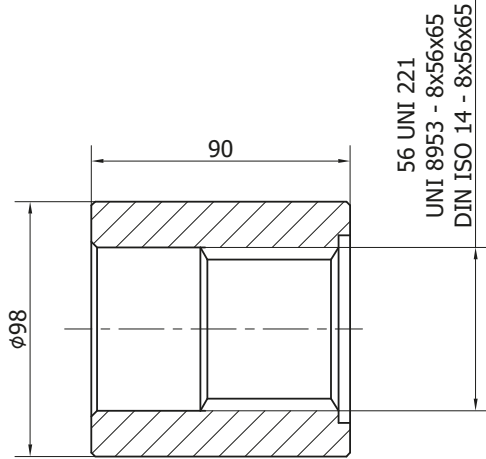

The data specified into the catalogue are for product description purpose only and must not be interpreted as warranted characteristics in legal sense. Italgroupp S.r.l. reserves the right to implement modifications without notice. All partial or total reproduction and copy without written authorization of Italgroupp S.r.l. is strictly forbidden.

ORDERING INSTRUCTIONS

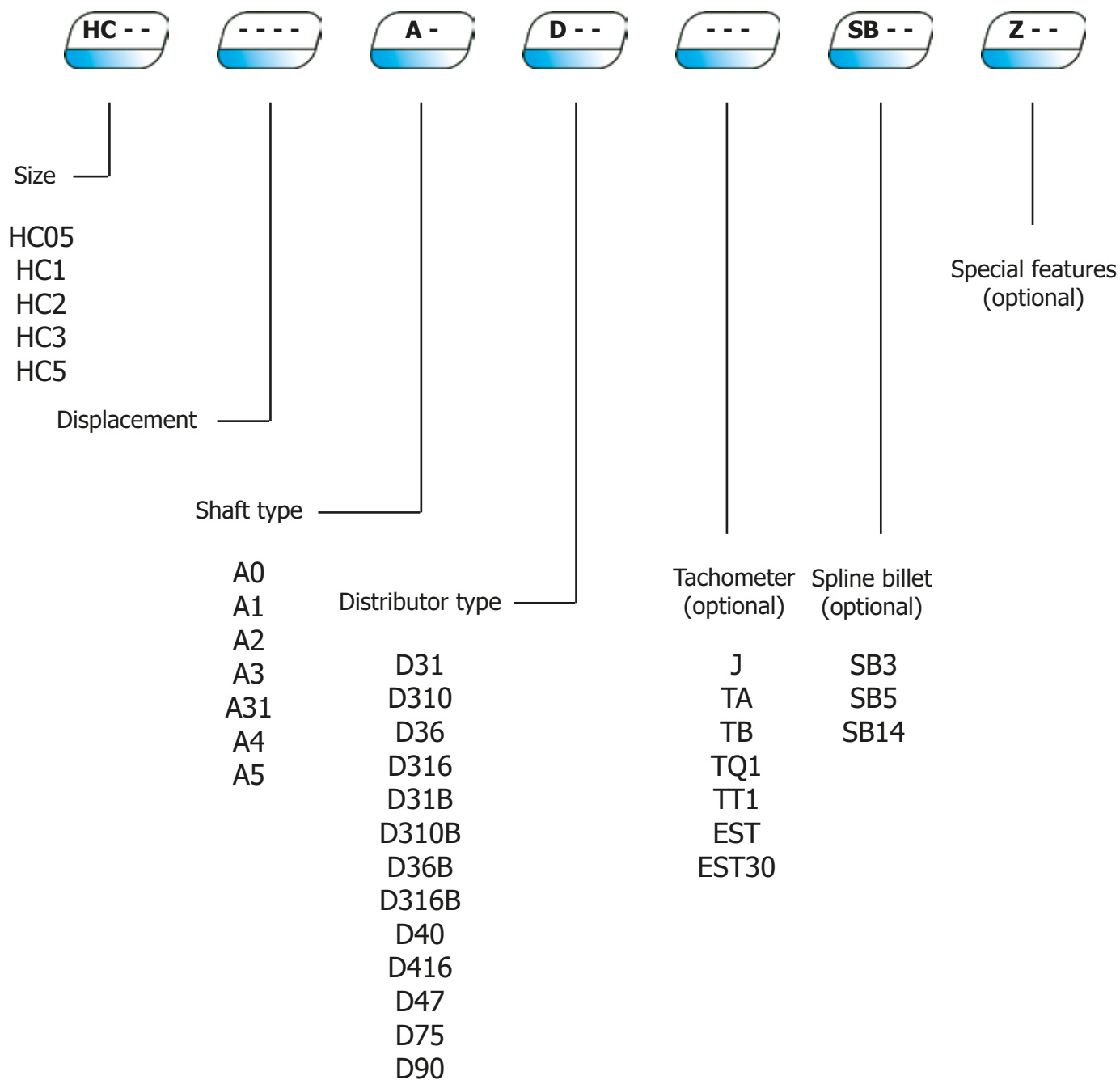

Examples:

HC05.150.A0.D40.J
HC3.400.A2.D47.TB
HC2.200.A31.D416

The data specified into the catalogue are for product description purpose only and must not be interpreted as warranted characteristics in legal sense. Italgroupp S.r.l. reserves the right to implement modifications without notice. All partial or total reproduction and copy without written authorization of Italgroupp S.r.l. is strictly forbidden.

D31

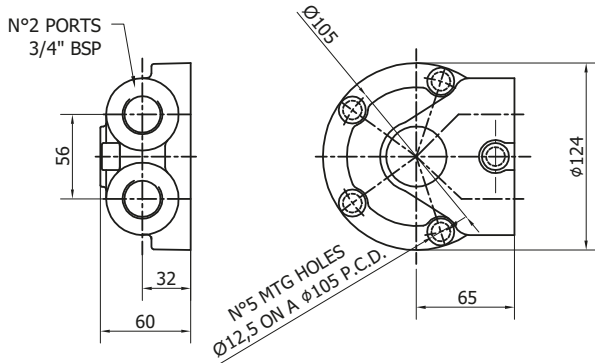

D310

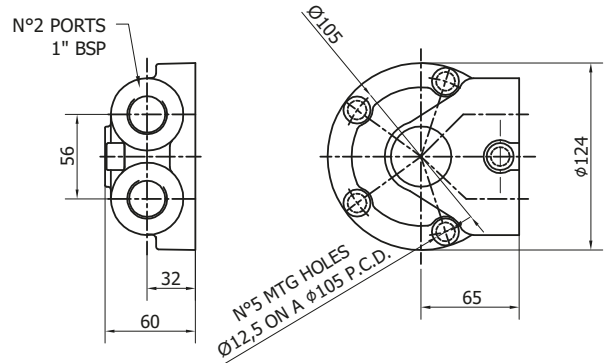

D36

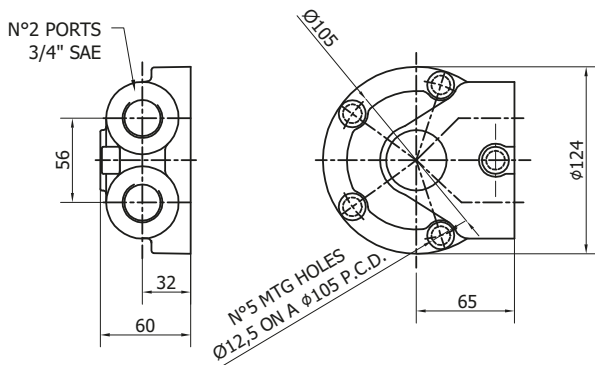

D316

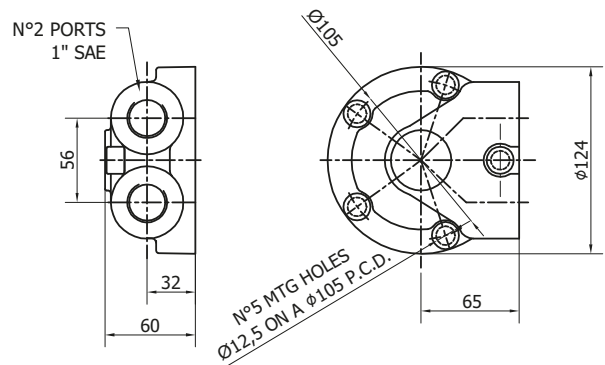

D31B

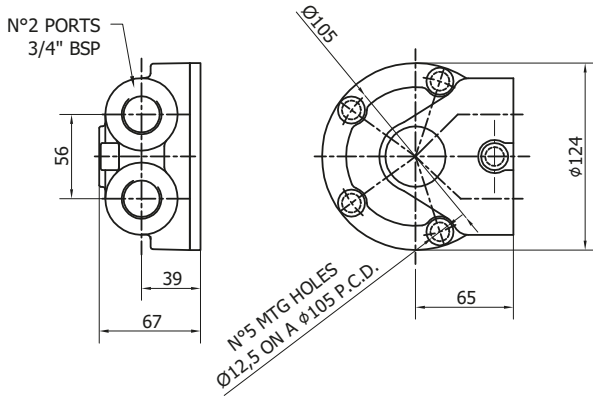

D310B

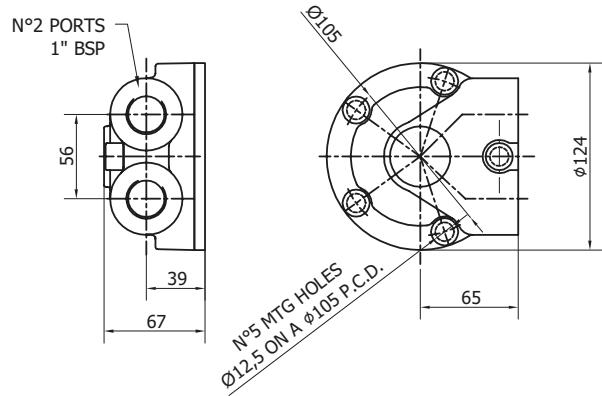

D36B

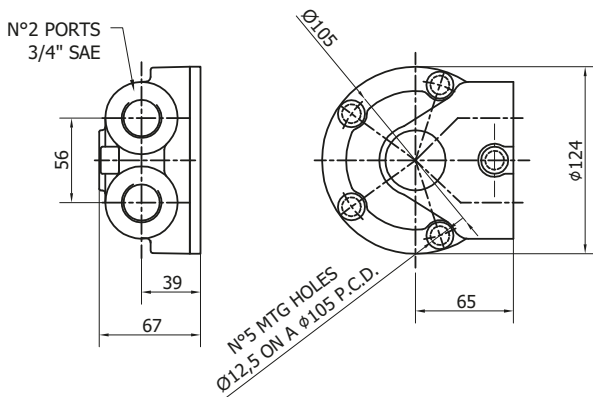

D316B

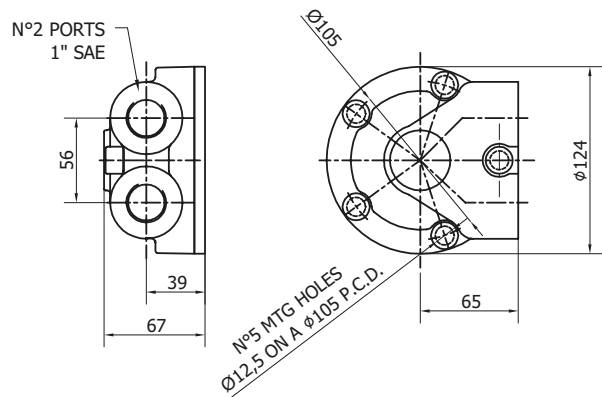

The data specified into the catalogue are for product description purpose only and must not be interpreted as warranted characteristics in legal sense. Italgroup S.r.l. reserves the right to implement modifications without notice. All partial or total reproduction and copy without written authorization of Italgroup S.r.l. is strictly forbidden.

D40

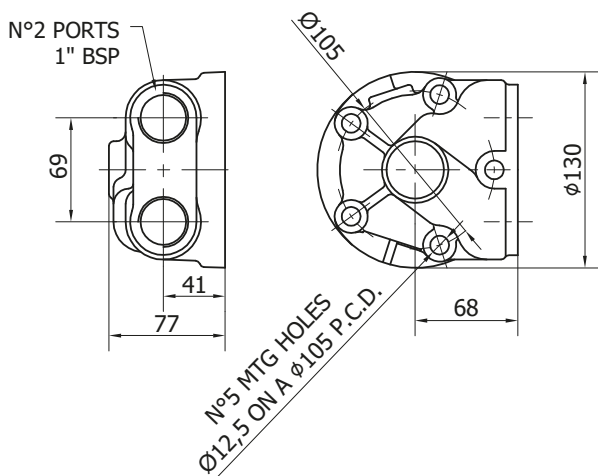

D416

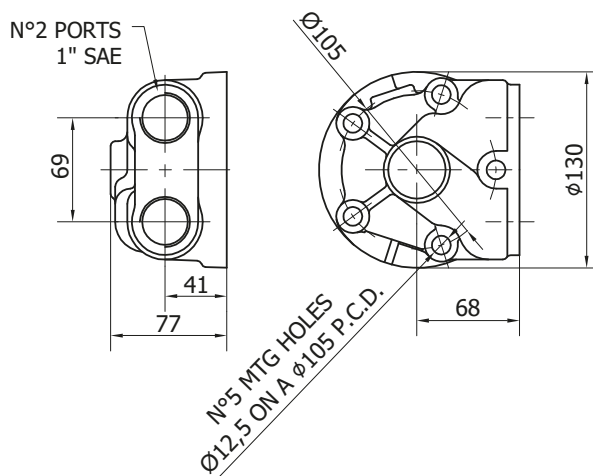

D47

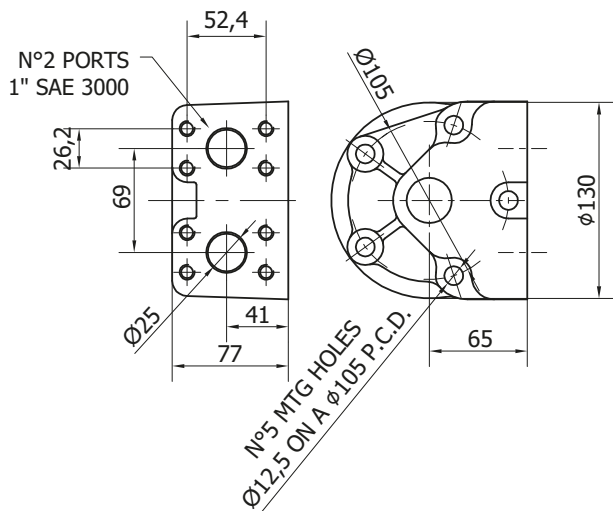

D75

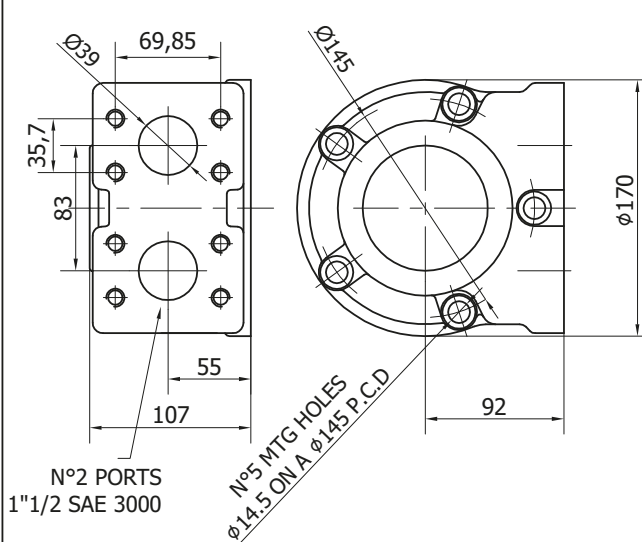

The data specified into the catalogue are for product description purpose only and must not be interpreted as warranted characteristics in legal sense. Italgroup S.r.l. reserves the right to implement modifications without notice. All partial or total reproduction and copy without written authorization of Italgroup S.r.l. is strictly forbidden.

FLOW DISTRIBUTORS

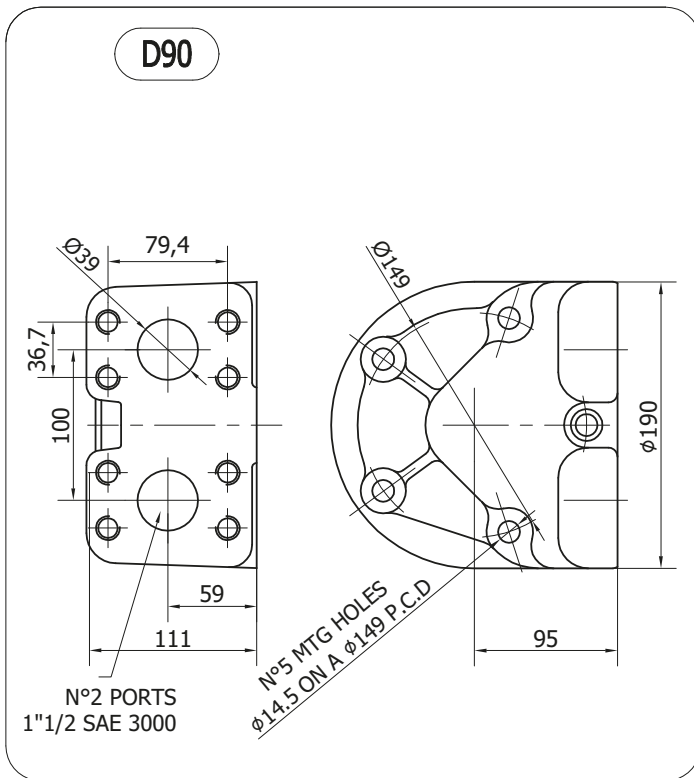

		D31	D310	D36	D316	D31B	D310B	D36B	D316B	D40	D416	D47	D75	D90
		(*)	(*)	(*)	(*)									
MAX. CONT. FLOW	[l/min]	200	200	200	200	200	200	200	200	200	200	200	500	600
MAX. FLOW	[l/min]	400	400	400	400	400	400	400	400	400	400	400	1000	1200
MAX. CONT. PRESSURE	[bar]	250	250	250	250	250	250	250	250	250	250	250	250	250
PEAK PRESSURE	[bar]	500	500	500	500	500	500	500	500	500	500	500	500	500
HC05		●	●	●	●	●	●	●	●	●	●	●		
HC1		●	●	●	●	●	●	●	●	●	●	●		
HC2		●	●	●	●	●	●	●	●	●	●	●		
HC3		●	●	●	●	●	●	●	●	●	●	●		
HC5		◐	◐	◐	◐	◐	◐	◐	◐	◐	◐	◐	●	●



Standard version



Special version: available on request. Please contact Italgroup for more details

- (*) When is possible, always select corresponding B version (D31B, D310B, D36B or D316B) Please contact Italgroup for more information.

The data specified into the catalogue are for product description purpose only and must not be interpreted as warranted characteristics in legal sense. Italgroup S.r.l. reserves the right to implement modifications without notice. All partial or total reproduction and copy without written authorization of Italgroup S.r.l. is strictly forbidden.

TA

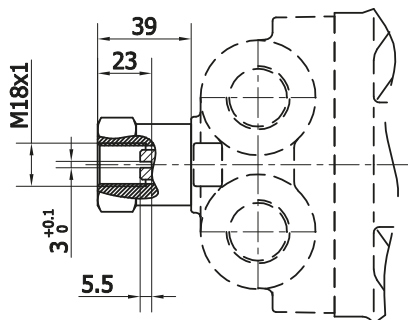

TB

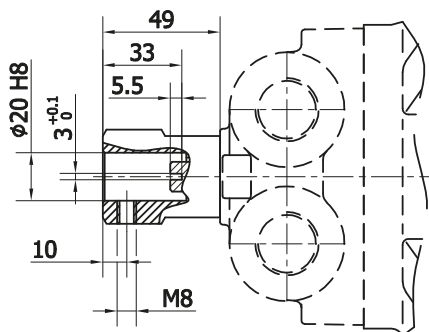

TQ1

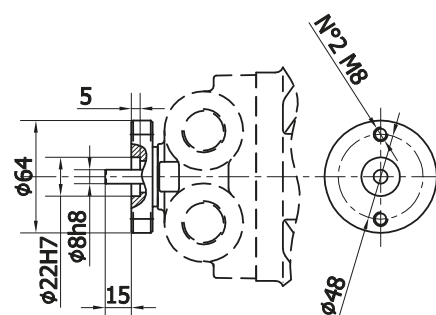

TT1

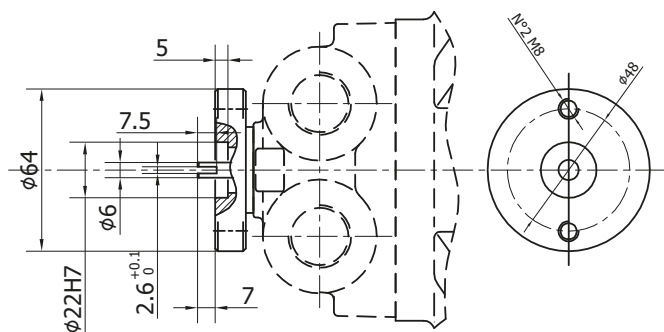

EST

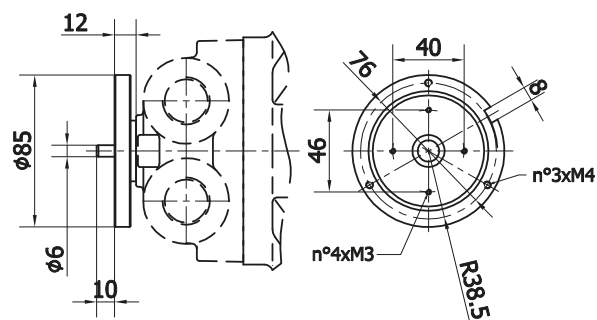

EST30

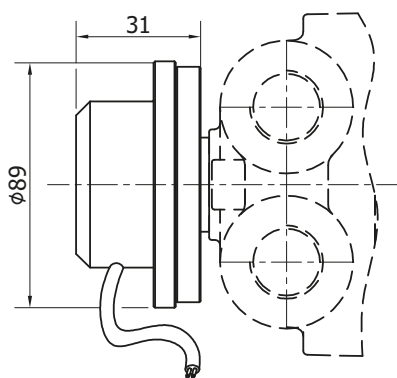

Operating parameters	E-..../3
Power supply (VDC)	10-30
Switching current (mA)	150
Frequency (Hz) 100rpm	50
Impulse/rpm	30
Operating temp. (°C)	-24/+70
Protection degree	IP67
Output	NPN
Motor type	All types
MODEL	Ø5
Torque	1 Nm

Model	Output	Fig.
E-..../.AP/....	PNP	D

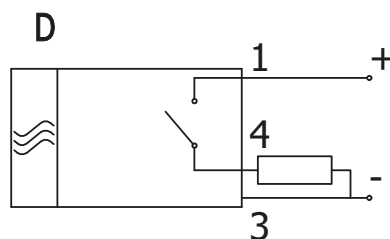

The data specified into the catalogue are for product description purpose only and must not be interpreted as warranted characteristics in legal sense. ItalgrouP S.r.l. reserves the right to implement modifications without notice. All partial or total reproduction and copy without written authorization of ItalgrouP S.r.l. is strictly forbidden.

SINGLE OVERCENTER VALVE - OVSA 160

INSTALLATION DRAWING

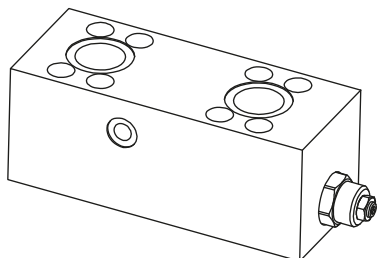

PORTS DIMENSION

V1,V2	1" BSP
F	1/4" BSP
C1,C2	O-ring 4137 Parker code 2-220

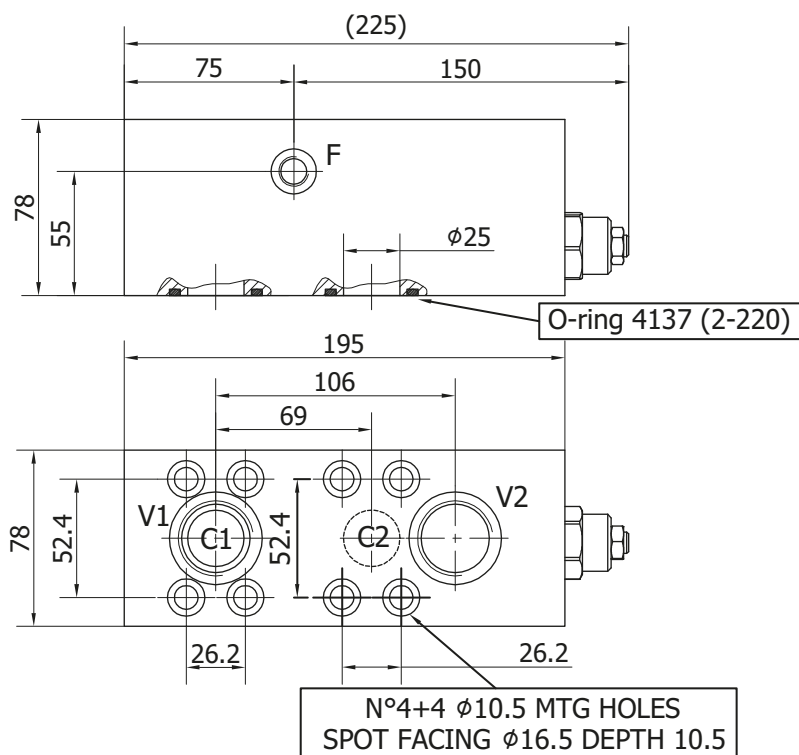

TECHNICAL DATA - OVSA 160

		OVSA.160.1.B.D47 (*)	OVSA.160.2.C.D47	OVSA.160.3.C.D47
NOMINAL FLOW	[l/min]	120	120	120
MAXIMUM FLOW	[l/min]	160	160	160
MAXIMUM PRESSURE	[bar]	350	350	350
PILOT RATIO	[-]	3:1	4.5:1	10:1
RELIEF VALVE SETTING RANGE	[bar]	70-280	140-350	140-350
STANDARD RELIEF SETTING	[bar]	210	210	210
BLOCK MATERIAL	[-]	steel	steel	steel
DISTRIBUTOR FITTING	[-]	D47	D47	D47

- (*) Standard version. Usually ready on stock.

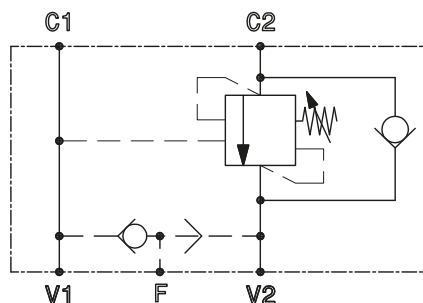
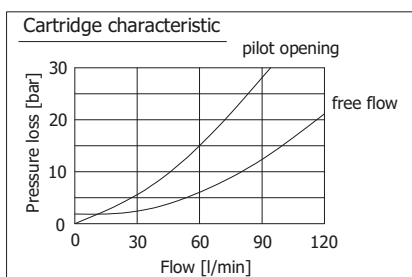

The data specified into the catalogue are for product description purpose only and must not be interpreted as warranted characteristics in legal sense. Italgrou S.r.l. reserves the right to implement modifications without notice. All partial or total reproduction and copy without written authorization of Italgrou S.r.l. is strictly forbidden.

DOUBLE OVERCENTER VALVE - OVDA 160

INSTALLATION DRAWING

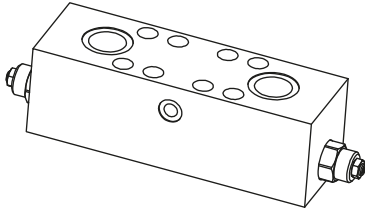

PORTS DIMENSION

V1,V2	1" BSP
F	1/4" BSP
C1,C2	O-ring 4137 Parker code 2-220

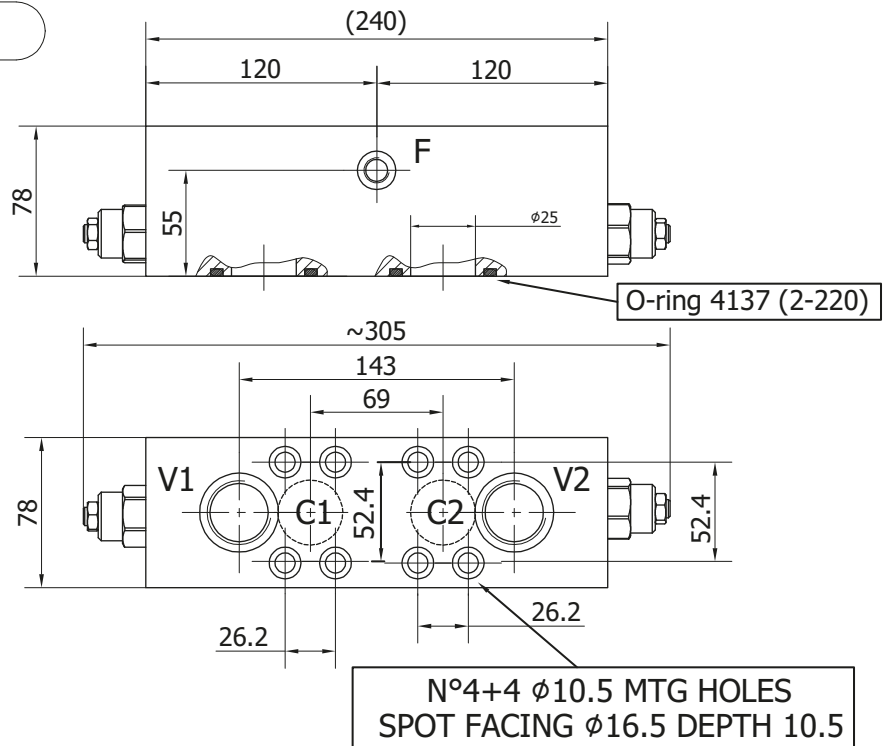

TECHNICAL DATA - OVDA 160

		OVDA.160.1.B.D47 (*)	OVDA.160.2.C.D47	OVDA.160.3.C.D47
NOMINAL FLOW	[l/min]	120	120	120
MAXIMUM FLOW	[l/min]	160	160	160
MAXIMUM PRESSURE	[bar]	350	350	350
PILOT RATIO	[-]	3:1	4.5:1	10:1
RELIEF VALVE SETTING RANGE	[bar]	70-280	140-350	140-350
STANDARD RELIEF SETTING	[bar]	210	210	210
BLOCK MATERIAL	[-]	steel	steel	steel
DISTRIBUTOR FITTING	[-]	D47	D47	D47

- (*) Standard version. Usually ready on stock.

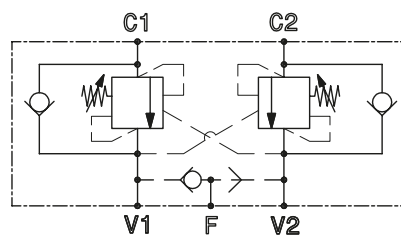
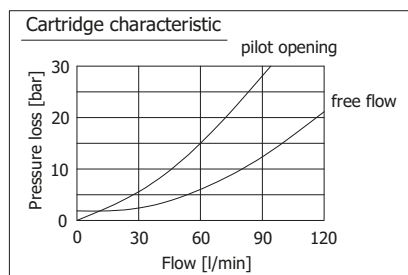

The data specified into the catalogue are for product description purpose only and must not be interpreted as warranted characteristics in legal sense. Italgroup S.r.l. reserves the right to implement modifications without notice. All partial or total reproduction and copy without written authorization of Italgroup S.r.l. is strictly forbidden.

FLUSHING VALVE - AP40

INSTALLATION DRAWING

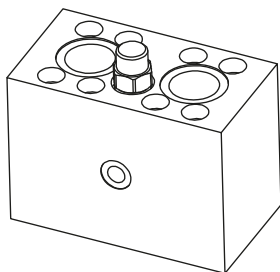

PORTS DIMENSION

V1,V2	1" BSP
F	1/4" BSP
C1,C2	O-ring 4137 Parker code 2-220

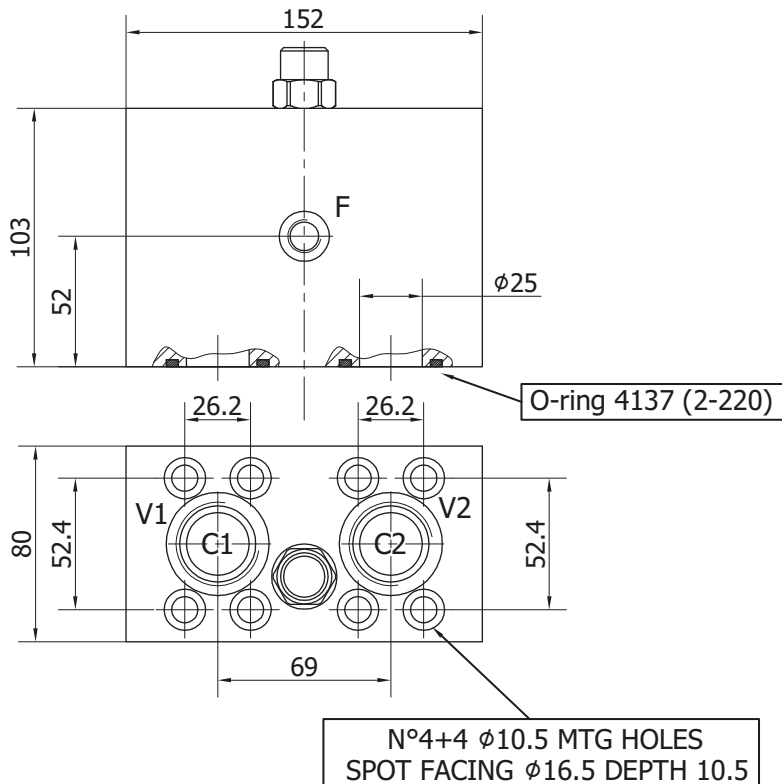

TECHNICAL DATA - AP40

		AP40.D47
MAXIMUM FLUSHING FLOW	[l/min]	80
MAXIMUM PRESSURE	[bar]	350
BLOCK MATERIAL	[]	steel
DISTRIBUTOR FITTING	[]	D47

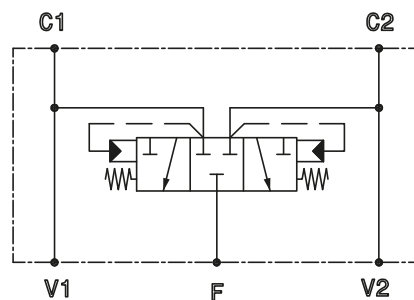
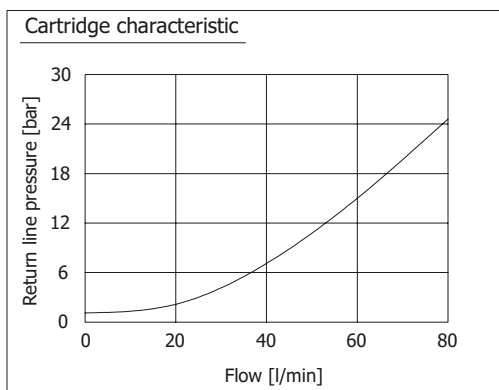

The data specified into the catalogue are for product description purpose only and must not be interpreted as warranted characteristics in legal sense. Italgrou S.r.l. reserves the right to implement modifications without notice. All partial or total reproduction and copy without written authorization of Italgrou S.r.l. is strictly forbidden.

DOUBLE RELIEF VALVE- RVDA 80

INSTALLATION DRAWING

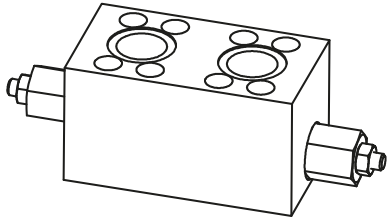

PORTS DIMENSION

V1,V2	1" BSP
C1,C2	O-ring 4137 Parker code 2-220

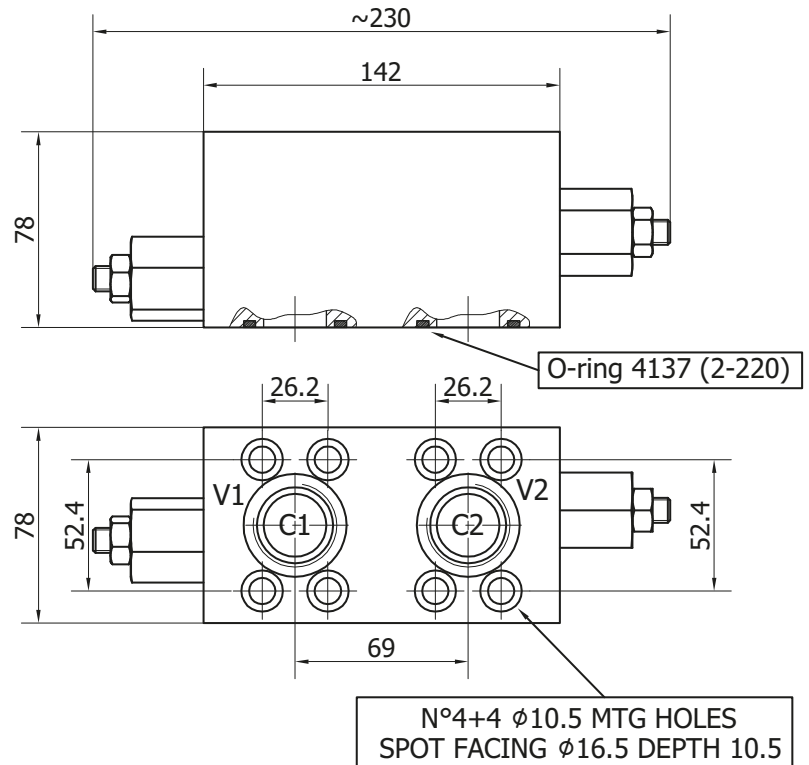

TECHNICAL DATA - RVDA 80-200

RVDA.80.C.D47-200 (*)

NOMINAL FLOW	[l/min]	150
MAXIMUM FLOW	[l/min]	200
MAXIMUM PRESSURE	[bar]	350
RELIEF VALVE SETTING RANGE	[bar]	20-350
STANDARD RELIEF SETTING	[bar]	20
BLOCK MATERIAL	[]	steel
DISTRIBUTOR FITTING	[]	D47

- (*) Standard version. Usually ready on stock.

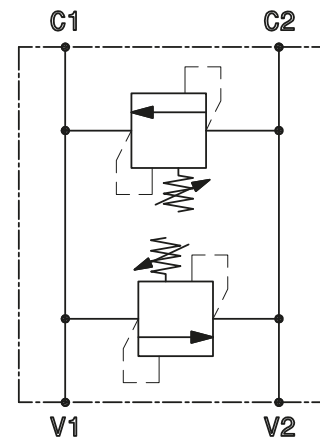
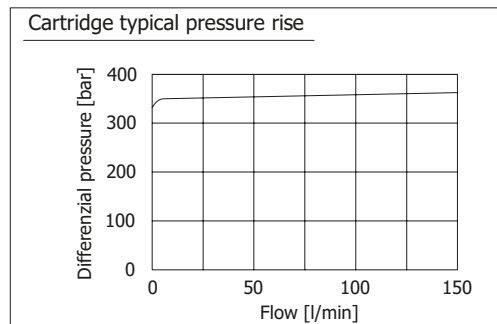

The data specified into the catalogue are for product description purpose only and must not be interpreted as warranted characteristics in legal sense. Italgroup S.r.l. reserves the right to implement modifications without notice. All partial or total reproduction and copy without written authorization of Italgroup S.r.l. is strictly forbidden.

DOUBLE OVERCENTER VALVE - OVDA 300

INSTALLATION DRAWING

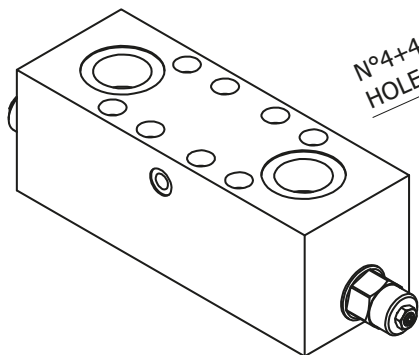

N°4+4 MTG HOLES Ø12,5

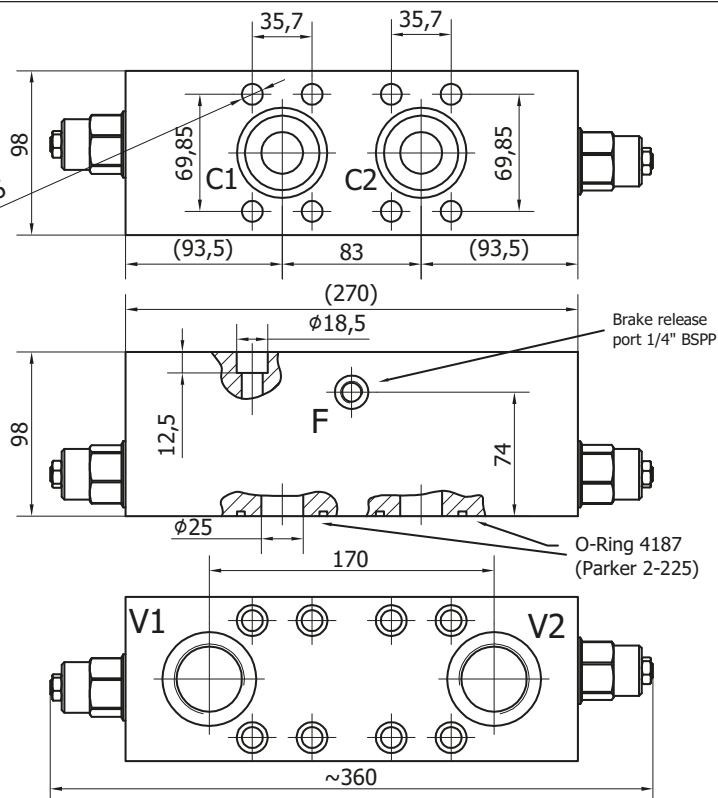

PORTS DIMENSION

V1,V2	1"1/4 BSPP
F	1/4" BSPP
C1,C2	O-ring 4187 Parker code 2-225

TECHNICAL DATA - OVDA 300

		OVDA.300.1.A.D75 (*)	OVDA.300.4.B.D75	OVDA.300.2.C.D75
NOMINAL FLOW	[l/min]	240	240	240
MAXIMUM FLOW	[l/min]	300	300	300
MAXIMUM PRESSURE	[bar]	350	350	350
PILOT RATIO	[-]	3:1	10:1	4.5:1
RELIEF VALVE SETTING RANGE	[bar]	70-280	140-350	140-350
STANDARD RELIEF SETTING	[bar]	210	210	210
BLOCK MATERIAL	[-]	steel	steel	steel
DISTRIBUTOR FITTING	[-]	D75	D75	D75

- (*) Standard version. Usually ready on stock.

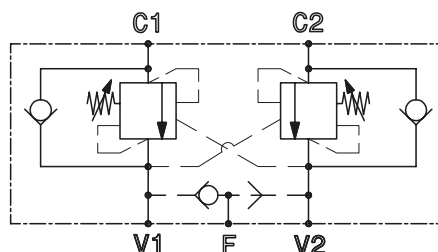
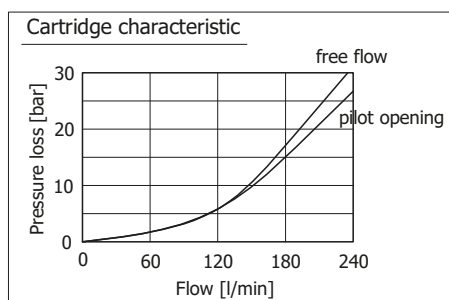

The data specified into the catalogue are for product description purpose only and must not be interpreted as warranted characteristics in legal sense. Italgrou S.r.l. reserves the right to implement modifications without notice. All partial or total reproduction and copy without written authorization of Italgrou S.r.l. is strictly forbidden.

DOUBLE RELIEF VALVE- RVDA 200

INSTALLATION DRAWING

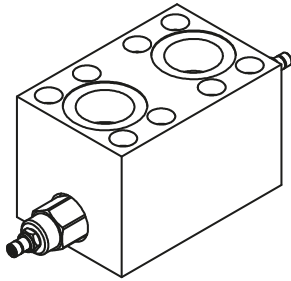

PORTS DIMENSION

V1,V2	1"1/4 BSP
C1,C2	O-ring 4187 Parker code 2-225

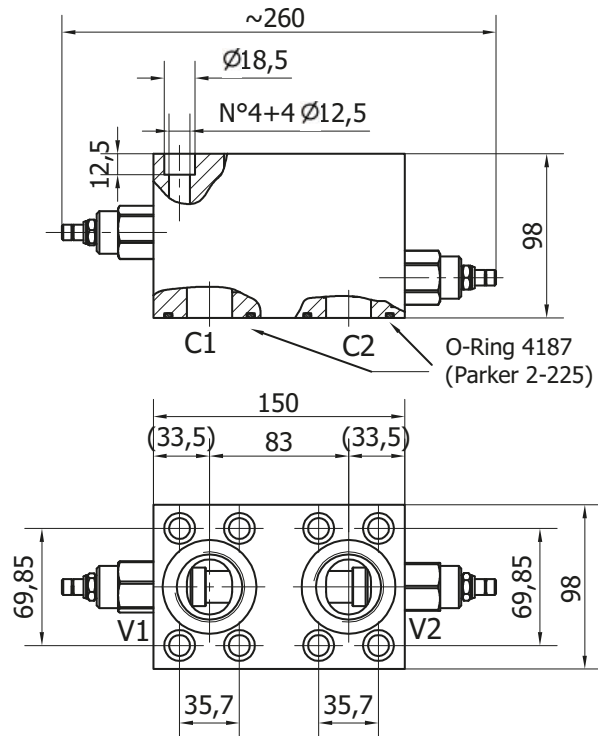

TECHNICAL DATA - RVDA 200

RVDA.200.C.D75		
RELIEF VALVE MAXIMUM FLOW	[l/min]	200
MAXIMUM PRESSURE	[bar]	350
RELIEF VALVE SETTING RANGE	[bar]	70-420
STANDARD RELIEF SETTING	[bar]	70
BLOCK MATERIAL	[]	steel
DISTRIBUTOR FITTING	[]	D75

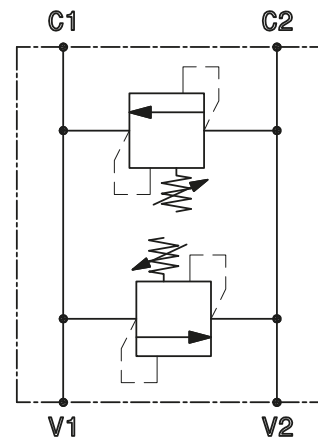
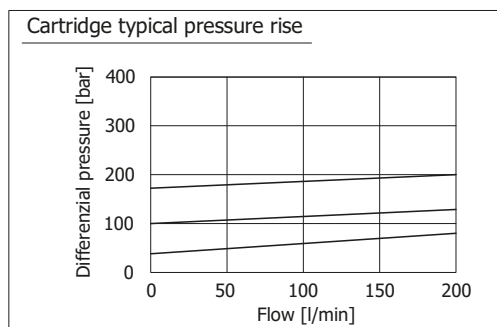

The data specified into the catalogue are for product description purpose only and must not be interpreted as warranted characteristics in legal sense. Italgrou S.r.l. reserves the right to implement modifications without notice. All partial or total reproduction and copy without written authorization of Italgrou S.r.l. is strictly forbidden.

DOUBLE OVERCENTER VALVE - OVDA 480

INSTALLATION DRAWING

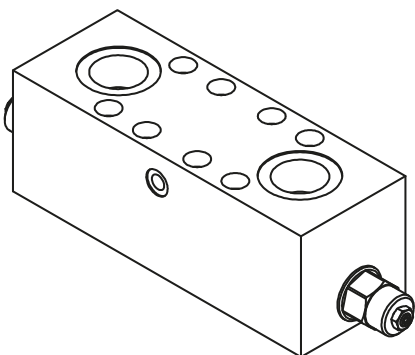

PORTS DIMENSION

V1,V2	1"1/2 BSPP
F	1/4" BSPP
C1,C2	O-ring 4187 Parker code 2-225

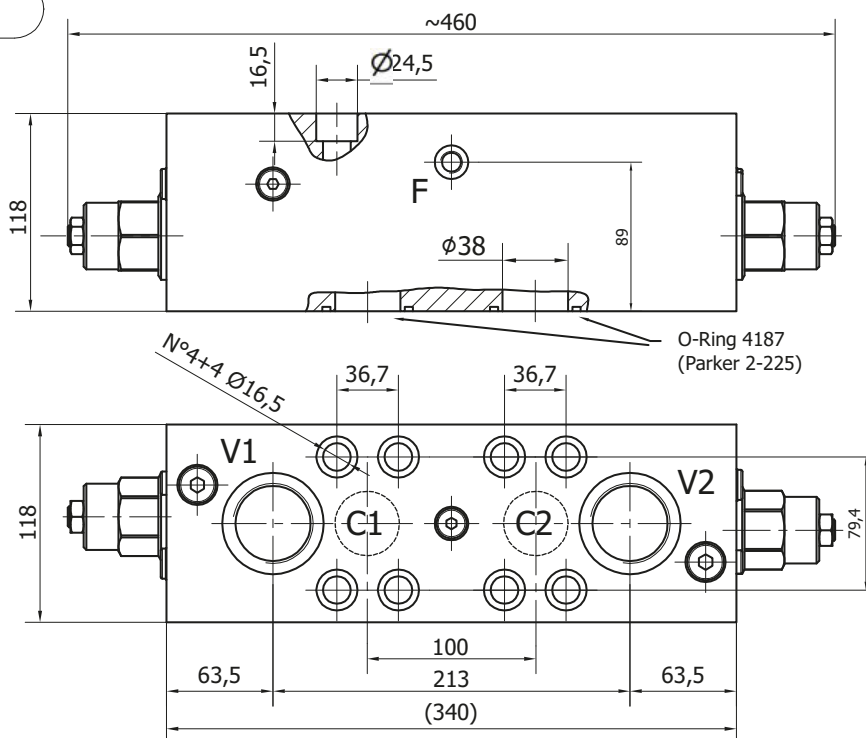

TECHNICAL DATA - OVDA 480

		OVDA.480.1.A.D90 (*)	OVDA.480.4.B.D90	OVDA.480.2.C.D90
NOMINAL FLOW	[l/min]	480	480	480
MAXIMUM FLOW	[l/min]	600	600	600
MAXIMUM PRESSURE	[bar]	350	350	350
PILOT RATIO	[]	3:1	10:1	4.5:1
RELIEF VALVE SETTING RANGE	[bar]	70-280	140-350	140-350
STANDARD RELIEF SETTING	[bar]	210	210	210
BLOCK MATERIAL	[]	steel	steel	steel
DISTRIBUTOR FITTING	[]	D90	D90	D90

- (*) Standard version. Usually ready on stock.

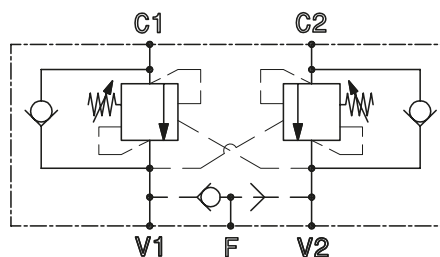
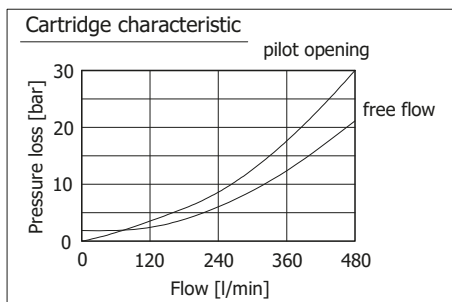

The data specified into the catalogue are for product description purpose only and must not be interpreted as warranted characteristics in legal sense. Italgrou S.r.l. reserves the right to implement modifications without notice. All partial or total reproduction and copy without written authorization of Italgrou S.r.l. is strictly forbidden.

DOUBLE RELIEF VALVE- RVDA 380

INSTALLATION DRAWING

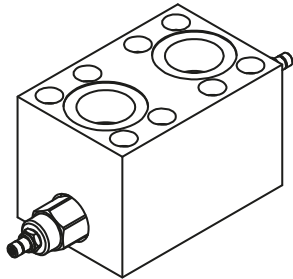

PORTS DIMENSION

V1,V2	1"1/2 BSP
C1,C2	O-ring 4187 Parker code 2-225

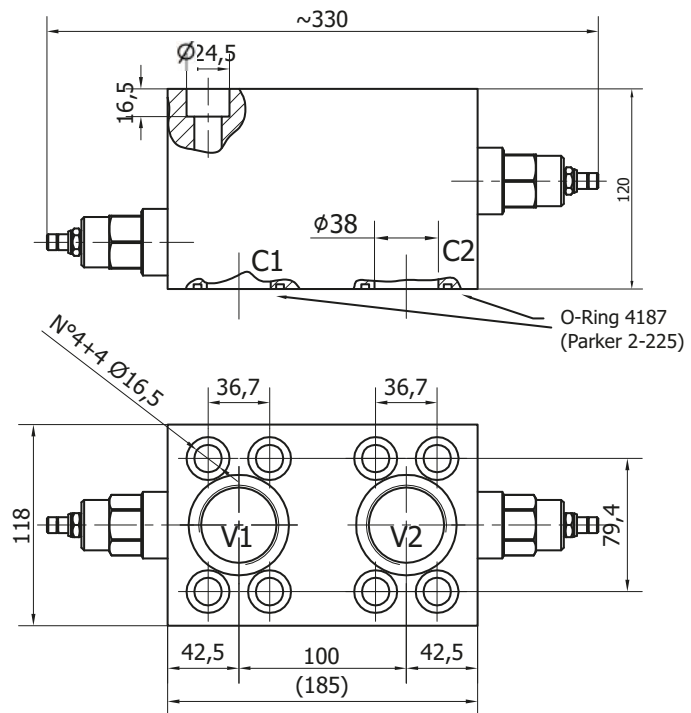

TECHNICAL DATA - RVDA 380

		RVDA.380.C.D90
RELIEF VALVE MAXIMUM FLOW	[l/min]	380
MAXIMUM PRESSURE	[bar]	350
RELIEF VALVE SETTING RANGE	[bar]	70-420
STANDARD RELIEF SETTING	[bar]	70
BLOCK MATERIAL	[]	steel
DISTRIBUTOR FITTING	[]	D90

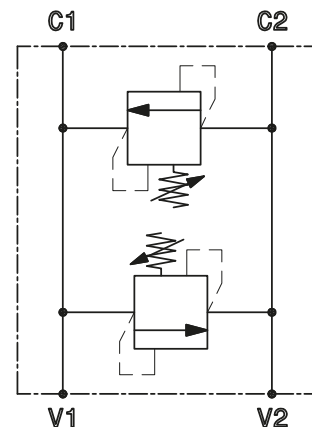
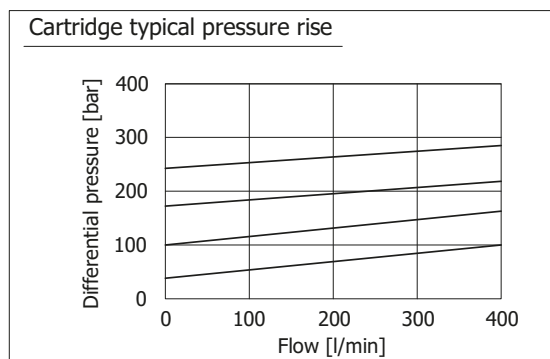

The data specified into the catalogue are for product description purpose only and must not be interpreted as warranted characteristics in legal sense. Italgroup S.r.l. reserves the right to implement modifications without notice. All partial or total reproduction and copy without written authorization of Italgroup S.r.l. is strictly forbidden.

DOUBLE RELIEF WITH FLUSHING - RVDAP 90

INSTALLATION DRAWING

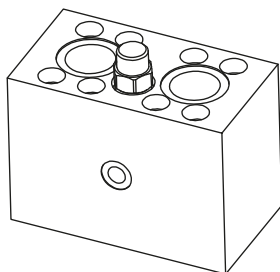

PORTS DIMENSION

V1,V2	1"1/2 BSP
F	1/4" BSP
C1,C2	O-ring 4187 Parker code 2-225

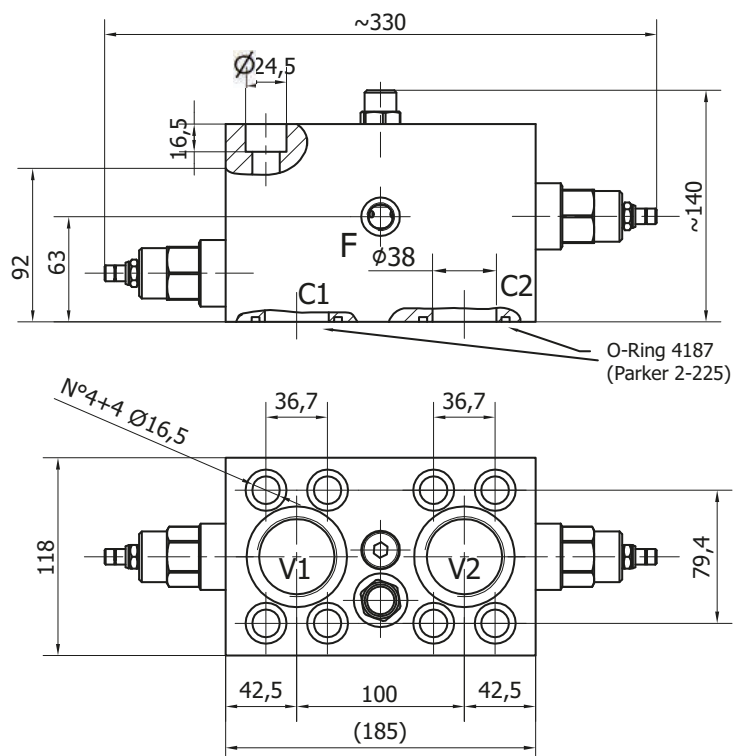

TECHNICAL DATA - RVDAP 90

		RVDAP 90
RELIEF VALVE MAXIMUM FLOW	[l/min]	380
RELIEF VALVE SETTING RANGE	[bar]	70-420
STANDARD RELIEF SETTING	[bar]	70
MAXIMUM FLUSHING FLOW	[l/min]	80
MAXIMUM PRESSURE	[bar]	350
BLOCK MATERIAL	□	steel
DISTRIBUTOR FITTING	□	D90

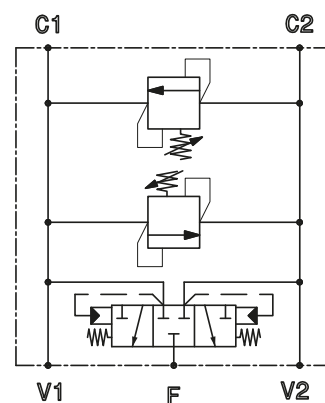

Relief valve typical pressure rise

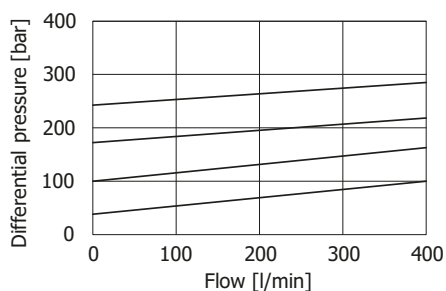

Flushing cartridge characteristic

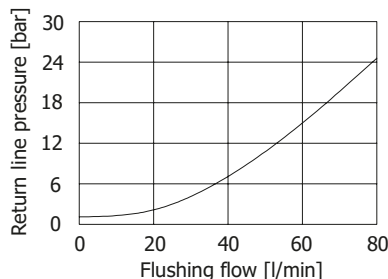

The data specified into the catalogue are for product description purpose only and must not be interpreted as warranted characteristics in legal sense. Italgroup S.r.l. reserves the right to implement modifications without notice. All partial or total reproduction and copy without written authorization of Italgroup S.r.l. is strictly forbidden.

CONTACT US

Italgroup S.r.l.
Via Pacinotti 20/22
41010 - Gaggio di Piano (Modena) – Italy

Tel. +39 059 92 42 57
Fax +39 059 92 01 13
e-mail: italgroup@italgroup.eu
internet: <http://www.italgroup.eu>

REACH US



Europe

Austria
Belgium
Croatia
Czech Republic
Cyprus
Denmark
Faroe Islands
France
Finland
Germany
Greece
Iceland
Italy
Netherlands
Norway
Poland
Portugal
Russia
Slovenia
Spain
Sweden
Switzerland
Turkey
Ukraine
United Kingdom

Africa

Egypt
South Africa
Tunisia

America

Argentina
Brazil
Canada
Chile
Mexico
Peru
USA
Colombia

Asia

China
Hong Kong
India
Indonesia
Iran
Israel
Philippines
Russia
Belarus
Singapore
South Korea
Thailand
Taiwan
United Arab Emirates
Vietnam

Oceania

Australia
New Zealand

