

SAM 010-130 DIN is a series of light weight casing axial piston motors, particularly suitable for mobile hydraulics. SAM 010-130 DIN is of the bent-axis type with spherical pistons.

The design gives a compact motor with few moving parts, high starting torque and high operational reliability. It covers the entire displacement range 10-130 cm³/rev. with max. pressure 400 bar.

It's high level of reliability is due to the choice of materials, hardening methods, surface structures and the quality assured manufacturing process.

Other advantages:

- Light weight metal casing design
- Smooth operation over the entire speed range
- High efficiency
- Suitable for applications with high angular accelerations due to its high rotary stiffness
- Corrosion free light metal-housing
- Less heat generation due to better ability to dissipate heat through housing

Versions, main data

Example

SA	M	-	012	W	-	N	-	DL4	-	L35	-	S3	G	-	1	00
Line	1		2	3		4		5		6		7	8		9	10

Line	SA	Sunfab Aluminium
------	----	------------------

1. Type	M	Motor
---------	---	-------

2. Displacement	010	012	017	025	034	040	047	056	064	084	090	108	130
-----------------	-----	-----	-----	-----	-----	-----	-----	-----	-----	-----	-----	-----	-----

3. Direction of rotation	W	Independent
--------------------------	---	-------------

4. Sealing	N	Nitrile
------------	---	---------

5. Mounting flange	ISO 7653-D
DL4	ø 80

6. Shaft	DIN 5462 / ISO 14
L35	8x32x34.9

7. Connection cover		010	012	017	025	034	040	047	056	064	084	090	108	130
S3	40° threaded connection	X	X	X	X	X	X	X	X	X	X	X	X	X

8. Connections		010	012	017	025	034	040	047	056	064	084	090	108	130
G	ISO G	X	X	X	X	X	X	X	X	X	X	X	X	X

9. Additional		1	External drainage
---------------	--	---	-------------------

10. Speed sensor		010	012	017	025	034	040	047	056	064	084	090	108	130
00	No speed sensor	X	X	X	X	X	X	X	X	X	X	X	X	X

X = Standard, preferred
O = Contact Sunfab

Motor SAM 010-130 DIN		010	012	017	025	034	040	047	056	064	084	090	108	130
Displacement	cm ³ /rev	9.6	12.6	17.0	25.4	34.2	41.2	47.1	56.7	63.5	83.6	90.7	108.0	130.0
Working pressure														
<i>max intermittent</i>	bar	400	400	400	400	400	400	400	400	400	400	400	400	330
<i>max continuous</i>		350	350	350	350	350	350	350	350	350	350	350	350	280
Revolutions														
<i>max intermittent</i>	rpm	3000	3000	3000	3000	3000	2500	2500	2500	2500	2000	2000	2000	2000
<i>max continuous</i>		2400	2400	2400	2400	2400	2000	2000	2000	2000	1600	1600	1600	1600
<i>min continuous</i>		300	300	300	300	300	300	300	300	300	300	300	300	300
Power														
<i>max intermittent</i>	kW	14	18	24	36	49	57	65	78	88	93	100	120	124
<i>max continuous</i>		11	14	19	29	39	46	52	62	70	74	81	96	99
Starting torque theoretical value	Nm/bar	0.15	0.20	0.27	0.40	0.54	0.66	0.75	0.89	1.0	1.33	1.44	1.71	2.06
Moment of inertia (x 10 ⁻³)	kg m ²	0.9	0.9	0.9	1.1	1.1	2.6	2.6	2.6	2.6	7.4	7.4	7.4	7.4
Max intermittent housing pressure	bar	5	5	5	5	5	5	5	5	5	5	5	5	5
Weight	kg	6.9	6.9	6.9	7.1	7.1	9.9	9.9	9.9	9.9	13.8	13.8	13.8	13.8

Intermittent operation refers to a max of 6 seconds per minute, representing e.g. peaks in rotational speed during unloading and acceleration.

General instructions

Shaft loads

The service life of the motor largely depends on the service life of the bearings. These are affected by the operating conditions such as speed, pressure, oil viscosity and degree of purification.

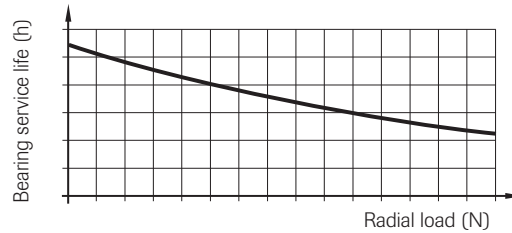
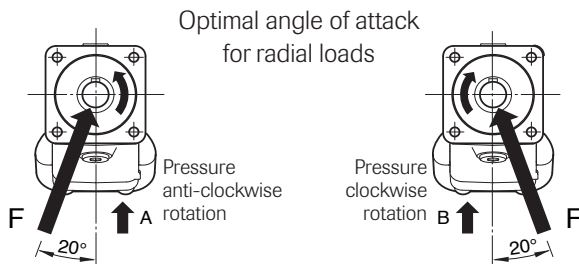

External loading of the shaft, its size, direction and location also affect the service life of the bearings.

If a calculation of bearing service life is required for special applications, contact Sunfab Hydraulics.

Installation

The motor housing is filled with oil to at least 50% of the volume before start up. The drainage hose is connected to the drainage outlet positioned highest on the motor. The other end is connected below the oil level in the oil tank.

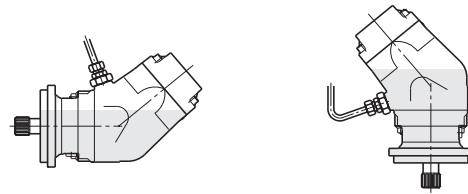

Hydraulic fluids

High performance oil meeting the specifications of ISO type HM, DIN 51524-2HLP or better must be used. Min. viscosity 10 cSt is required to guarantee lubrication. Ideal viscosity is 20 - 40 cSt.

Pipe dimensions

The recommended flow velocity in the pressure line is max 7 m/sec.

Filtering

Cleanliness ISO norm 4406, code 16/13 is recommended.

Useful formulaes

Required flow rate $Q = \frac{D \times n}{1000 \times \eta_v}$ litres/min.

Speed $n = \frac{Q \times 1000 \times \eta_v}{D}$ RPM

Torque $M = \frac{D \times \Delta p \times \eta_{hm}}{6.3}$ Nm

Power $P = \frac{Q \times \Delta p \times \eta_t}{60}$ kW

D = displacement, cm³/rev

n = revolutions, rev/min

P = power, kW

Q = flow, litre/min

η_v = volumetric efficiency

η_{hm} = hydromechanical efficiency

η_t = total efficiency = $\eta_v \times \eta_{hm}$

M = torque, Nm

Δp = pressure difference between inlet and outlet on the hydraulic motor, MPa

Dimensions SAM 010-034

Flange, shaft & connection cover

Millimeter (inch)

DL4 ISO 7653-D

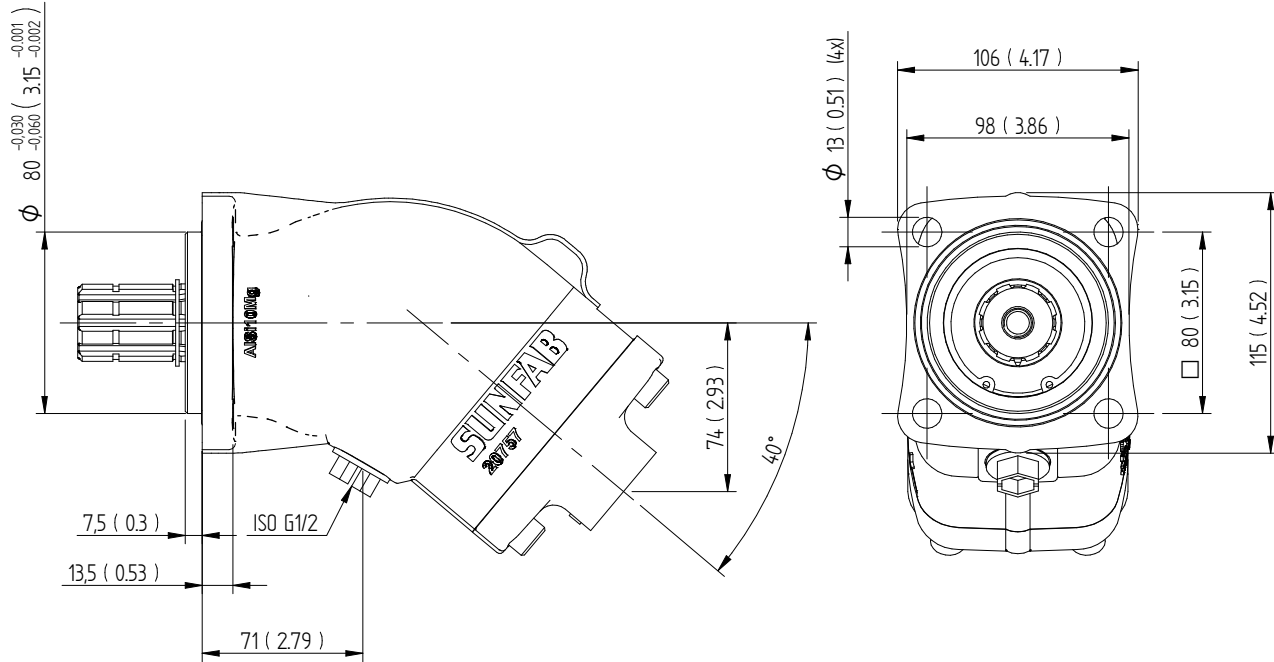

L35 DIN 5462 / ISO 14

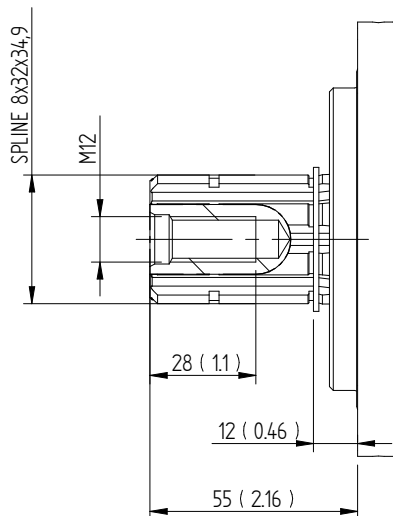

S3G

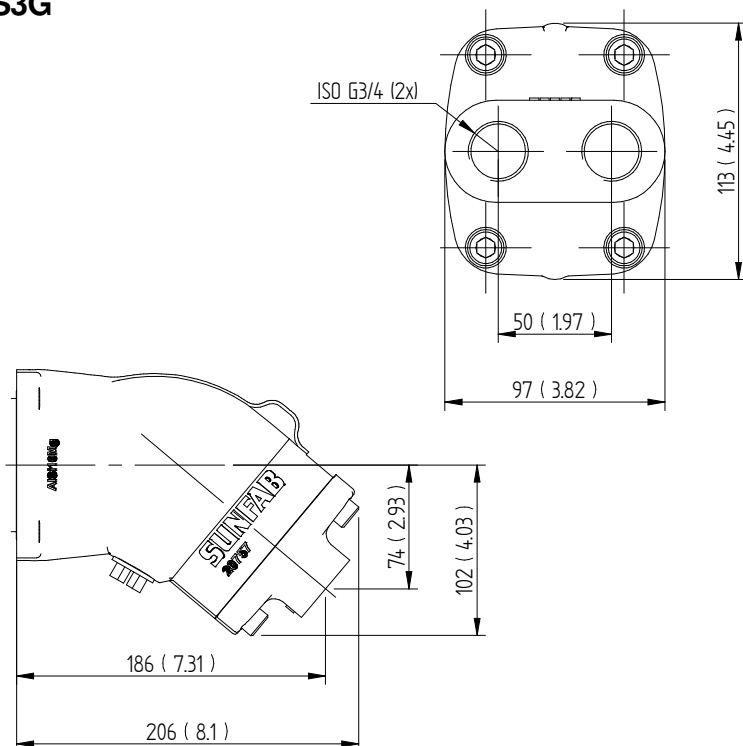

Dimensions SAM 040-064

Flange, shaft & connection cover

Millimeter (inch)

DL4 ISO 7653-D

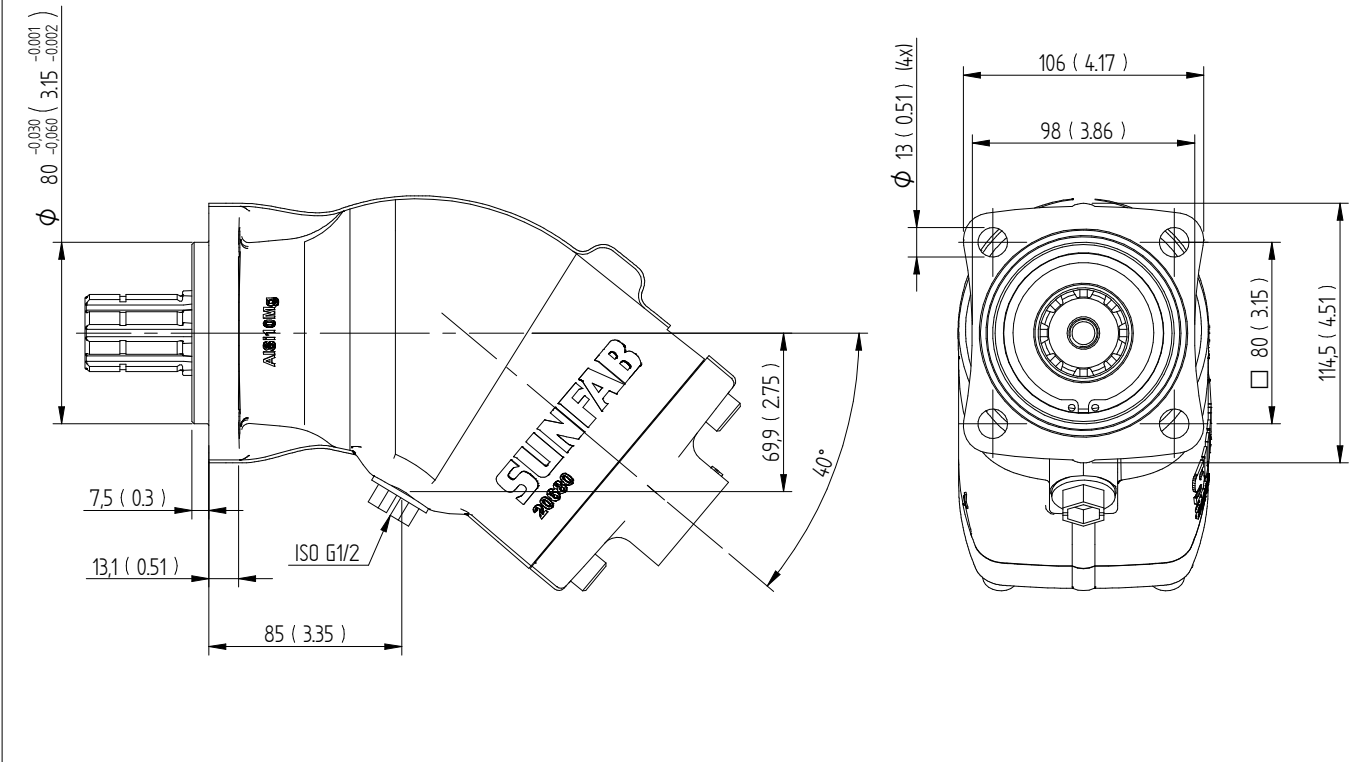

L35 DIN 5462 / ISO 14

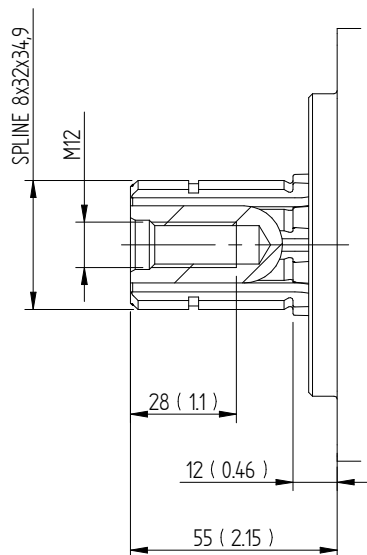

S3G

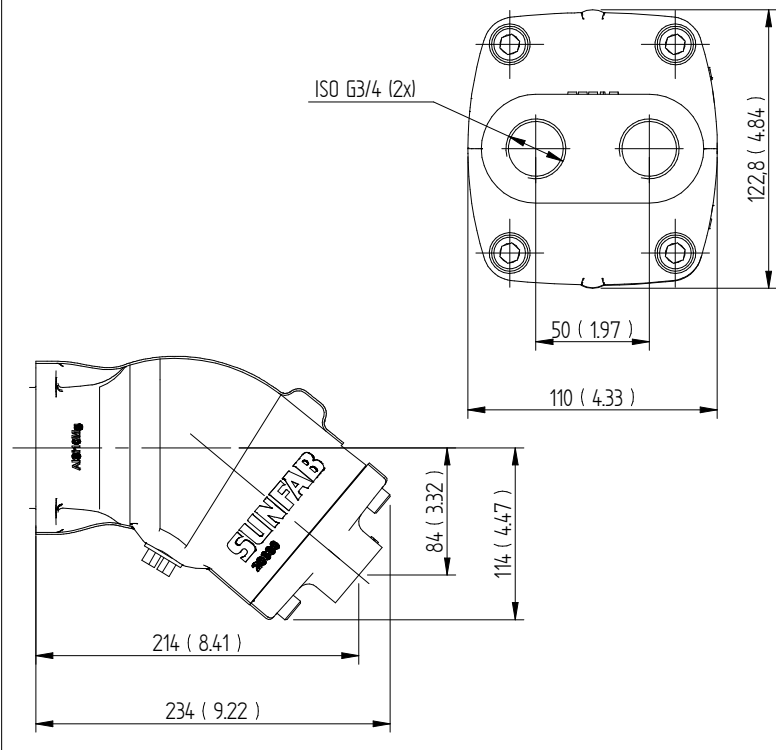

Dimensions SAM 084-130

Flange, shaft & connection cover

Millimeter (inch)

DL4 ISO 7653-D

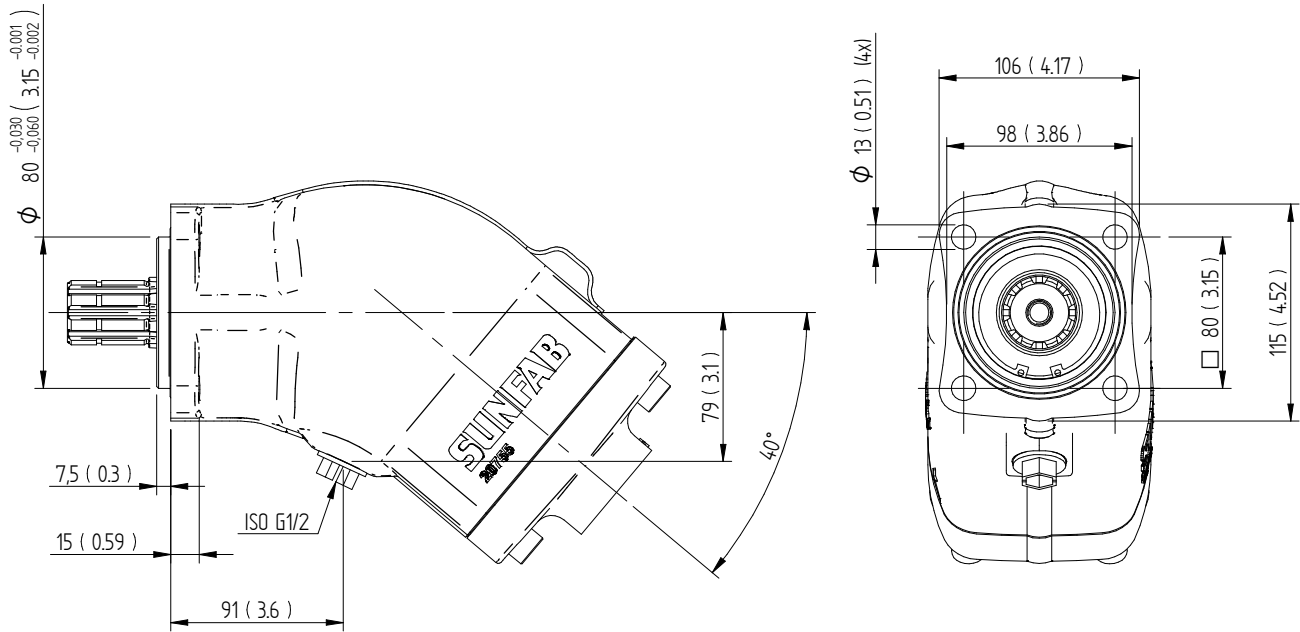

L35 DIN 5462 / ISO 14

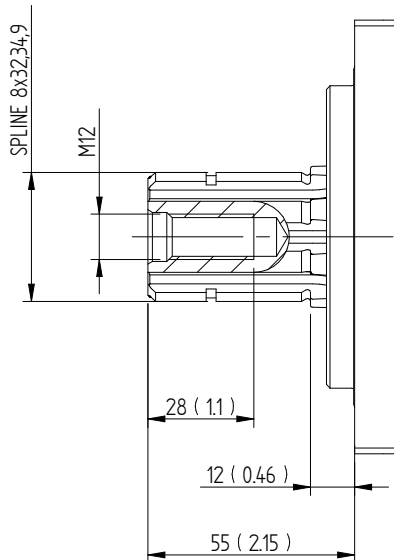

S3G

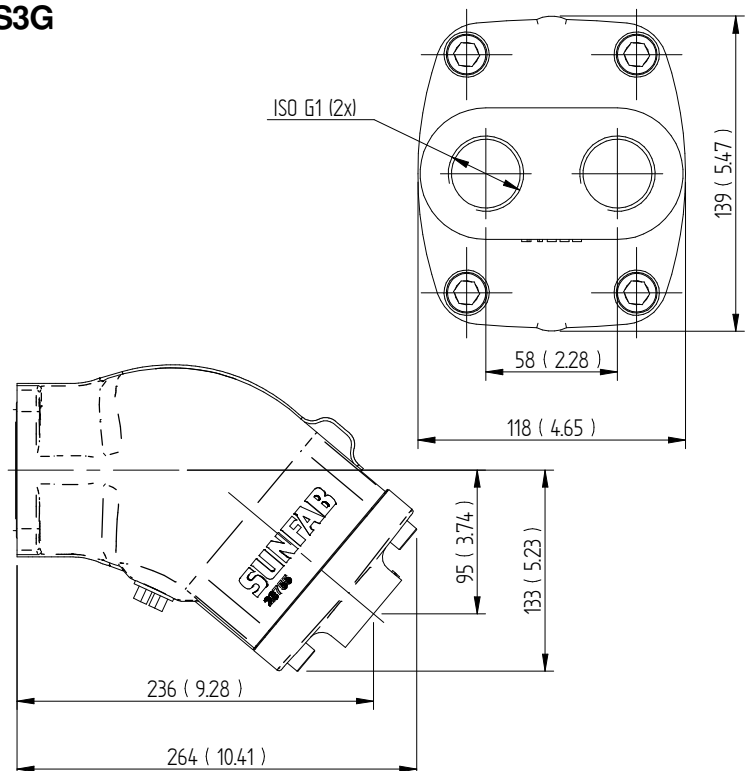



WARNING

When the motor is in use:

1. Do not touch the pressure pipe
2. Beware of rotating parts
3. The motor and pipes can reach high temperatures

*Sunfab reserves the right to make changes in design and dimensions without notice. Printing and typesetting errors reserved.
© Copyright 2015 Sunfab Hydraulics AB. All Rights Reserved.*