

Internal Gear Pumps

Series QX

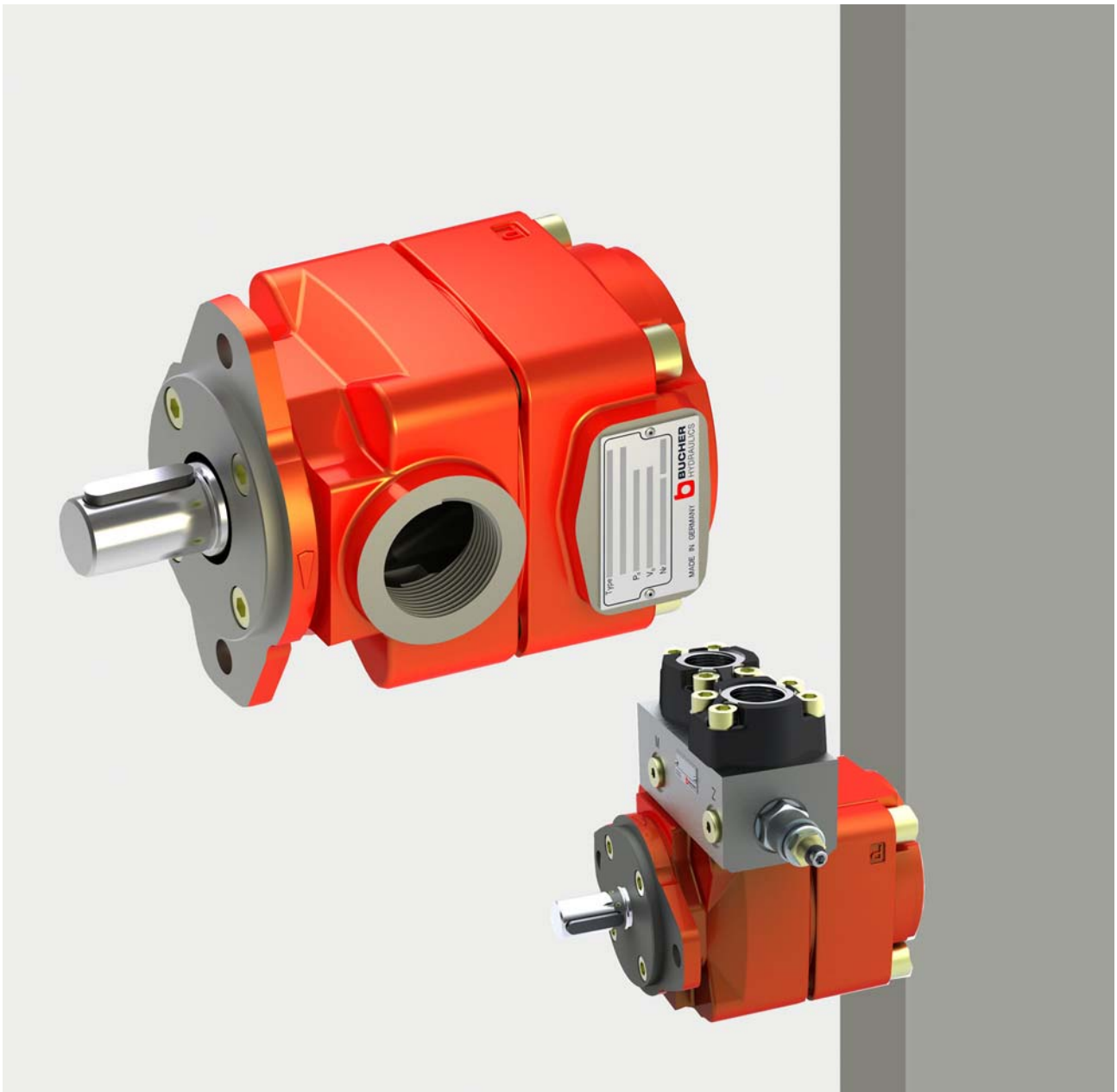

motion and progress

Contents

Page

1	General	5
	1.1 Product description	5
	1.2 Advantages	5
2	Technical data	5
	2.1 General (deviating values according manufacturer's specification)	5
	2.2 Main characteristics for pressure range 1	6
	2.3 Main characteristics for pressure range 2	7
	2.4 Main characteristics for pressure range 3	7
3	Performance graphs	8
	3.1 Noise level (Lp)	8
	3.2 Efficiency (η)	8
	3.3 Operation with variable-speed drives	9
4	Single pumps	10
	4.1 Dimensions (inch)	10
	4.2 Pressure range 1	11
	4.3 Pressure range 2	11
	4.4 Pressure range 3	12
	4.5 Ordering code for single pumps	12
	4.6 Standard configuration	12
	4.7 Options	12
5	Double pumps	13
	5.1 Selection table	13
	5.2 Dimensions (inch)	14
	5.3 Ordering code for double pumps	23
6	Triple pumps	24
	6.1 Selection table	24
	6.2 Ordering code for triple pumps	25
7	Low-flow capability pumps	26
	7.1 Generals	26
	7.2 Technical data	26
	7.3 Main characteristics	26
	7.4 Efficiency (η)	27
	7.5 Single pump	27
	7.6 QX24 pump combined also QX-pumps	28

8	Fluid cleanliness	29
9	Fluid cleanliness	29
10	Operational reliability	29
11	Note	29
12	Accessories	30
12.1	Bolt-on valves - SAE J518 code 61 / ISO 6162-1 pattern	30
12.2	Pipe flange - high pressure type	31
12.3	Low pressure type	31

1 General

1.1 Product description

The QX pumps are the 5th generation of Bucher internal gear pumps, which have proven themselves in thirty years of service around the world. Numerous improvements have been made to the straightforward and robust design.

Advances in the manufacturing process have made it possible without making higher demands on individual components to build pumps that are considerably lighter and more compact.

A new tooth profile, conceived and optimised with the help of CAE, has yielded another significant reduction in noise levels. Large sealing areas result in higher efficiencies.

The internal gear ring is supported by a hydrodynamic/ hydrostatic lubricating film, which allows operation at low viscosities or low and high speeds. QX pumps are therefore suitable for use with variable speed drives, where they can provide variable deliveries.

1.2 Advantages

- extremely long service life
- sound pressure level < 57 dB (A)
- volumetric efficiency up to 98%
- suitable for use with variable speed drivers
- can be used with fire-resistant fluids (HFB, HFC and HFD = QXV), fuels, biodegradable and low-viscosity fluids
- certifications by ATEX 2, ABS, DNV, GL, LR, NK, ...
- low flow and pressure pulsations

2 Technical data

2.1 General (deviating values according manufacturer's specification)

Installation attitude	unrestricted
Mounting method (standard)	oval 2-hole flange to ISO 3019/1 (SAE): QX 3 to 6 oval 2-hole flange to ISO 3019/2 (metric) QX 2 and 8
Direction of rotation	CW, alternatively CCW (but not reversible)
Pump drive method	in-line, through a flexible coupling
Volumetric efficiency η_v	up to 98%
Fluids	HLP mineral oils to DIN 51524, Part 2 HFC fluids to VDMA 24317
Minimum fluid cleanliness	NAS 1638, Class 9 or ISO 4406, code 20/18/15 (see page 29)
Operating viscosity Starting viscosity	10 to 100 mm ² /s 10 to 300 mm ² /s (higher values, contact Bucher Hydraulics)
Fluid temperature range	HLP-mineral oils -20 °C min. / - 80 °C max. (Considering viscosity field) HFC 50 °C max.
Inlet pressure maximum minimum	1.5 bar absolute (without external drain connection) 0.5 to 0.98 bar absolute (dependent on pump frame size and speed, see example in section 3.3.2)
Startup against pressure	maximum 20 bar (higher values, contact Bucher Hydraulics)



IMPORTANT. The main characteristics are valid for hydraulic oils DIN 51524 with a viscosity of 20 to 50 mm²/s. The operating pressure at the pump outlet side is specified also for fire-resistant and environmentally-friendly fluids (HFC).

2.2 Main characteristics for pressure range 1

Displacement	Flow rate at speed	Maximum speed	Code	operating pressure at the pump outlet side				Torque	Input power
				continuous [bar]		intermittent [bar] ²⁾			
[cm ³ /rev] ¹⁾	[l/min]	[rpm]		Mineral oil	HFC	Mineral oil	HFC	[Nm] ³⁾	[kW] ⁴⁾
effektiv	1450 min ⁻¹ p = 0 bar								
10,3	14,9	3600	QX21-010	160	130	210	180	26	4,0
12,6	18,3	3600	QX21-012	125	100	160	135	25	3,8
15,9	23,0	3600	QX21-016	100	80	125	100	25	3,9
20,0	29,0	3000	QX31-020	160	130	210	180	51	7,7
25,3	36,7	3000	QX31-025	125	100	160	135	50	7,7
31,2	45,2	3000	QX31-032	100	80	125	100	50	7,5
40,7	59,0	3000	QX41-040	160	130	210	180	104	15,7
50,3	72,9	2600	QX41-050	125	100	160	135	100	15,2
64,7	93,8	2300	QX41-063	100	80	125	100	103	15,6
78,6	114	2300	QX51-080	160	130	210	180	200	30,4
101,1	146	2100	QX51-100	125	100	160	135	201	30,5
127,3	184	1800 ⁵⁾	QX51-125	100	80	125	100	203	30,8
160,5	232	1800 ⁶⁾	QX61-160	160	130	210	180	409	62,0
202,1	293	1800 ⁶⁾	QX61-200	125	100	160	135	402	61,0
249,7	362	1800 ⁶⁾	QX61-250	100	80	125	100	397	60,4
326,0	472	1750 ⁶⁾	QX81-315	160	130	210	180	830	126,0
402,6	583	1750 ⁶⁾	QX81-400	125	100	160	135	801	121,6
498,5	722	1500 ⁶⁾	QX81-500	100	80	125	100	793	120,5

2.2.1 Suction arrangements for pump types QX61 and QX81



Minimum inlet pressure is 0.95 bar absolute with viscosity 10... 100 mm²/s (other values, contact Bucher Hydraulics)

	Speed 1500 rpm Suction height		Speed 1800 rpm Suction height	
	up to 150 mm	over 150 mm	up to 150 mm	over 150 mm
QX61-160	I	I	I	II
QX61-200	I	I	I	II
QX61-250	I	II	II	II
QX81-315	I	II	II	II
QX81-400	II	II	II	-
QX81-500	II	II	-	-

I = standard pump with one suction port

II = model with two suction ports

All pump types coded II can be used without the second suction port up to 1200 rpm

2.3 Main characteristics for pressure range 2

Displacement	Flow rate at speed	Maximum speed	Code	operating pressure at the pump outlet side				Torque	Input power
				continuous [bar]		intermittent [bar] ²⁾			
effektiv	1450 min ⁻¹ p = 0 bar			Mineral oil	HFC	Mineral oil	HFC	[Nm] ³⁾	[kW] ⁴⁾
[cm ³ /rev] ¹⁾	[l/min]	[rpm]							
5,1 6,3 8,0	7,4 9,1 11,5	3600	QX22-005 QX22-006 QX22-008	210	180	250	210	17 21 27	2,6 3,2 4,0
10,0 12,6 15,6	14,5 18,3 22,6	3400	QX32-010 QX32-012 QX32-016	210	180	250	210	34 42 52	5,1 6,4 7,9
20,4 25,1 32,4	29,5 36,4 46,8	3200	QX42-020 QX42-025 QX42-032	210	180	250	210	68 84 108	10,4 12,7 16,5
39,3 50,6 63,7	56,9 73,2 92,1	2800	QX52-040 QX52-050 QX52-063	210	180	250	210	132 170 213	19,9 25,7 32,3
80,2 101,0 124,8	116 146 181	2500 ⁷⁾ 2300 ⁷⁾ 2000 ⁷⁾	QX62-080 QX62-100 QX62-125	210	180	250	210	268 338 417	40,7 51,2 63,4
163,0 201,3 249,2	236 291 361	1800 ⁷⁾ 1750 ⁷⁾ 1500 ⁷⁾	QX82-160 QX82-200 QX82-250	210	180	250	210	544 672 833	82,7 102,1 126,5

2.4 Main characteristics for pressure range 3

Displacement	Flow rate at speed	Maximum speed	Code	operating pressure at the pump outlet side				Torque	Input power
				continuous [bar]		intermittent [bar] ²⁾			
effektiv	1450 min ⁻¹ p = 0 bar			Mineral oil	HFC	Mineral oil	HFC	[Nm] ³⁾	[kW] ⁴⁾
[cm ³ /rev] ¹⁾	[l/min]	[rpm]							
5,1 6,3 8,0	7,4 9,1 11,5	3600	QX23-005 QX23-006 QX23-008	320	280	400	350	26 32 41	4,0 4,9 6,2
10,0 12,6 15,6	14,5 18,3 22,6	3400	QX33-010 QX33-012 QX33-016	320	280	400	350	51 64 80	7,7 9,7 12,1
20,4 25,1 32,4	29,5 36,4 46,8	3200	QX43-020 QX43-025 QX43-032	320	280	400	350	104 128 165	15,8 19,4 25,0
39,3 50,6 63,7	56,9 73,2 92,1	2800	QX53-040 QX53-050 QX53-063	320	280	400	350	200 258 321	30,4 39,1 49,3
80,2 101,0 124,8	116 146 181	2500 ⁷⁾ 2300 ⁷⁾ 2000 ⁷⁾	QX63-080 QX63-100 QX63-125	320	280	400	350	409 514 636	62,0 78,1 96,5
163,0 201,3 249,2	236 291 361	1800 ⁷⁾ 1750 ⁷⁾ 1500 ⁷⁾	QX83-160 QX83-200 QX83-250	320	280	400	350	830 1025 1270	126,0 155,7 192,7

1) Due to manufacturing tolerances, there may be slight variations in the displacement.

2) maximum 20 second and not more than 10% of the duty cycle

3) theoretical value at the max. permitted continuous pressure for mineral oil

4) theoretical value at the max. permitted continuous pressures for mineral oil at n = 1450 rpm

5) for speeds > 1450 rpm, the min. permissible inlet pressure is 0.95 bar absolute. For HFC application a second suction port may be required

6) max. speed only possible with second suction port, see section 2.2.1

7) for speeds > 1450 rpm, the min. permissible inlet pressure is 0.95 bar absolute.

3 Performance graphs



The performance graphs shown are valid for the specified pump models.
For other pump sizes, contact Bucher Hydraulics.

3.1 Noise level (L_p)

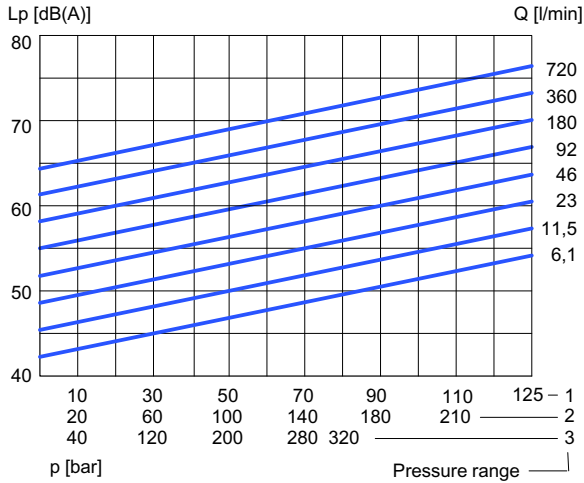

measured to DIN 45635, Part 26, in Stuttgart University's low-echo noise measurement chamber;
measurement distance 1 m; speed $n = 1500$ rpm; viscosity = $42 \text{ mm}^2/\text{s}$

3.2 Efficiency (η)

measured at speed 1450 rpm, viscosity $42 \text{ mm}^2/\text{s}$

3.2.1 Pressure range 1

Volumetric efficiency

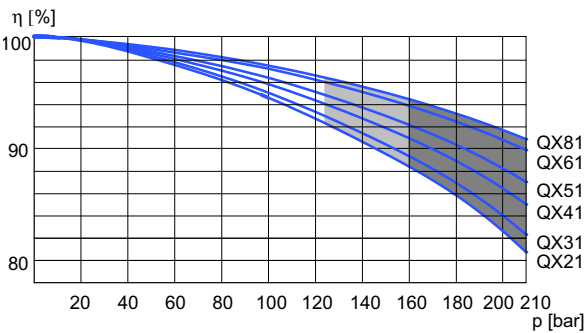

Hydromechanical efficiency

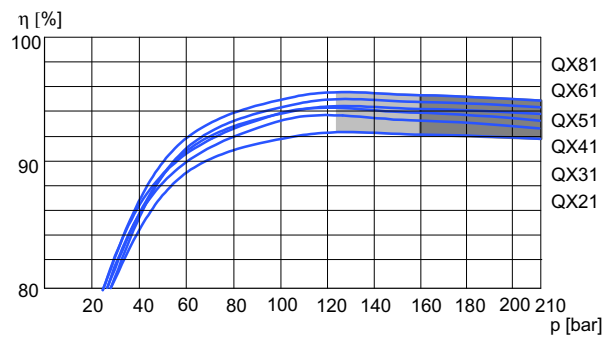

Intermitted operating pressure as a function of displacement (see chapter 2.2)

3.2.2 Pressure range 2

Volumetric efficiency

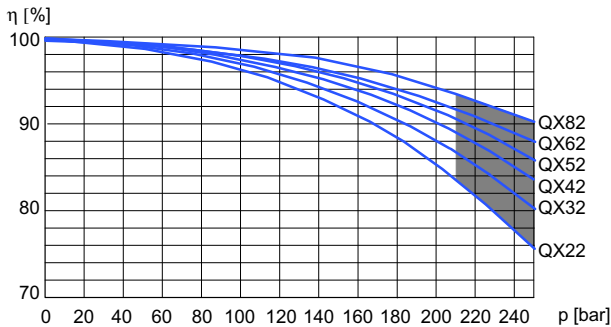

Hydromechanical efficiency

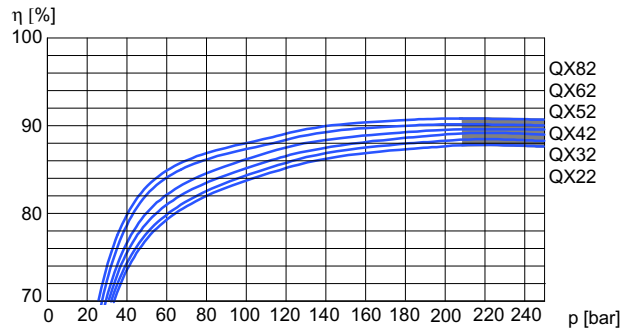

Intermitted operating pressure

3.2.3 Pressure range 3

Volumetric efficiency

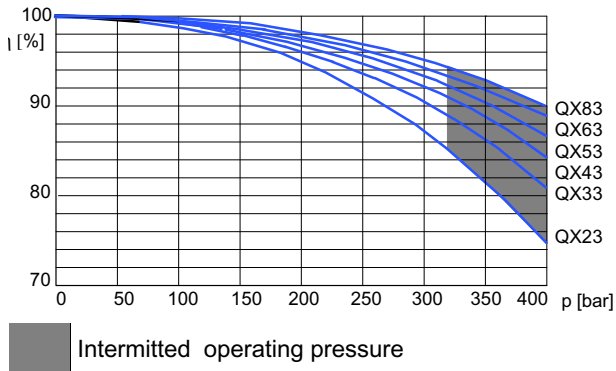

Hydromechanical efficiency

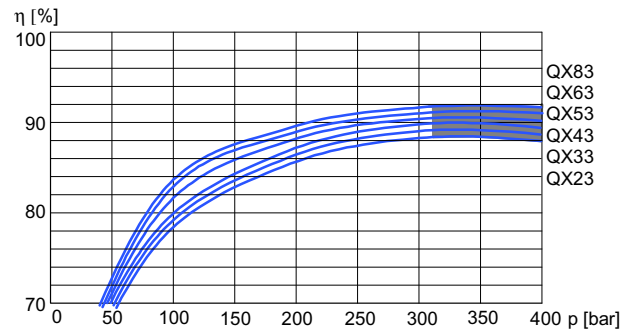

3.3 Operation with variable-speed drives



IMPORTANT: The following main characteristics are to be understood as examples only. They are valid only for the specified pump models and parameters. We would be very happy to advise you on the layout of your drive. QX pumps with variable-speed drive are all contains external drain port.

3.3.1 Typical loading cycle for a QX pump with variable-speed drive

Pump QX53-063 with viscosity 20 mm²/s

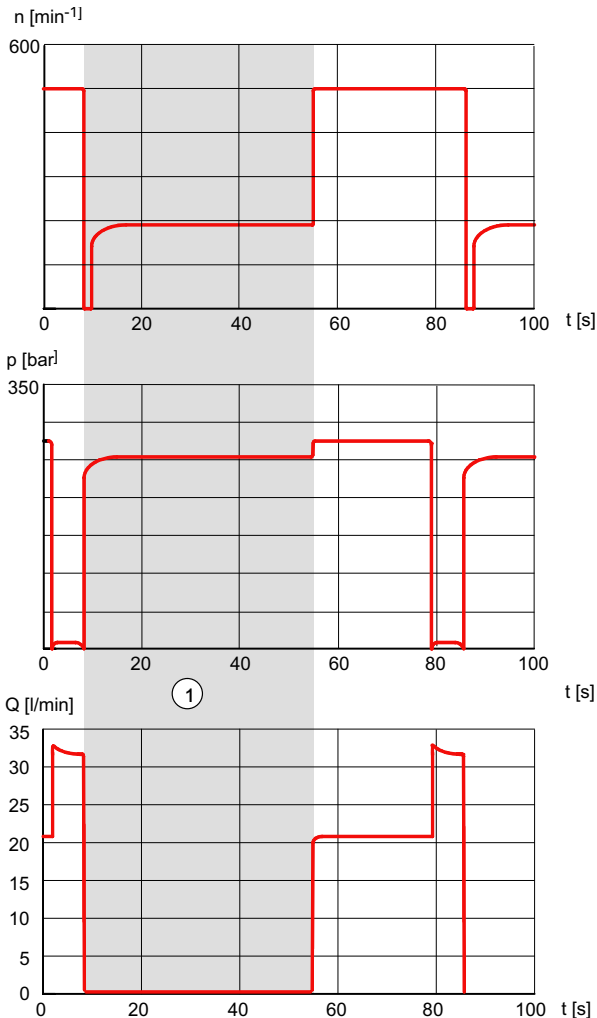

3.3.2 Minimum speed as a function of pressure

Pump QX53-063 measured: with viscosity 42 mm²/s

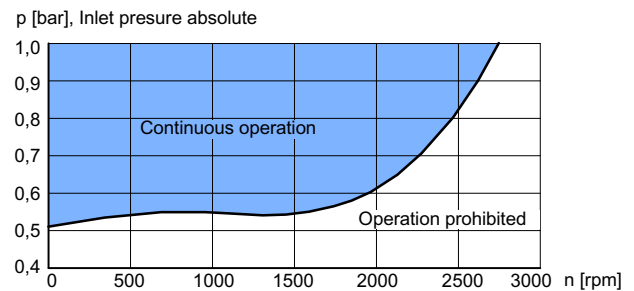

3.3.3 Minimum pressure at suction port as a function of Speed

Pump QX53-063 measured with viscosity 42 mm²/s

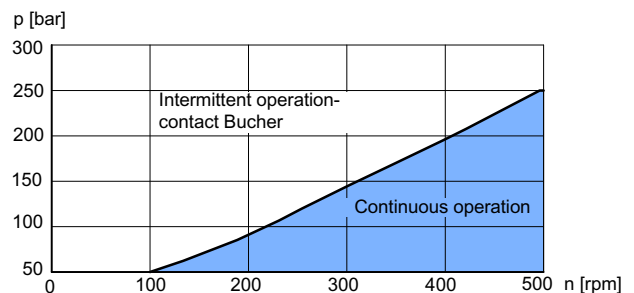

1 Pressure-holding operation
Q = 0 l/min for up to 60 s

4 Single pumps

4.1 Dimensions

Frame size		2			3			4			5			6			8		
Pressure range		1	2	3	1	2	3	1	2	3	1	2	3	1	2	3	1	2	3
Suction port: to SAE J518 ¹⁾	S	G1 ³⁾ thread			G1 1/4 ³⁾ thread			1 1/2"			2"			2 1/2"			3"		
Pressure port: to SAE J518 ¹⁾	P	G1/2 ^{3) 4)} thread			G3/4 ^{3) 4)} thread			1"			1 1/4"			1 1/2"			2"		
External drain port (option 06)	①	G1/4"			G1/4"			G1/4"			G1/4"			G3/8 "			G1/2"		
Mounting: oval 2-hole- flange to ISO 3019/1 (SAE) ISO 3019/2 (metric)	A	118			132			170			212			267			330		
	B (SAE)	-			106			146			181			229			-		
	B (Metr.)	100			109			140			180			224			280		
	C	9			11			14			18			22			26		
	N (SAE)	-			82,55 - 0,05			101,6 - 0,05			127 - 0,05			152,4 - 0,05			-		
	N (Metr.)	63 h8			80 h8			100 h8			125 h8			160 h8			200 h8		
	O	8,5			8,5			10,5			12,5			16,5			20		
V	6			6			7			7			7			9			
4-hole flange ISO 3019/2	X (Metr.)	9			9			12			14			18			22		
	Y (Metr.)	85			103			125			160			200			250		
Shaft end: parallel, to ISO/R775 ²⁾	D	20 j6			25 j6			32 j6			40 j6			50 j6			63 j6		
	E	36			42			58			82			82			105		
	F	6			8			10			12			14			18		
	G	22,5			28			35			43			53,5			67		
	I	45			50			68			92			92			117		
Housing	K	37,5			44			52,5			60,5			74			90		
	L	136	118	153	164	144	189	202	176	232	242	210	280	288	248	338	361	331	446
	M	-	55	90	-	69,5	114	-	87	143	-	102	172	-	119	209	-	151	266
	T	85			107			133			177			214	220	220	273	275	275
	Z	50			60			62,5			78			97,5			125		
Weight	kg	5	5	6,5	10	9,5	12,5	18	17	22	33	31	40	64	60	76	130	120	160

1) pipe flange dimensions, SAE J518 code 61 / ISO 6162-1
high pressure type up to 420 bar (see section 10.2)
low pressure type for up to 16 bar (see section 10.3)

2) for other shaft ends, contact Bucher Hydraulics
3) threaded port to DIN 3852, Part 2

4) pressure port to SAE J518 code 61 / ISO 6162-1 can be supplied for pressure ranges 2 and 3

4.2 Pressure range 1

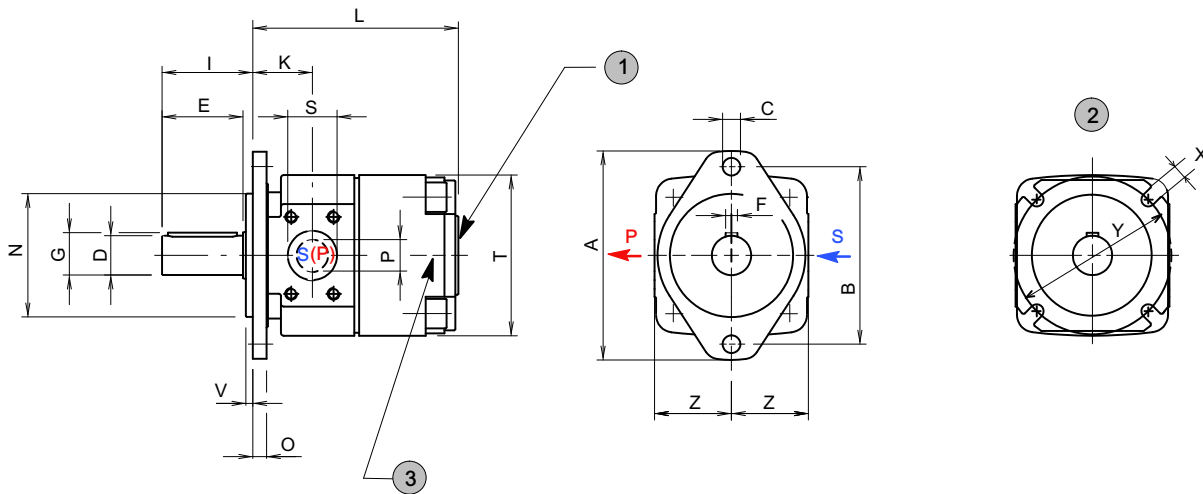

1 external drain port - see special feature 06

2 Special model: 4-hole flange ISO 3019/2

3 Depending on operating conditions, a second suction port may be required on QX61 (SAE 2") and QX81 (SAE 2 1/2") - see section 2.2.1

4.3 Pressure range 2

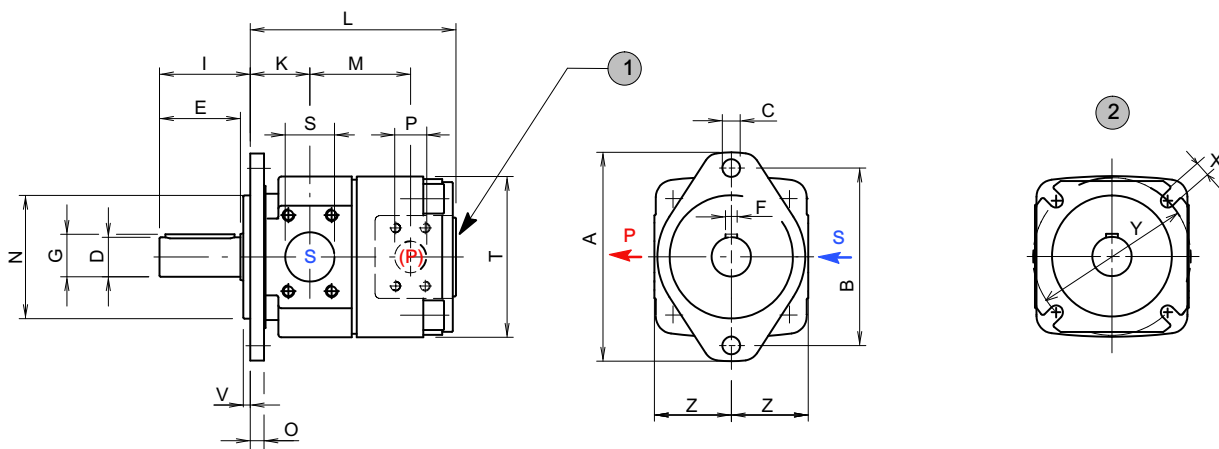

1 external drain port - see special feature 06

2 Special model: 4-hole flange ISO 3019/2

4.4 Pressure range 3

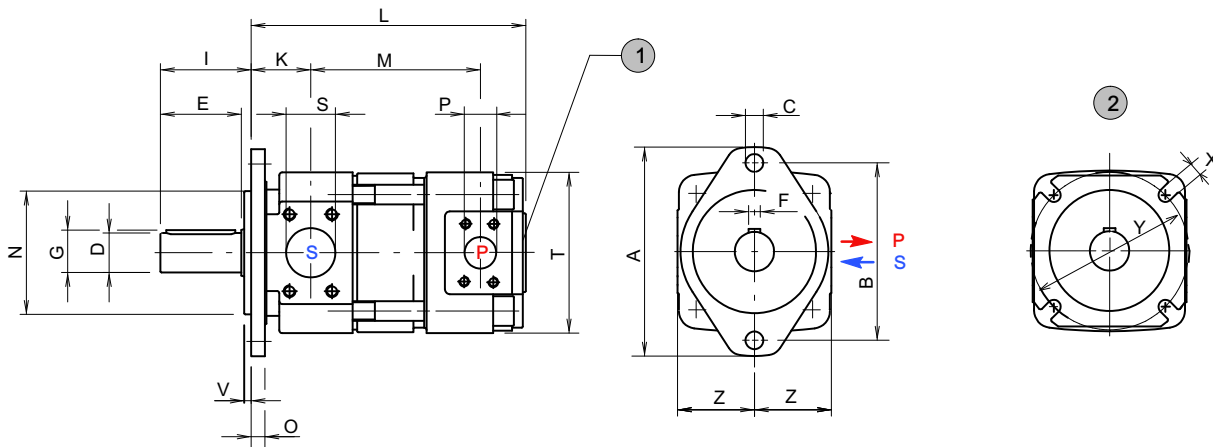

1 external drain port - see special feature 06

2 Special model: 4-hole flange ISO 3019/2

4.5 Ordering code for single pumps

Series	= QX	Q	X	5	3	-	0	4	0	R	*	*
Frame size	= 2 / 3 / 4 / 5 / 6 / 8											
Pressure range	= 1 / 2 / 3											
Displacement in cm ³ /rev	= 005 - 500											
Rotation (viewed from shaft end)	right (CW) = R (Standard) left (CCW) = L											
Option	(see section 4.7 for a selection)											

Ordering example:

Required: single pump
 Displacement: 40 cm³/rev
 Continuous pressure: 300 bar
 for use with mineral oil
 Ordering code: QX53-040R

4.6 Standard configuration

- direction of rotation - right (CW)
- 2-hole mounting flange to ISO 3019/1 (SAE): sizes QX 3-6
- 2-hole mounting flange to ISO 3019/2 (metr.): sizes QX 2+8
- Nitrile seals
- parallel shaft end to ISO/R775

4.7 Options

- 06 = external drain port in the pump rear cover
 QX 2-5 G1/4"
 QX 6 G3/8"
 QX 8 G1/2"
- 09 = Viton seals
- 12 = 2-hole mounting flange to ISO 3019/2 (metric): size QX3-6
- 29 = for HFB and HFC fluids, frame sizes 2 to 8
- 66 = 4-hole mounting flange to ISO 3019/2 (metric)
- 83 = second suction port on:
 QX61 = SAE 2"
 QX81 = SAE 2 1/2"
- 86 = for HFB and HFC fluids, frame sizes 6 and 8
- 117 = pressure port to SAE J518 code 61 / ISO 6162-1 can be supplied for frame size 2 + 3 with pressure ranges 2 + 3

5 Double pumps

QX double pumps consist of two single pumps mounted on a common drive shaft. Hydraulically, the two pumps operate independently of one another but they share a common suction port in the pump's centre section. The larger pump of the combination is situated at the shaft end (the drive side) and is referred to as Pump I. With equal frame sizes, the pump with the larger displacement is situated at the drive side.

Double pumps can be combined as shown in the following table. If a letter is shown at the intersection point of the two pumps, the letter identifies the page in section 5.2 that contains the relevant dimensional drawing. If there is no letter at the intersection point, then that pump combination is not possible.

5.1 Selection table

Pump 1		Pump 2																Maximum permissible drive shaft torque (Nm)			
		Displacement in cm ³ /rev																			
		5/6/8		10/12/16		20/25/32		40/50/63		80/100/125		160/200/250		315	400	500					
Displacement in cm ³ /rev		Maximum intermittent pressure in bar																			
		250	400	125 160 210	250	400	125 160 210	250	400	125 160 210	250	400	125 160 210	250	400	125 160 210					
		QX22..	QX23..	QX21..	QX32..	QX33..	QX31..	QX42..	QX43..	QX41..	QX52..	QX53..	QX51..	QX62..	QX63..	QX61..	QX82..	QX83..	QX81..		
Pump 1	5/6/8	250	QX22..	E																65	
		400	QX23..	H	I																
	10/12/16	125/160 210	QX21..	B	C	A															130
		250	QX32..	E	F	D	E														
	20/25/32	400	QX33..	H	I	G	H	I													260
		125/160 210	QX31..	B	C	A	B	C	A												
	40/50/63	250	QX42..	E	F	D	E	F	D	E											520
		400	QX43..	H	I	G	H	I	G	H	I										
	80/100/125	125/160 210	QX41..	B	C	A	B	C	A	B	C	A									1050
		250	QX52..	E	F	D	E	F	D	E	F	D	E								
	160/200/250	400	QX53..	H	I	G	H	I	G	H	I	G	H	I							2100
		125/160 210	QX51..	B	C	A	B	C	A	B	C	A	B	C	A						
	315 400 500	250	QX62..				E	F	D	E	F	D	E	F	D	E					2100
		400	QX63..				H	I	G	H	I	G	H	I	G	H	I				
		125/160 210	QX61..				B	C	A	B	C	A	B	C	A	B	C	A			2100
		250	QX82..							E	F	D	E	F	D	E	F	D	E		
	400	QX83..							H	I	G	H	I	G	H	I	G	H	I		
	125/160 210	QX81..							B	C	A	B	C	A	B	C	A	B	C	A	

5.2 Dimensions

A Double pumps QX.1/.1

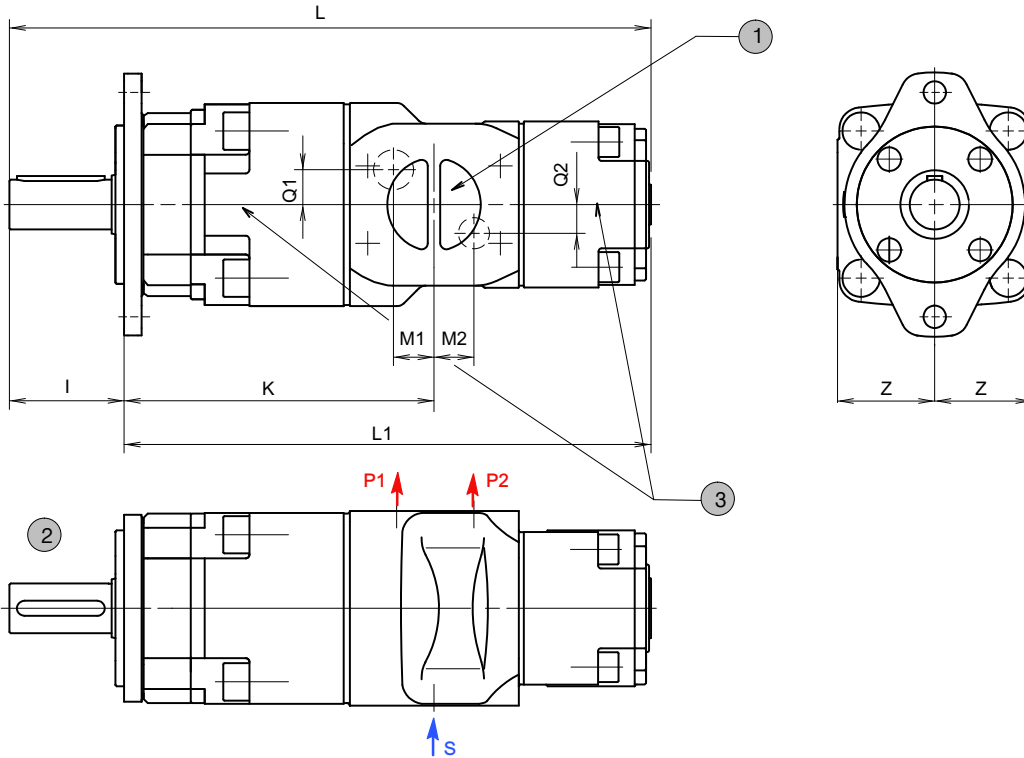

1	S = common suction port
2	shaft and mounting dimensions see section 4

3	depending on operating conditions, a second suction port may be required - see section 2.2.1, QX61 SAE 2", QX81 SAE 2 1/2"
---	--

Typ	L	L1	K	M1	M2	Q1	Q2	I	Z	S	P1	P2
QX21/21	296	251	141	18	18	-	-	45	50	G 1 1/4" ¹⁾	G 1/2" ^{1) 2)}	G 1/2" ^{1) 2)}
QX31/21	343	293	171	26	30	-	-	50	60	G 1 1/2" ¹⁾	G 3/4" ^{1) 2)}	G 3/4" ^{1) 2)}
QX31/31	358	308			26							G 1/2" ^{1) 2)}
QX41/21	396	328	201	19	35	15	15	68	63	SAE 2"	SAE 1"	G 1/2" ^{1) 2)}
QX41/31	411	343			33							G 3/4" ^{1) 2)}
QX41/41	449	381	208	26	26	23	23					1" SAE
QX51/21	468	376	241	23	43	15	-	92	78	SAE 2 1/2"	SAE 1 1/4"	G 1/2" ^{1) 2)}
QX51/31	483	391			39							G 3/4" ^{1) 2)}
QX51/41	521	429	249	30	32	28	23	92	98	SAE 3"	SAE 1 1/2"	SAE 1"
QX51/51	547	455			30							SAE 1 1/4"
QX61/31	541	449	287	24	47	17	14	92	98	SAE 3 1/2"	SAE 1 1/2"	G 3/4" ^{1) 2)}
QX61/41	564	472			27							SAE 1"
QX61/51	601	509	292	32	40	35	28	92	98	SAE 3 1/2"	SAE 1 1/2"	SAE 1 1/4"
QX61/61	628	536			32							SAE 1 1/2"
QX81/41	679	562	359	35	51	25	25	117	125	SAE 4"	SAE 2"	SAE 1"
QX81/51	705	588			47							30
QX81/61	732	615			45	35	SAE 1 1/2"					
QX81/81	774	657			38	40	SAE 2"					

1) threaded port to DIN 3852, Part 2

2) pressure port to SAE J518 code 61 / ISO 6162-1 can be supplied for pressure ranges 2 and 3

B Double pumps QX.1/2

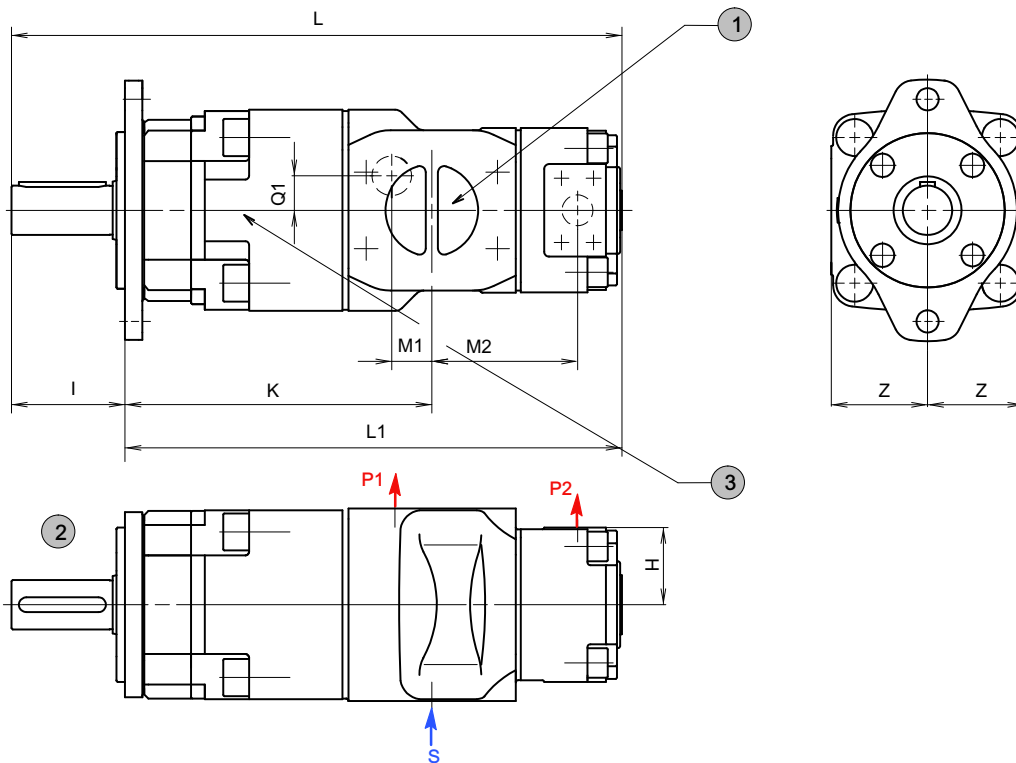

- | | |
|---|---|
| 1 | S = common suction port |
| 2 | shaft and mounting dimensions see section 4 |

- | | |
|---|--|
| 3 | depending on operating conditions, a second suction port may be required - see section 2.2.1, QX61 SAE 2", QX81 SAE 2 1/2" |
|---|--|

Typ	L	L1	K	M1	M2	Q1	I	Z	H	S	P1	P2
QX21/22	278	233	141	18	67	-	45	50	50	G 1 1/4" ¹⁾	G 1/2" ^{1) 2)}	G 1/2" ^{1) 2)}
QX31/22	325	275	171	26	79		50	60	60	G 1 1/2" ¹⁾	G 3/4" ^{1) 2)}	
QX31/32	338	288		87	15							68
QX41/22	378	310	201	19	84	15	68	63	50	SAE 2"	SAE 1"	G 1/2" ^{1) 2)}
QX41/32	391	323		92	23							111
QX41/42	423	355	208	26	111	23	92	78	50	SAE 2 1/2"	SAE 1 1/4"	G 1/2" ^{1) 2)}
QX51/22	450	358	241	23	92	15						60
QX51/32	463	371		100	28	118	28	92	78	63	SAE 3"	SAE 1 1/4"
QX51/42	495	403	127	17	112	17	92					
QX51/52	515	423	249	30	127	28		92	98	78	SAE 3"	SAE 1 1/2"
QX61/32	521	429	287	24	112	17	92					
QX61/42	538	446		27	123	26		92	98	63	SAE 3 1/2"	SAE 1 1/2"
QX61/52	569	477	292	32	137	35	92					
QX61/62	588	496		32	149	35		92	98	98	SAE 3 1/2"	SAE 1 1/2"
QX81/42	653	536	359	35	141	25	117					
QX81/52	673	556			150	25		117	125	78	SAE 4"	SAE 2"
QX81/62	692	575		38	162	40	117					
QX81/82	724	607			179	40		125	125	SAE 4"	SAE 2"	

1) threaded port to DIN 3852, Part 2

2) pressure port to SAE J518 code 61 / ISO 6162-1 can be supplied for pressure ranges 2 and 3

C Double pumps QX.1/3

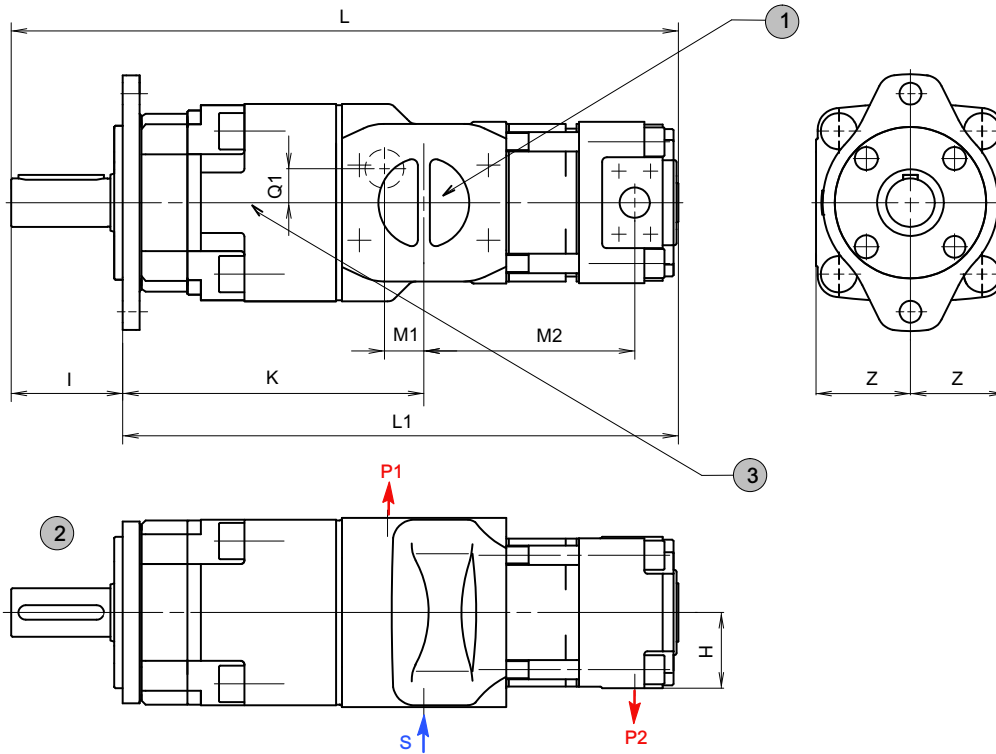

1	S = common suction port
2	shaft and mounting dimensions see section 4

3	depending on operating conditions, a second suction port may be required - see section 2.2.1, QX61 SAE 2", QX81 SAE 2 1/2"
---	--

Typ	L	L1	K	M1	M2	Q1	I	Z	H	S	P1	P2			
QX21/23	313	268	141	18	102	-	45	50	50	G 1 1/4" ¹⁾	G 1/2" ^{1) 2)}	G 1/2" ^{1) 2)}			
QX31/23	360	310	171	26	114		50	60	60	G 1 1/2" ¹⁾	G 3/4" ^{1) 2)}		G 3/4" ^{1) 2)}		
QX31/33	383	333			132	15	68	63	63	50	SAE 2"	SAE 1"	G 3/4" ^{1) 2)}		
QX41/23	413	345	119	60	SAE 1"										
QX41/33	436	368	137	63	SAE 1"										
QX41/43	479	411	208	26	167	23	92	78	50	SAE 2 1/2"	SAE 1 1/4"	G 1/2" ^{1) 2)}			
QX51/23	485	393	241	23	127	15						60	G 3/4" ^{1) 2)}		
QX51/33	508	416			145	28						78	63	SAE 1"	
QX51/43	551	459	249	30	174	17						92	98	60	SAE 3"
QX51/53	585	493			197		26	78	SAE 1 1/4"						
QX61/33	566	474	287	24	157	17	92	98	60	SAE 3 1/2"	SAE 1 1/2"	G 3/4" ^{1) 2)}			
QX61/43	594	502			27							179	26	63	SAE 1"
QX61/53	637	545			207							207	35	78	SAE 1 1/4"
QX61/63	678	586	292	32	239	25	117	125	98	SAE 3 1/2"	SAE 2"	SAE 1 1/2"			
QX81/43	709	592			197							197	63	SAE 1"	
QX81/53	743	626	359	35	220	25	117	125	78	SAE 2"	SAE 2"	SAE 1 1/4"			
QX81/63	782	665			252							252	98	SAE 1 1/2"	
QX81/83	839	722	38	38	294	40	117	125	125	SAE 4"	SAE 2"	SAE 2"			

1) threaded port to DIN 3852, Part 2

2) pressure port to SAE J518 code 61 / ISO 6162-1 can be supplied for pressure ranges 2 and 3

D Double pumps QX.2/1.1

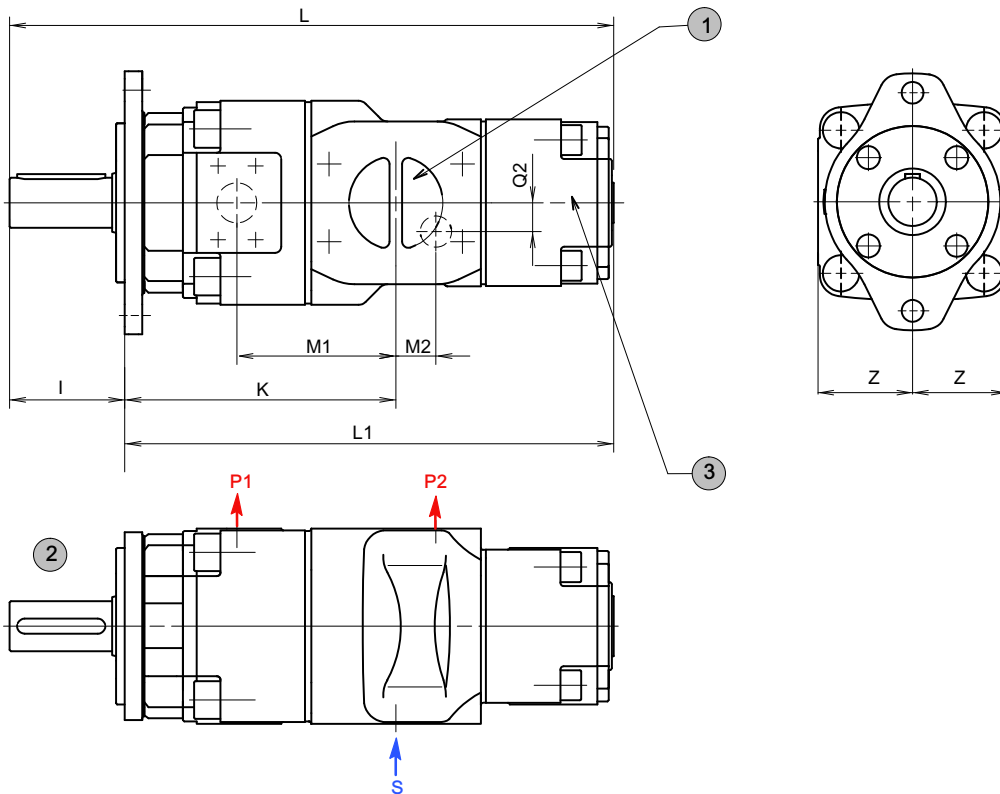

1	S = common suction port
2	shaft and mounting dimensions see section 4

3	depending on operating conditions, a second suction port may be required - see section 2.2.1, QX61 SAE 2"
---	---

Typ	L	L1	K	M1	M2	Q2	I	Z	S	P1	P2
QX32/21	323	273	151	87	30	-	50	60	G 1 1/2" ¹⁾	G 3/4" ^{1) 2)}	G 1/2" ^{1) 2)}
QX42/21	370	302	175	103	35	-	68	63	SAE 2"	SAE 1"	G 3/4" ^{1) 2)}
QX42/31	385	317			33	15					G 1/2" ^{1) 2)}
QX52/21	436	344	209	120	43	-	92	78	SAE 2 1/2"	SAE 1 1/4"	G 3/4" ^{1) 2)}
QX52/31	451	359			39	15					SAE 1"
QX52/41	489	397	217	127	32	23	92	98	SAE 3"	SAE 1 1/2"	G 3/4" ^{1) 2)}
QX62/31	501	409	247	144	47	14					SAE 1"
QX62/41	524	432			39	27	SAE 1 1/4"				
QX62/51	561	469	252	149	40	28	117	125	SAE 3 1/2"	SAE 2"	SAE 1 1/4"
QX82/41	629	512	309	179	51	25					SAE 1"
QX82/51	655	538			47	30	SAE 1 1/4"				
QX82/61	682	565			45	35			SAE 4"		SAE 1 1/2"

1) threaded port to DIN 3852, Part 2

2) pressure port to SAE J518 code 61 / ISO 6162-1 can be supplied for pressure ranges 2 and 3

E Double pumps QX.2/2

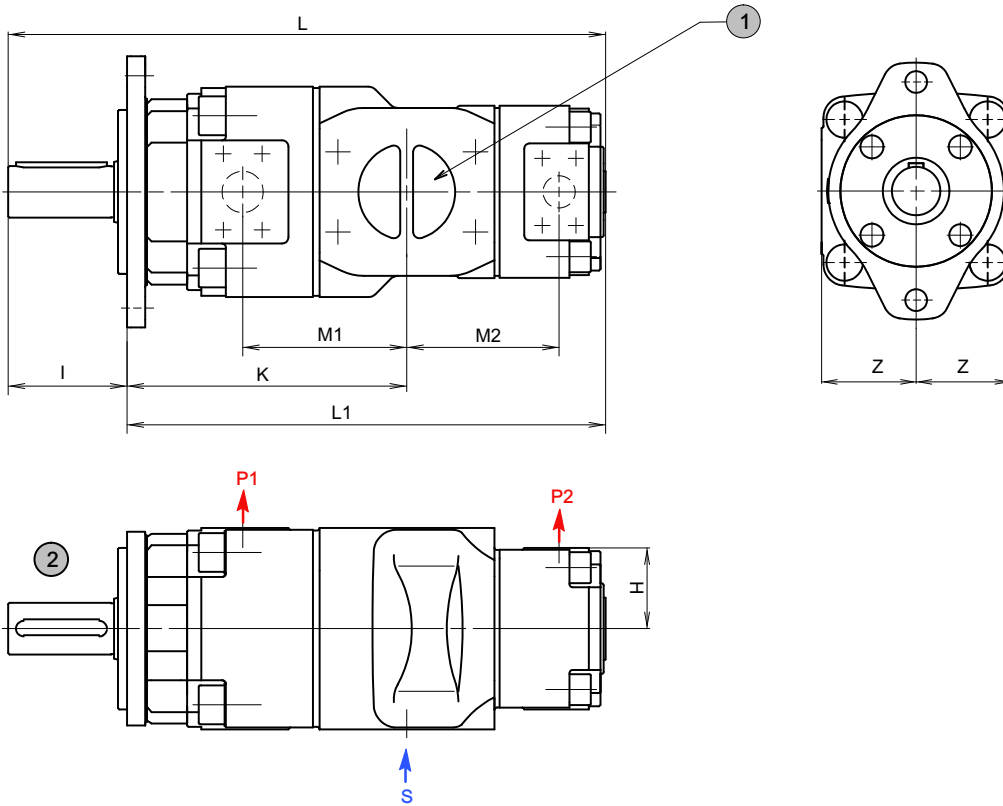

1 S = common suction port

2 Shaft and mounting dimensions - see section 4

Typ	L	L1	K	M1	M2	I	Z	H	S	P1	P2
QX22/22	260	215	123	67	67	45	50	50	G 1 1/4" ¹⁾	G 1/2" ^{1) 2)}	G 1/2" ^{1) 2)}
QX32/22	305	255	151	87	79	50	60		G 1 1/2" ¹⁾	G 3/4" ^{1) 2)}	
QX32/32	318	268			87			87			68
QX42/22	352	284	175	103	84	50	G 1/2" ^{1) 2)}				
QX42/32	365	297			92	60		G 3/4" ^{1) 2)}			
QX42/42	397	329	182	111	111	63	SAE 1"				
QX52/22	418	326	209	120	92	92	78	50	SAE 2 1/2"	SAE 1 1/4"	G 1/2" ^{1) 2)}
QX52/32	431	339			100						60
QX52/42	463	371	217	127	118	92	78	63	SAE 3"	SAE 1"	SAE 1"
QX52/52	483	391			127						78
QX62/32	481	389	247	144	112	92	98	60	SAE 3 1/2"	SAE 1 1/2"	G 3/4" ^{1) 2)}
QX62/42	498	406			123						63
QX62/52	529	437	252	149	137	92	98	78	SAE 3 1/2"	SAE 1 1/2"	SAE 1 1/4"
QX62/62	548	456			149						98
QX82/42	603	486	309	179	141	117	125	63	SAE 3 1/2"	SAE 2"	SAE 1"
QX82/52	623	506			150			78			SAE 1 1/4"
QX82/62	642	525			162			98	SAE 1 1/2"		
QX82/82	674	557			179			125	SAE 4"		SAE 2"

1) threaded port to DIN 3852, Part 2

2) pressure port to SAE J518 code 61 / ISO 6162-1 can be supplied for pressure ranges 2 and 3

F Double pumps QX.2/3

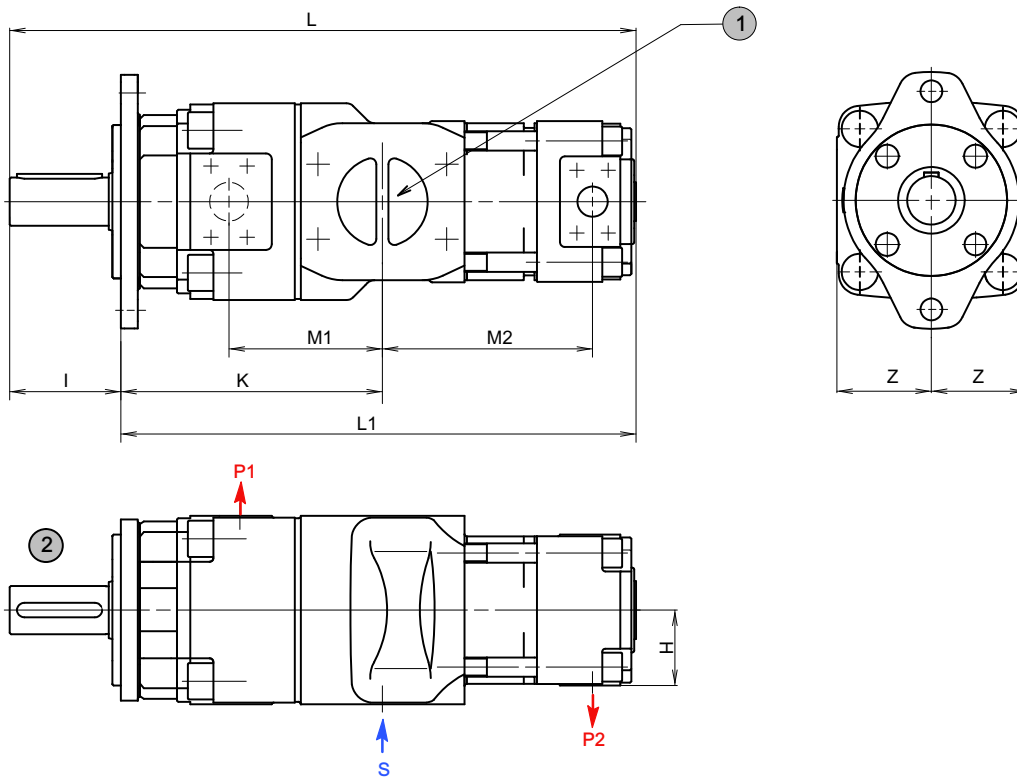

1 S = common suction port

2 Shaft and mounting dimensions - see section 4

Typ	L	L1	K	M1	M2	I	Z	H	S	P1	P2
QX32/23	340	290	151	87	114	50	60	50	G 1 1/2" ¹⁾	G 3/4" ^{1) 2)}	G 1/2" ^{1) 2)}
QX42/23	387	319	175	103	119	68	63		SAE 2"	SAE 1"	
QX42/33	410	342			137			92			78
QX52/23	453	361	209	120	127	92	78		50	SAE 2 1/2"	
QX52/33	476	384			145			174			92
QX52/43	519	427	217	144	179	92	98		63	SAE 3"	
QX62/33	526	434	247					149			207
QX62/43	554	462		309	179	197	92		98	63	
QX62/53	599	507	252					179			220
QX82/43	659	542		252	179	220	117		125	63	
QX82/53	693	576	615					179			252
QX82/63	732	615		615	179	252	117		125	98	

1) threaded port to DIN 3852, Part 2

2) pressure port to SAE J518 code 61 / ISO 6162-1 can be supplied for pressure ranges 2 and 3

G Double pumps QX.3/1

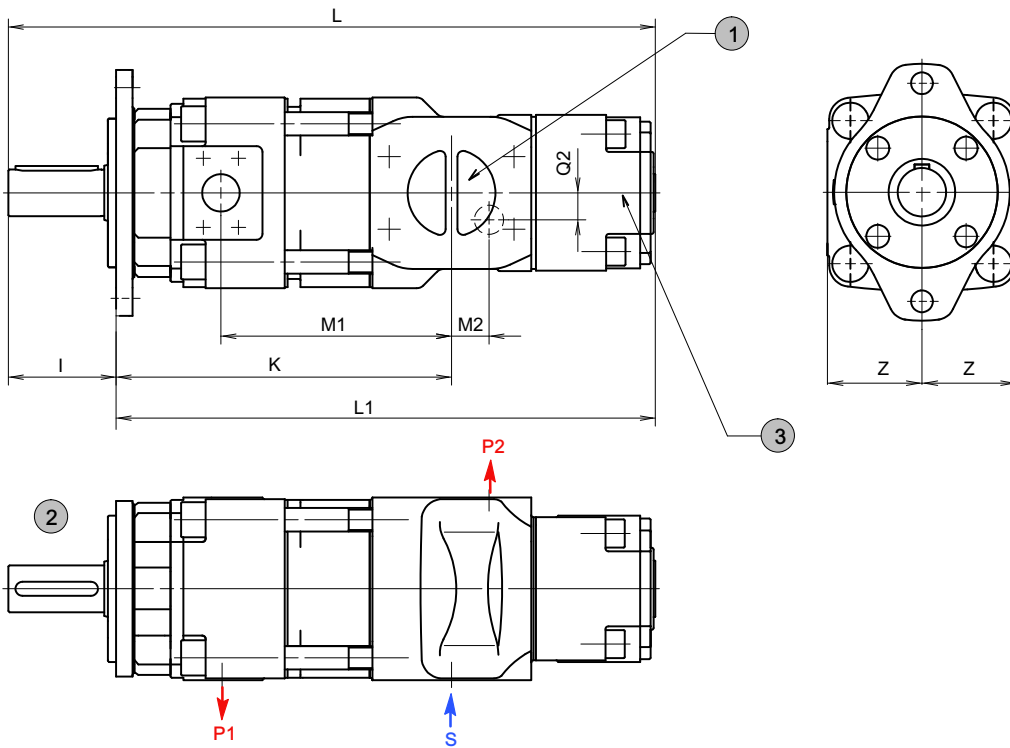

1	S = common suction port
2	Shaft and mounting dimensions - see section 4

3	depending on operating conditions, a second suction port may be required - see section 2.2.1 QX61 SAE 2"
---	--

Typ	L	L1	K	M1	M2	Q2	I	Z	S	P1	P2
QX33/21	368	318	196	132	30	-	50	60	G 1 1/2" ¹⁾	G 3/4" ^{1) 2)}	G 1/2" ^{1) 2)}
QX43/21	426	358	231	159	35	15	68	63	SAE 2"	SAE 1"	
QX43/31	441	373			43						-
QX53/21	506	414	279	190	39	15	92	78	SAE 2 1/2"	SAE 1 1/4"	G 1/2" ^{1) 2)}
QX53/31	521	429			32	23					98
QX53/41	559	467	337	197	47	14	92	98	SAE 3"	SAE 1 1/2"	SAE 1"
QX63/31	591	499			39	27					117
QX63/41	614	522	342	239	40	28	117	125	SAE 3 1/2"	SAE 2"	SAE 1"
QX63/51	651	559			51	25					117
QX83/41	744	627	424	294	47	30	117	125	SAE 3 1/2"	SAE 2"	SAE 1"
QX83/51	770	653			45	35					117
QX83/61	797	680									SAE 1 1/2"

1) threaded port to DIN 3852, Part 2

2) pressure port to SAE J518 code 61 / ISO 6162-1 can be supplied for pressure ranges 2 and 3

H Double pumps QX.3/2

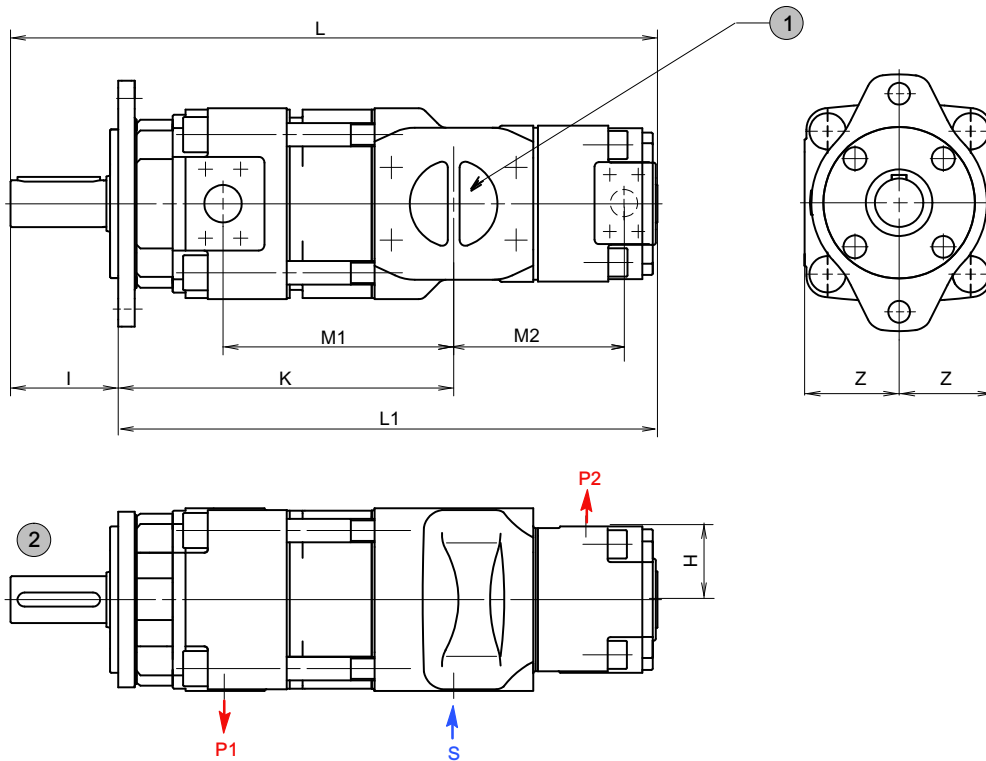

1 S = common suction port

2 Shaft and mounting dimensions - see section 4

Typ	L	L1	K	M1	M2	I	Z	H	S	P1	P2
QX23/22	295	250	158	102	67	45	50	50	G 1 1/4" ¹⁾	G 1/2" ^{1) 2)}	G 1/2" ^{1) 2)}
QX33/22	350	300	196	132	79	50	60	60			
QX33/32	363	313			87				68	63	50
QX43/22	408	340	231	159	92	63	60	SAE 2"			
QX43/32	421	353			111				238	167	63
QX43/42	453	385	279	190	92	92	78	50			
QX53/22	488	396			100				197	118	92
QX53/32	500	408	118	287	127	92	78	63			
QX53/42	533	441	127						337	234	92
QX53/52	553	461	112	342	239	92	98	63			
QX63/32	571	479	123						337	234	92
QX63/42	588	496	137	342	239	92	98	78			
QX63/52	619	527	149						342	239	92
QX63/62	638	546	141	424	294	117	125	63			
QX83/42	718	601	150						424	294	117
QX83/52	738	621	162	424	294	117	125	98			
QX83/62	757	640	179						424	294	117
QX83/82	789	672		424	294	117	125	125			

1) threaded port to DIN 3852, Part 2

2) pressure port to SAE J518 code 61 / ISO 6162-1 can be supplied for pressure ranges 2 and 3

I Double pumps QX.3/3

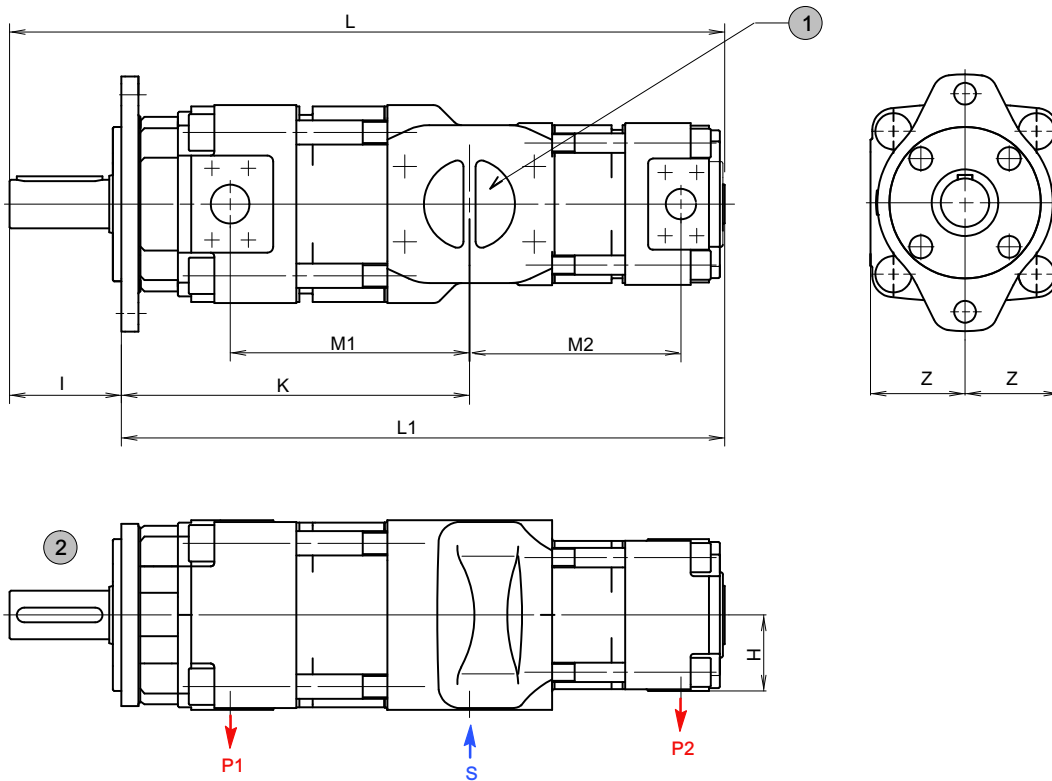

1 S = common suction port

2 Shaft and mounting dimensions - see section 4

Typ	L	L1	K	M1	M2	I	Z	H	S	P1	P2
QX23/23	330	285	158	102	102	45	50	50	G 1 1/4" ^{1) 2)}	G 1/2" ^{1) 2)}	G 1/2" ^{1) 2)}
QX33/23	385	335	196	132	114	50	60	50	G 1 1/2" ^{1) 2)}	G 3/4" ^{1) 2)}	G 1/2" ^{1) 2)}
QX33/33	408	358			132			60			G 3/4" ^{1) 2)}
QX43/23	442	374	231	159	119	68	63	50	SAE 2"	SAE 1"	G 1/2" ^{1) 2)}
QX43/33	466	398			137			60			G 3/4" ¹⁾
QX43/43	509	441			167			63			SAE 1"
QX53/23	523	431	279	190	127	92	78	50	SAE 2 1/2"	SAE 1 1/4"	G 1/2" ^{1) 2)}
QX53/33	546	454			145			60			G 3/4" ^{1) 2)}
QX53/43	589	497	287	197	174	92	98	63	SAE 3"	SAE 1 1/4"	SAE 1"
QX53/53	623	531			197			78			SAE 1 1/4"
QX63/33	616	524			337			234			157
QX63/43	644	552	179	63		SAE 1"					
QX63/53	689	597	342	239	207	92	98	78	SAE 3 1/2"	SAE 1 1/2"	SAE 1 1/4"
QX63/63	728	636			239			98			SAE 1 1/2"
QX83/43	774	657			424			294			197
QX83/53	808	691	220	78		SAE 1 1/4"					
QX83/63	847	730	252	98		SAE 1 1/2"					
QX83/83	904	787	294	125		SAE 2"					

1) threaded port to DIN 3852, Part 2

2) pressure port to SAE J518 code 61 / ISO 6162-1 can be supplied for pressure ranges 2+3

5.3 Ordering code for double pumps

		Q	X	6	3	-	0	8	0	/	3	1	-	0	2	0	R	*	*
Series	= QX																		
Frame size	= 2 / 3 / 4 / 5 / 6 / 8																		
Pressure range	= 1 / 2 / 3																		
Displacement in cm ³ /rev	= 005 - 500																		
Rotation (viewed from shaft end)	right (CW) = R (Standard) left (CCW) = L																		
Option	(see section 4.7 for a selection)																		

Ordering example:

Required:	double pump
Pump 1	
Displacement:	80 cm ³ /rev
Continuous pressure:	300 bar
Type:	63-080
Pump 2	
Displacement:	20 cm ³ /rev
Continuous pressure:	160 bar
Type:	31-020
for use with mineral oil	
Ordering code:	QX63-080/31-020R

6 Triple pumps

The following table shows the triple-pump combinations that can be supplied. Other triple-pump combinations can be assembled after consultation with the factory. The individual pumps 1, 2 and 3 must be specified in accordance with the main characteristics shown in section 2.

The largest pump of the combination is situated at the shaft end and is referred to as Pump 1. For equal frame sizes, the pump with the larger displacement is situated at the drive side. Pumps 2 and 3 have a common suction port.

6.1 Selection table

Frame size of Pump 1

QX2.	QX3.	QX4.	QX5.	QX5.	QX6.	QX8.
QX21/21/21	QX31/21/21	QX41/21/21	QX51/22/23	QX52/52/31	QX61/31/33	QX81/42/23
QX21/21/22	QX31/21/22	QX41/21/23	QX51/23/23	QX52/52/42	QX61/41/21	QX82/42/43
QX21/21/23	QX31/21/23	QX41/22/22	QX52/23/23	QX52/52/43	QX61/41/42	QX82/51/53
QX21/22/22	QX31/22/22	QX41/23/23	QX53/22/22	QX52/52/52	QX61/42/23	QX83/51/53
QX21/22/23	QX31/22/23	QX42/22/22	QX51/31/33	QX52/52/53	QX61/42/43	QX81/61/61
QX21/23/23	QX31/23/22	QX43/22/22	QX51/33/33	QX52/53/31	QX61/43/43	QX81/62/63
QX22/22/22	QX31/23/23	QX43/23/22	QX51/41/23	QX52/53/53	QX62/41/22	QX81/63/33
QX22/22/23	QX32/22/22	QX43/23/23	QX51/41/42	QX53/53/23	QX62/42/42	QX82/61/61
QX23/23/23	QX32/22/23	QX41/31/33	QX51/41/43	QX53/53/33	QX62/43/43	QX82/62/62
	QX32/23/23	QX41/33/22	QX51/42/22		QX63/43/22	QX82/63/31
	QX33/21/22	QX41/33/33	QX51/42/43		QX61/52/53	QX83/61/61
	QX33/21/23	QX42/31/32	QX51/43/21		QX61/53/23	QX83/63/43
	QX33/23/23	QX42/32/32	QX51/43/22		QX61/53/31	QX83/63/61
	QX31/31/21	QX42/33/32	QX51/43/23		QX62/52/32	QX81/81/61
	QX31/31/22	QX43/31/31	QX51/43/43		QX62/52/52	QX81/81/81
	QX31/31/23	QX43/33/33	QX52/42/23		QX62/53/22	QX82/82/52
	QX31/31/31	QX41/41/33	QX52/42/42		QX62/53/23	QX82/82/62
	QX31/31/33	QX41/42/21	QX52/43/22		QX62/53/31	QX82/82/63
	QX31/32/22	QX41/42/23	QX52/43/23		QX62/53/33	QX83/83/53
	QX31/33/33	QX41/42/42	QX52/43/43		QX63/51/51	
	QX32/32/22	QX41/43/21	QX53/41/22		QX63/53/53	
	QX32/32/23	QX41/43/22	QX53/41/23		QX61/61/31	
	QX32/32/32	QX41/43/23	QX53/42/22		QX61/61/33	
	QX32/32/33	QX42/42/22	QX53/42/43		QX61/61/41	
	QX33/33/23	QX42/42/23	QX53/43/23		QX61/61/53	
	QX33/33/33	QX42/42/31	QX51/51/21*		QX61/62/42	
		QX42/42/32	QX51/51/32		QX61/62/63	
		QX42/42/33	QX51/51/33		QX61/63/32	
		QX42/42/42	QX51/52/32		QX61/63/33	
		QX42/42/43	QX51/52/33		QX61/63/41	
		QX43/43/43	QX51/52/42		QX61/63/42	
			QX51/52/43		QX62/62/33	
			QX51/53/22		QX62/62/43	
			QX51/53/23		QX62/62/53	
			QX51/53/31		QX62/62/62	
			QX51/53/33		QX62/62/63	
			QX51/53/41		QX62/63/63	
			QX51/53/43		QX63/63/32	
			QX51/53/52		QX63/63/43	
			QX52/52/23		QX63/63/53	
65	130	260	520	520	1050	2100

Maximum permissible drive shaft torque in Nm

* this pump is used as the ordering example in section 6.2

6.2 Ordering code for triple pumps



Triple pumps can only be supplied after consultation with the factory.

			Q X	5	1	-	1	2	5	/	5	1	-	0	8	0	/	2	1	-	0	1	2	R	*	*
Series	=	QX																								
Frame size	=	2 / 3 / 4 / 5 / 6 / 8																								
Pressure range	=	1 / 2 / 3																								
Displacement in cm ³ /rev	=	005 - 500																								
Frame size	=	2 / 3 / 4 / 5 / 6 / 8																								
Pressure range	=	1 / 2 / 3																								
Displacement in cm ³ /rev	=	005 - 500																								
Frame size	=	2 / 3 / 4 / 5 / 6 / 8																								
Pressure range	=	1 / 2 / 3																								
Displacement in cm ³ /rev	=	005 - 500																								
Rotation (viewed from shaft end)							right (CW)		=		R (Standard)															
							left (CCW)		=		L															
Option	(see section 4.7 for a selection)																									

Ordering example:

Required:	triple pump	Pump 3	
Pump 1		Displacement:	12 cm ³ /rev
Displacement:	125 cm ³ /rev	Continuous pressure:	125 bar
Continuous pressure:	80 bar	Type:	21-012
Type:	51-125		
Pump 2		For use with mineral oil	
Displacement:	80 cm ³ /rev	Referring to the selection table in sect. 6.1, QX51/51/21 is	
Continuous pressure:	150 bar	an obtainable combination.	
Type:	51-080	Ordering code:	QX51-125/51-080/21-012R

7 Low-flow capability pumps

7.1 Generals

The QX24 internal gear pump is a further development of the Bucher internal gear pump. With displacements from

3,3 to 8 cm³/rev, it extends the low-flow capability of the QX range.

7.2 Technical data

Mounting attitude	unrestricted
Mounting method (standard)	oval 2-hole flange to ISO 3019/2 (metric)
Direction of rotation	right, alternatively left (but not reversible)
Pump drive method	in-line, by flexible coupling
Fluids	HLP mineral oils to DIN 51524, Part 2 HFC fluids to VDMA 24317 other fluids - consult Bucher Hydraulics
Minimum fluid cleanliness	NAS 1638, class 9 or ISO 4406, code 20/18/15
Operating viscosity	20 - 100 mm ² /s
Starting viscosity	20 - 300 mm ² /s (higher values, contact Bucher Hydraulics)
Fluid temperature	HLP mineral oils 80 °C max. / -20 °C min. (Considering viscosity field) HFC 50 °C max.
Minimum inlet pressure	0.85 bar absolute
Maximum pressure at drain port	1.5 bar absolute
External drain port	is always provided

7.3 Main characteristics

Effective displacement effectif	Flow rate ¹⁾	Maximum speed	Type	Mineral oil to	HFC to	Torque ³⁾	Power requirement ⁴⁾
				DIN 51524	VDMA 24317		
cm ³ /rev	l/min	rpm		Cont./Max. interm. pressure ²⁾	bar	Nm	KW
3,3	4,8	3600	QX24-003	320/400	280/350	17	2,6
4,2	6,2	3600	QX24-004	320/400	280/350	21,5	3,2
5,1	7,4	3600	QX24-005	360/400	320/350	30	4,5
6,3	9,1	3600	QX24-006	360/400	320/350	36	5,5
8,0	11,5	3600	QX24-008	360/400	320/350	46	7,0



The main characteristics are valid for hydraulic oils as well as fire-resistant and environmentally-friendly fluids with a viscosity of 20 to 50 mm²/s

1) at speed n = 1450 rpm (theoretical)

2) maximum intermittent pressure for max. 20 sec. but not more than 10% of the duty cycle

3) theoretical value at the max. permitted continuous pressure for mineral oil

4) theoretical value at the max. permitted continuous pressure for mineral oil at n = 1450 rpm

7.4 Volumetric efficiency (η)

measured at speed 1450 rpm; viscosity 42 mm²/s

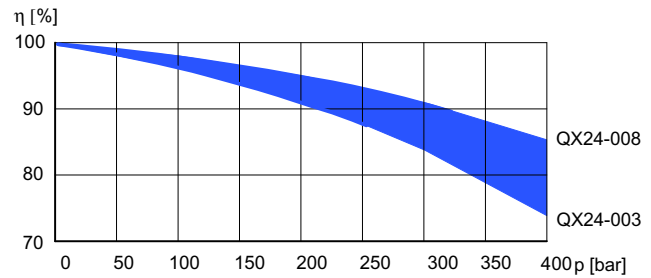

7.5 Single pumps

7.5.1 Dimensions

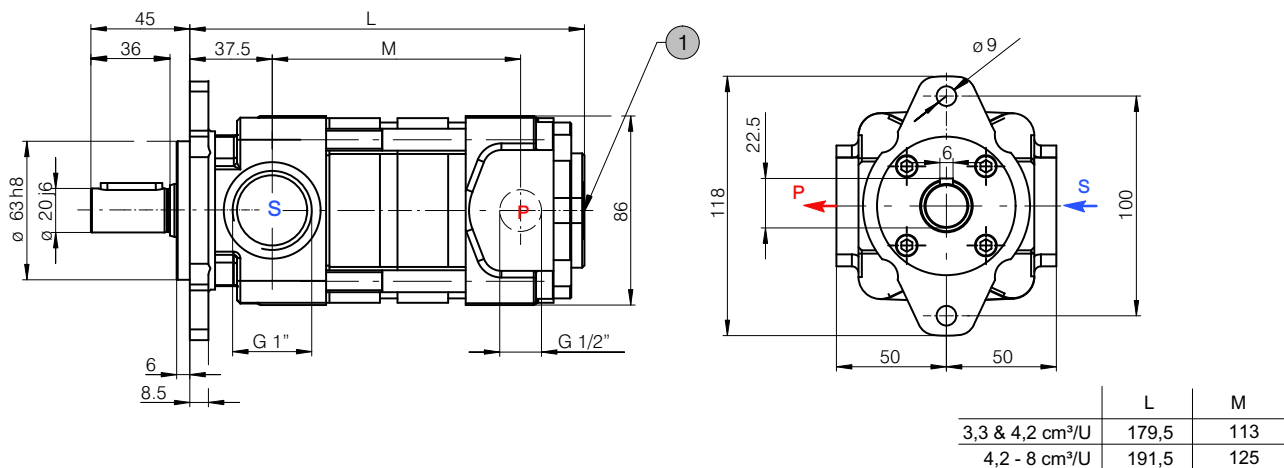

1 external drain port G1/4"

7.5.2 Ordering codes

		Q	X	2	4	-	0	0	4	R	-	06	-	*	*
Series	= QX														
Size	= 2														
Pressure range	= 4														
Displacement in cm ³ /rev	= 003, 004, 005, 006 and 008														
Direction of rotation (viewed from shaft end)	right (CW) = R left (CCW) = L														
External drain port	= 06														
Option	contact Bucher Hydraulics														

7.5.3 Standard configuration

- direction of rotation "right"
- 2- hole mounting flange to ISO 3019/2 (metric)
- Nitrile seals
- cylindrical shaft end to ISO R775
- separate drain port G 1/4 in rear cover of the pump

7.6 QX24 pumps combined with other QX-singel pumps

7.6.1 Dimensions

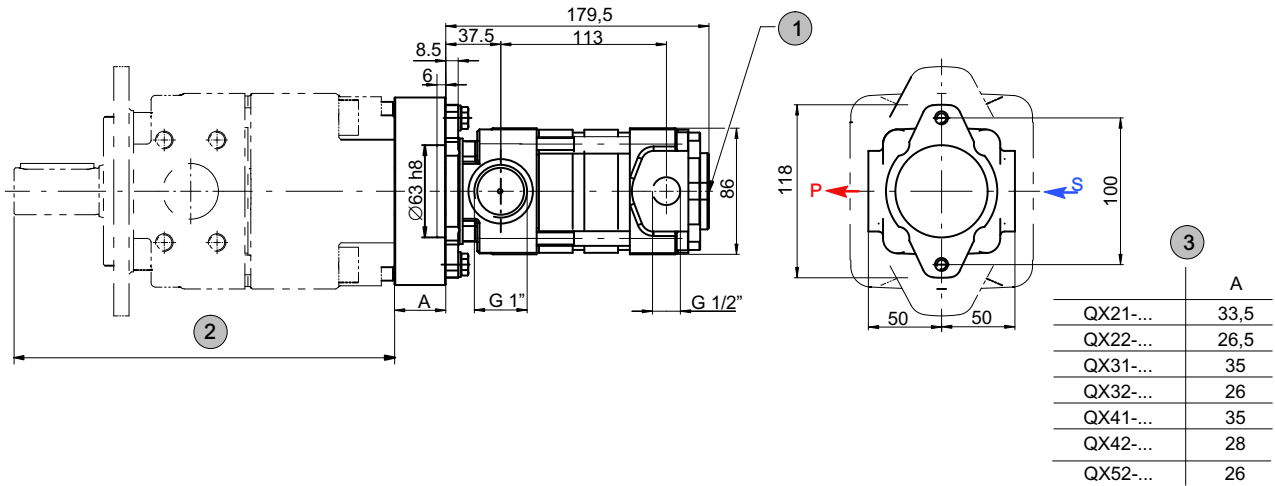

1	external drain port G 1/4"
2	dimensions see section 4

3	dimension A depends on the driving QX pump model (2)
---	--

7.6.2 Ordering code

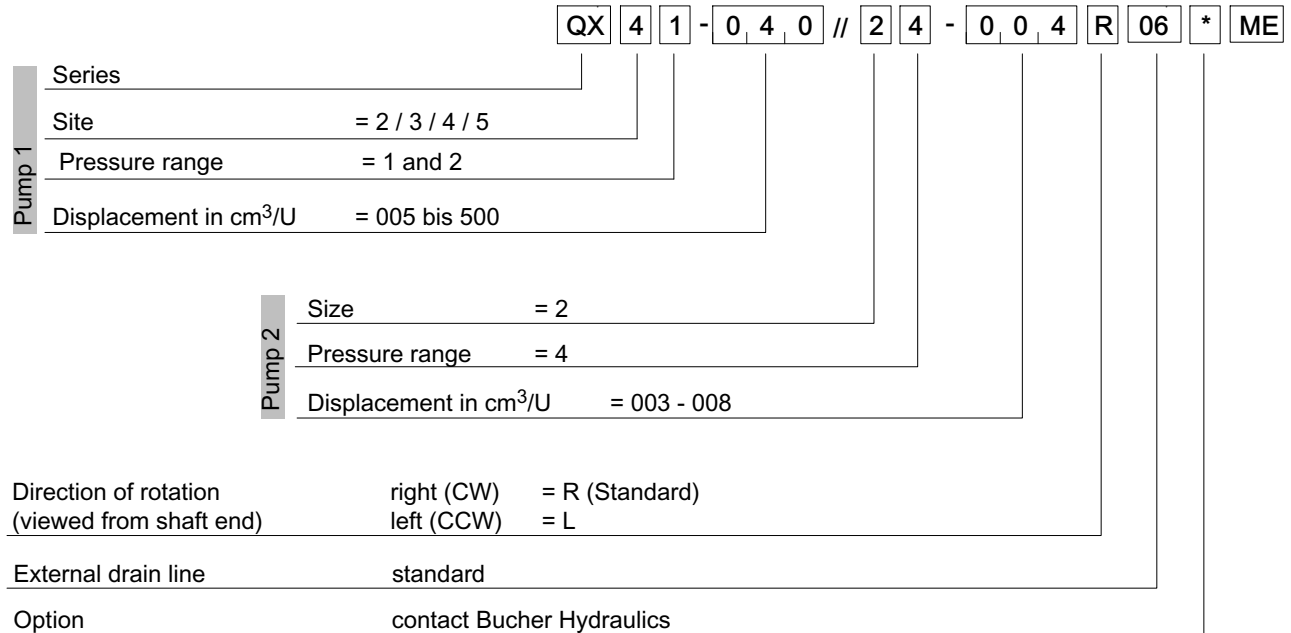

Ordering example:

Require: Double pump

Pump 1

Displacement: 40 cm³/rev

Continuous pressure: 160 bar

Type: 41 - 040

Pump 2

Displacement: 4 cm³/rev

Continuous pressure: 250 bar

Type: 24 - 004

For use with mineral oil:

Ordering code: QX41-040//24-004R 06-ME

8 Fluid cleanliness

QX pumps require fluid with a minimum cleanliness level of NAS 1638, Class 9 or ISO 4406, code 20/18/15.

HLP hydraulic oils to DIN 51524, Part 2, can be used without any special restriction as long as they remain within the specified temperature and viscosity ranges. HFC fire-resistant fluids to DIN 51502 can be used. Note that all fire-resistant fluids require special versions of the pumps or motors and must be approved by Bucher Hydraulics. We recommend the use of fluids that contain anti-wear additives for mixed-friction operating conditions. Fluids without appropriate additives can reduce the service life of pumps and motors. The user is responsible for maintaining, and regularly checking, the fluid quality. Bucher Hydraulics recommends a load capacity of $\geq 30 \text{ N/mm}^2$ to Brugger DIN 51347-2.

9 Fluid cleanliness

Cleanliness class (RK) onto ISO 4406 and NAS 1638

Code ISO 4406	Number of particles / 100 ml			
	$\leq 4 \mu\text{m}$	$\leq 6 \mu\text{m}$	$\leq 14 \mu\text{m}$	NAS 1638
23/21/18	8000000	2000000	250000	12
22/20/18	4000000	1000000	250000	-
22/20/17	4000000	1000000	130000	11
22/20/16	4000000	1000000	64000	-
21/19/16	2000000	500000	64000	10
20/18/15	1000000	250000	32000	9
19/17/14	500000	1300000	16000	8
18/16/13	250000	64000	8000	7
17/15/12	130000	32000	4000	6
16/14/12	64000	16000	4000	-
16/14/11	64000	16000	2000	5
15/13/10	32000	8000	1000	4
14/12/9	16000	4000	500	3
13/11/8	8000	2000	250	2

10 Operational reliability

To guarantee the reliable operation and a long service life of the pump, a maintenance schedule must be prepared for the power unit, machine or system. The maintenance schedule must make sure that the provided or permissible operating conditions of the pump are adhered to over the period of use.

In particular, compliance with the following operating parameters must be ensured:

- The required oil cleanliness
- The operating temperature range
- The fluid level

Moreover, the pump and the system must be inspected at regular intervals for changes in the following parameters:

- Vibration
- Noise
- Differential temperature of pump – fluid in the tank
- Foaming in the tank
- Freedom from leakage

Changes in these parameters indicate wear of components (e.g. drive motor, coupling, pump, etc.). The cause must be immediately pinpointed and eliminated.





To provide high operational reliability of the pump in the machine or system, we recommend continuous, automatic checks of the above parameters and an automatic shutdown in the case of changes that exceed the usual fluctuations within the provided operating range.

11 Note

This catalogue is intended for users with specialist knowledge. The user must check the suitability of the equipment described herein in order to ensure that all of the conditions necessary for the safety and proper functioning of the system are fulfilled. If you have any doubts or questions concerning the use of these pumps, please consult Bucher Hydraulics.

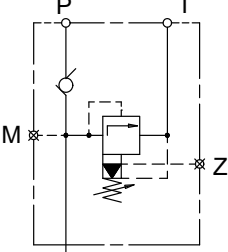
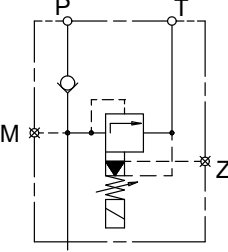
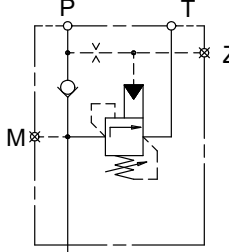
12 Accessories

12.1 Bolt-on valves - SAE J518 code 61 / ISO 6162-1 pattern

Pressure relief valve A _G DF / ASDH	Pressure relief valve solenoid control A _G DA	Accumulator charging valve AGSF
		
		
<p>Technical data sheet 100-P-000123</p>	<p>Technical data sheet 100-P-000119</p>	<p>Technical data sheet 100-P-0000124</p>

12.1.1 Examples for Bolt-on valves, mounted on QX Internal Gear Pumps

Bolt-on valve with threaded ports AGDF	Bolt-on valves with pipe flanges SAE ¹⁾ ASDF+RF	Bolt-on valve with pipe flanges SAE + RVSAE ²⁾ ASDF+RF+RVSAE+DPSAE+ZPSAE
		

1) Pipe flange see chapter 12.2

2) Please ask BUCHER HYDRAULICS for check valves



IMPORTANT: For detailed informations on Bolt-on valves see www.bucherhydraulics.com

12.2 Pipe flanges - high pressure type

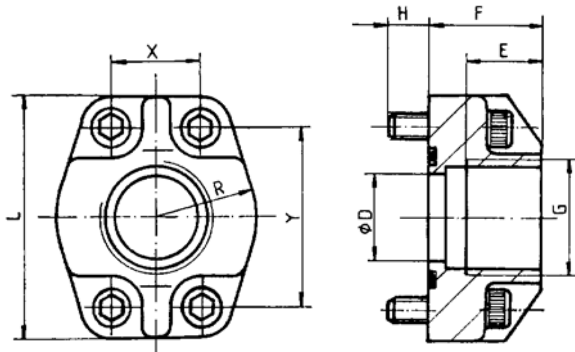

- Max. operating pressure 420 bar
- Flange size SAE J518 code 61 / ISO 6162-1

Threaded pipe flanges are spot-faced for DIN 2353 pipe fittings
Material: ST37 / For Viton seals, contact Bucher Hydraulics

Ordering number	Ordering code	Size	DØ	E	F	H	L	R	X	Y	Viton seal 90 Shore 'A'	Retaining screws DIN912-12.9 / Nm	
037000	RF 01-R08	G 1/2"	12,5	16	27	13	54	23	17,5	38	20,24x2,62	M8x30	30
037010	RF 02-R10	G 3/4"	20	18	30	12	65	26	22,2	47,6	26,65x2,62	M10x30	60
037020	RF 03-R11	G 1"	25	20	34	13	70	29	26,2	52,4	32,99x2,62	M10x35	60
037030	RF 04-R12	G 1 1/4"	32	22	38	14	80	36	30,2	58,6	40,86x3,53	M10x40	60
037040	RF 05-R13	G 1 1/2"	38	24	41	19	94	41	35,7	70	44,04x3,53	M12x45	120
037050	RF 06-R14	G 2"	50	26	45	20	102	48	42,9	77,8	59,92x3,53	M12x50	120
055470*	RF 07-R16	G 2 1/2" *	63	30	50	18	114	57	50,8	89	72,62x3,53	M12x45	120

* at RF07 only to 210 bar be allowed

12.3 Low pressure type

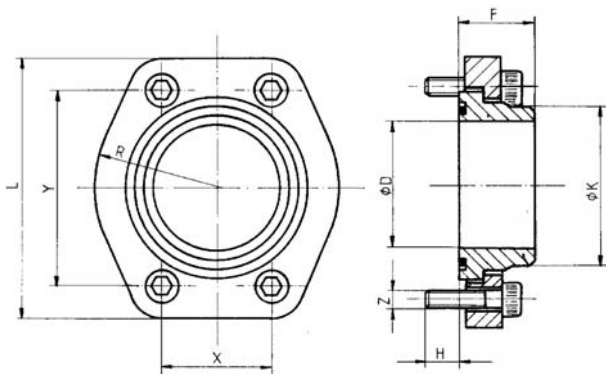

- Max. operating pressure 16 bar
- Flange size SAE J518 code 61 / ISO 6162-1

Material: HST37 / For Viton seals, contact Bucher Hydraulics

Ordering number	Ordering code	SAE flange Size	D	K	F	H	L	R	X	Y	Viton seal 90 Shore 'A'	Retaining screws DIN 912-8.8 Torque Nm		pipe ¹⁾ O/dia. approx.
062450	RN 07-S	2 1/2"	63	75	35	14	120	57	51	89	69,44x3,53	M12 x 30	70	75
063880	RN 08-S	3"	76	88			140,5	68	62	106,5	85,32x3,53	M16 x 40	180	88
063890	RN 09-S	3 1/2"	89	100	40	19	158,5	73	70	120,3	98,02x3,53	M16 x 40	180	100
063900	RN 10-S	4"	103	115			168	79	78	130	110,72x3,53	M16 x 40	180	115

1) We recommend the use of seamless precision steel tube to DIN 2391 with-wallthick. max 6 mm

info.kl@bucherhydraulics.com

www.bucherhydraulics.com

© 2012 by Bucher Hydraulics GmbH, D-79771 Klettgau

All rights reserved.

Data is provided for the purpose of product description only, and must not be construed as warranted characteristics in the legal sense. The information does not relieve users from the duty of conducting their own evaluations and tests. Because the products are subject to continual improvement, we reserve the right to amend the product specifications contained in this catalogue.

Classification: 410.100. 000