

VT6DDS - 038 - 028 - 1 R 00 - A 1 - 00 *

Series - SAE C 6 bolts
Mounting flange J744c

Cam ring for "P1" & "P2"

Volumetric displacement cm³/rev (in³/rev)

*014/B14 = 47.6 (2.90)	035/B35 = 111.0 (6.77)
017/B17 = 58.2 (3.55)	038/B38 = 120.3 (7.34)
020/B20 = 66.0 (4.03)	042/B42 = 136.0 (8.30)
024/B24 = 79.5 (4.85)	045/B45 = 145.7 (8.89)
028/B28 = 89.7 (5.47)	050/B50 = 158.0 (9.64)
031/B31 = 98.3 (6.00)	061/B61 = 190.5 (11.62)

*'0' - Uni - directional 'B' - Bi - directional

Type of Shaft

- 1 - Keyed (SAE C)
- 2 - Keyed (SAE CC)
- 3 - Splined (SAE C)
- 4 - Splined (SAE BB)
- 5 - Keyed (non SAE)



Modifications

Mounting W/connection variables
SAE 4 bolt flange (J518c)

VT6DDS	P1 & P2 = 11"	S=4"
	UNC	METRIC
	00	M0

Seal class

- 1 - S1 (for mineral oil)
- 4 - S4 (for fire resistant fluids)
- 5 - S5 (for mineral oil and fire resistant fluids)

Design letter

Porting combination (see page BM-1-5)
(00 = Standard)

Direction of rotation
(view on shaft end)

- R - Clockwise
- L - Counter - clockwise

INTERNAL LEAKAGE (TYPICAL)

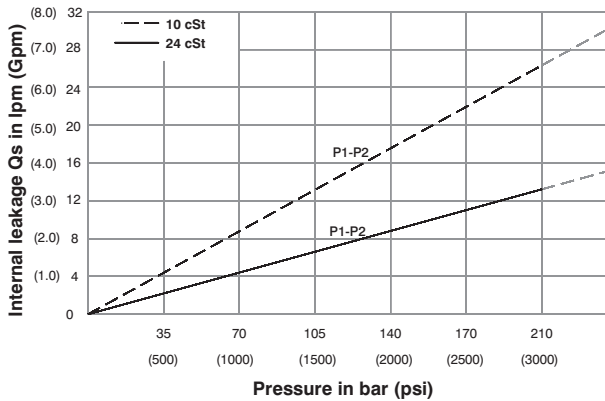

Do not operate pump more than 5 seconds at any speed or viscosity if internal leakage is more than 50% of theoretical flow. Total leakage is the sum of each section loss at its operating conditions.

NOISE LEVEL (TYPICAL)

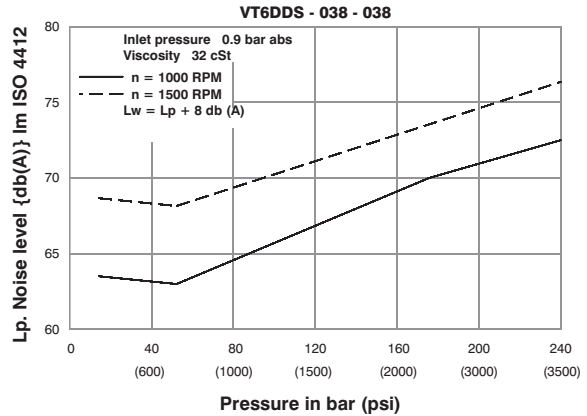

Double pump noise level is given with each section discharging at the pressure noted on the curve.

HYDROMECHANICAL POER LOSS (TYPICAL)

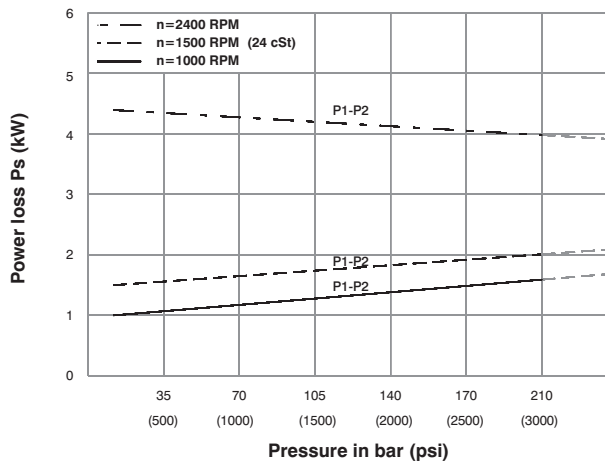

Total hydromechanical power loss is the sum of each section at its operating conditions.

PERMISSIBLE RADIAL LOAD

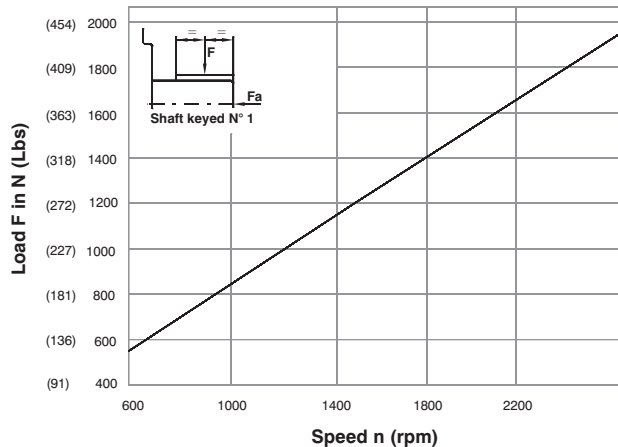

Maximum permissible axial load Fa = 1200 N (270 Lbs)

HIGH PERFORMANCE VANE PUMP VT6DDS

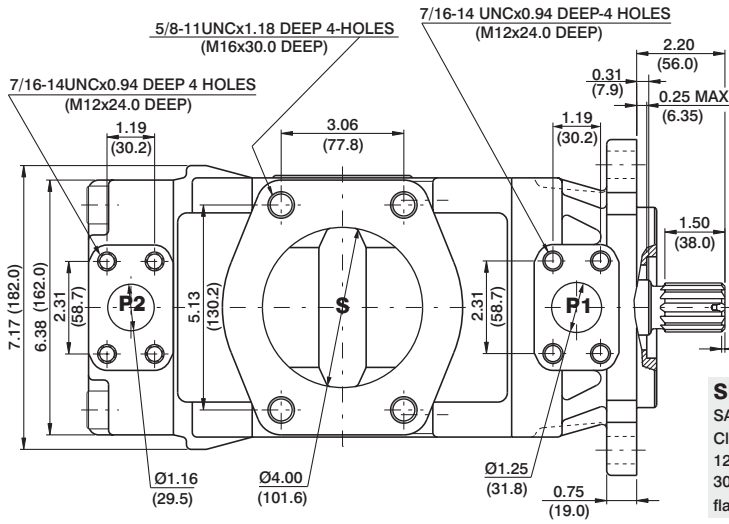

Shaft code 3
SAE C splined shaft
Class 1-J498b
12/24 dp. 14 teeth
30° pressure angle
flat root side fit

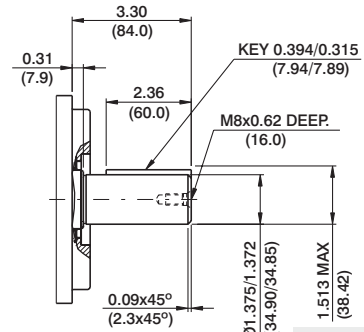

Shaft code 5
(No SAE)

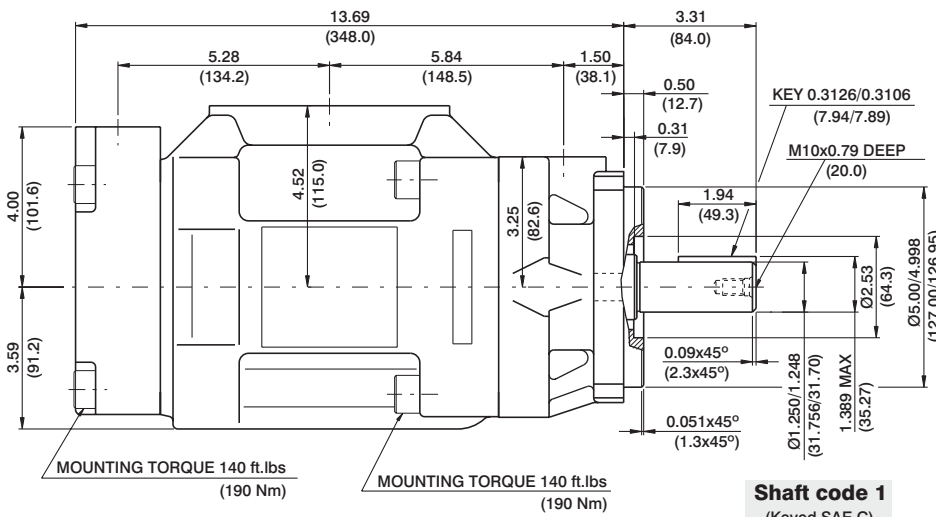

Shaft code 1
(Keyed SAE C)

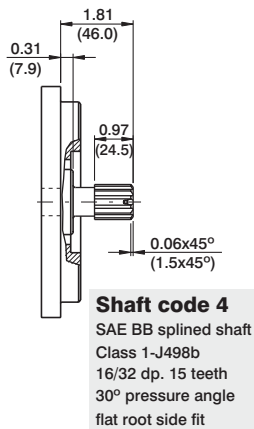
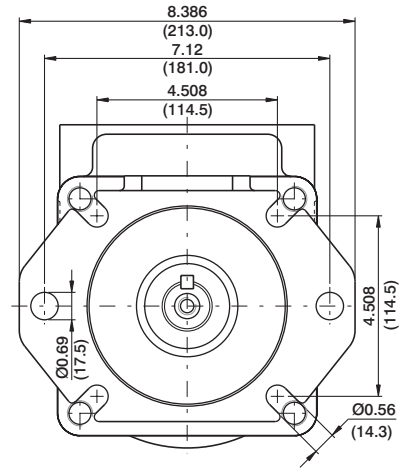

Shaft code 4
SAE BB splined shaft
Class 1-J498b
16/32 dp. 15 teeth
30° pressure angle
flat root side fit

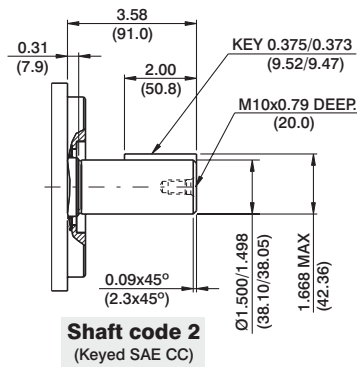

Shaft code 2
(Keyed SAE CC)

Shaft torque limits in ³ /rev x psi (ml/rev x bar)	
Shaft	Vp x p max. (P1+P2)
1	38299 (43240)
3	54152 (61200)
4	31780 (35880)
5	40035 (55600)

OPERATING CHARACTERISTICS - TYPICAL (24 cST) (Input power p (KW) for one cartridge only)

Pressure port	Series	Volumetric Displacement Vp		Flow q & n = 1500 rpm						Input power p & n = 1500 rpm					
		in ³ /rev	cm ³ /rev	p = 0 bar (0 psi)		p = 140 bar (2000 psi)		p = 240 bar (3500 psi)		p = 7 bar (100 psi)		p = 140 bar (2000 psi)		p = 240 bar (3500 psi)	
				gpm	lpm	gpm	lpm	gpm	lpm	hp	kw	hp	kw	hp	kw
P1 & P2	014	2.90	47.6	18.88	71.4	16.42	62.1	14.78	55.9	3.08	2.3	24.81	18.5	41.03	30.6
	017	3.55	58.2	23.1	87.3	20.6	78.0	18.99	71.8	3.35	2.5	29.77	22.2	49.62	37.0
	020	4.00	66.0	26.19	99.0	23.73	89.7	22.08	83.5	3.75	2.8	33.39	24.9	55.92	41.7
	024	4.80	79.5	31.56	119.3	29.10	110.0	27.46	103.8	4.02	3.0	39.69	29.6	66.78	49.8
	028	5.50	89.7	35.58	134.5	33.12	125.2	31.48	119.0	4.29	3.2	44.52	33.2	74.96	55.9
	031	6.00	98.3	39.00	147.5	36.53	138.1	34.89	131.9	4.42	3.3	48.54	36.2	81.80	61.0
	035	6.80	111.0	44.04	166.5	41.58	157.2	39.94	151.0	4.69	3.5	54.58	40.7	92.13	68.7
	038	7.30	120.3	47.72	180.4	45.26	171.1	43.62	164.9	4.96	3.7	58.87	43.9	99.64	74.3
	042 ¹⁾	8.30	136.0	53.96	204.0	51.50	194.7	49.86	188.5	5.36	4.0	66.25	49.4	112.24	83.7
	045 ¹⁾	8.89	145.7	57.80	218.5	55.34	209.2	53.70	203.0	5.50	4.1	70.81	52.8	120.02	89.5
	050 ¹⁾	9.64	158.0	62.69	237.0	60.23	227.7	59.25 ²⁾	224.0 ²⁾	5.90	4.4	76.44	57.0	113.98 ²⁾	85.0 ²⁾
	061 ¹⁾	11.62	190.5	76.25	285.7	73.54 ³⁾	278.0 ³⁾	--	--	6.16	4.6	81.26 ³⁾	60.6 ³⁾	--	--

1) 042-045-050-061=2200 RPM max.

2) 050=210 bar (3000 psi) max.

3) 061 = 120 bar (1740 psi) max. int, 061 = 80 bar (1160 psi) cont.