

# HIGH PERFORMANCE VANE PUMP VT7DBB



**VT7DBB - B38 - B14 - B08 - 1 R 00 - A 1 - M1- \***

**Series**-SAE C 2 bolts  
Mounting flange J744c

**Cam ring for "P1"**

Volumetric displacement cm<sup>3</sup>/rev (in<sup>3</sup>/rev)

B14 = 43.9 (2.68)	B31 = 99.1 (6.05)
B17 = 55.0 (3.36)	B35 = 113.4 (6.92)
B20 = 66.0 (4.03)	B38 = 120.6 (7.36)
B22 = 70.3 (4.29)	B42 = 137.5 (8.39)
B24 = 81.1 (4.95)	045 = 145.7 (8.89)
B28 = 89.9 (5.49)	050 = 157.9 (9.64)

**Cam ring for "P2" & P3**

Volumetric displacement cm<sup>3</sup>/rev (in<sup>3</sup>/rev)

B02 = 5.7 (0.35)	B09 = 28.0 (1.71)
B03 = 9.8 (0.60)	B10 = 31.8 (1.94)
B04 = 12.8 (0.78)	B11 = 34.9 (2.13)
B05 = 15.9 (0.97)	B12 = 40.9 (2.50)
B06 = 19.8 (1.21)	B14 = 45.1 (2.75)
B07 = 22.5 (1.37)	B15 = 50.0 (3.05)
B08 = 24.9 (1.52)	

**Modifications**

**Mounting w/connection variables**

P1=1 1/4" P2=1" P3=3/4" S=4"	
UNC	METRIC
01	M1

**Seal class**

- 1 = S1 (for mineral oil)
- 4 = S4 (for fire resistant fluids)
- 5 = S5 (for mineral oil and fire resistant fluids)

**Design letter**

**Porting combination** (see page CI-1-4,5)

00 = Standard

**Direction of rotation (view on shaft end)**

- R - Clockwise
- L - Counter - clockwise

**Type of Shaft**

- 1 - Keyed (no SAE)
- 2 - Keyed (SAE CC)
- 3 - Splined (SAE C)
- 4 - Splined (SAE CC)



## OPERATING CHARACTERISTICS - TYPICAL (24 cST) (Input power p (KW) for one cartridge only)

Pressure port	Series	Volumetric Displacement Vp		Flow q & n = 1800 rpm						Input power p & n = 1800 rpm					
				p = 0 bar (0 psi)		p = 140 bar (2000 psi)		p = 250 bar (3630 psi)		p = 7 bar (100 psi)		p = 140 bar (2000 psi)		p = 250 bar (3630 psi)	
				in <sup>3</sup> /rev	cm <sup>3</sup> /rev	gpm	lpm	gpm	lpm	gpm	lpm	hp	kw	hp	kw
P1	B14	2.68	43.9	20.92	79.1	19.18	72.5	17.81	67.3	3.46	2.6	27.77	20.7	47.03	35.0
	B17	3.36	55.0	26.16	98.8	24.41	92.3	23.04	87.0	3.77	2.8	33.88	25.3	57.71	43.0
	B20	4.03	66.0	31.39	118.6	29.64	112.0	28.27	106.8	4.07	3.0	39.98	29.8	68.39	50.9
	B22	4.29	70.3	33.43	126.4	31.69	119.8	30.32	104.6	4.19	3.1	42.37	31.6	72.57	54.0
	B24	4.95	81.1	38.57	145.8	36.82	139.2	35.45	134.0	4.49	3.4	48.36	36.1	83.06	61.9
	B28	5.49	89.9	42.80	161.8	41.06	155.2	39.69	150.0	4.74	3.5	53.30	39.7	91.70	68.3
	B31	6.05	99.1	47.18	178.3	45.43	171.7	44.06	166.5	4.99	3.7	58.41	43.6	100.63	75.0
	B35	6.92	113.4	53.93	203.9	52.18	197.2	50.81	192.0	5.39	4.0	66.29	49.4	114.42	85.3
	B38	7.36	120.6	57.35	216.8	55.61	210.2	54.24	204.9	5.59	4.2	70.28	52.4	121.42	90.5
	B42	8.39	137.5	65.39	247.2	63.65	240.6	62.28	235.4	6.05	4.5	79.66	59.4	137.83	102.7
	045	8.89	145.7	69.29	262.0	67.11	253.6	65.31	246.8	6.74	5.0	83.75	62.4	145.79	108.7
	050	9.64	157.9	75.14	284.0	72.96	275.8	71.78 <sup>1)</sup>	271.3 <sup>1)</sup>	7.08	5.3	90.58	67.5	134.50 <sup>1)</sup>	100.3 <sup>1)</sup>
P2 & P3				p = 0 bar (0 psi)		p = 140 bar (2000 psi)		p = 300 bar (4350 psi)		p = 7 bar (100 psi)		p = 140 bar (2000 psi)		p = 300 bar (4350 psi)	
	B02	0.35	5.7	2.76	10.4	2.33	8.8	1.80	6.8	0.74	0.55	4.02	2.99	8.10	6.04
	B03	0.60	9.8	4.66	17.6	4.23	15.9	3.63	14.0	0.85	0.63	6.24	4.65	12.93	9.64
	B04	0.78	12.8	6.09	23.0	5.66	21.4	5.13	19.4	0.94	0.70	7.90	5.89	16.55	12.34
	B05	0.97	15.9	7.56	28.6	7.13	26.9	6.60	25.0	1.02	0.76	9.62	7.17	20.29	15.13
	B06	1.21	19.8	9.42	35.6	8.99	33.9	8.46	32.0	1.13	0.84	11.79	8.79	25.00	18.64
	B07	1.37	22.5	10.70	40.4	10.27	38.8	9.74	36.8	1.20	0.89	13.29	9.91	28.26	21.07
	B08	1.52	24.9	11.84	44.7	11.41	43.1	10.88	41.1	1.27	0.95	14.62	10.90	31.15	23.23
	B09	1.71	28.0	13.31	50.3	12.87	48.6	12.35	47.0	1.36	1.01	16.35	12.19	34.92	26.04
	B10	1.94	31.8	15.12	57.2	14.69	55.5	14.16	53.5	1.46	1.09	18.45	13.75	39.48	29.44
	B11	2.13	34.9	16.64	62.9	16.19	61.2	15.68	59.3	1.55	1.16	20.17	15.04	43.22	32.23
	B12	2.50	40.9	19.50	73.7	19.07	72.1	18.54	70.1	1.72	1.28	23.55	17.56	50.58	37.71
	B14	2.75	45.1	21.40	80.8	20.95	79.2	20.44	77.0	1.83	1.36	25.80	19.24	55.48	41.37
B15	3.05	50.0	23.78	89.8	23.35	88.3	22.88 <sup>2)</sup>	86.5 <sup>2)</sup>	1.97	1.47	28.55	21.28	57.35 <sup>2)</sup>	42.76 <sup>2)</sup>	

1) 050 = 210 bar (3000 psi) max. int

2) B15 = 280 bar (4060 psi) max. int

## INTERNAL LEAKAGE ( TYPICAL )

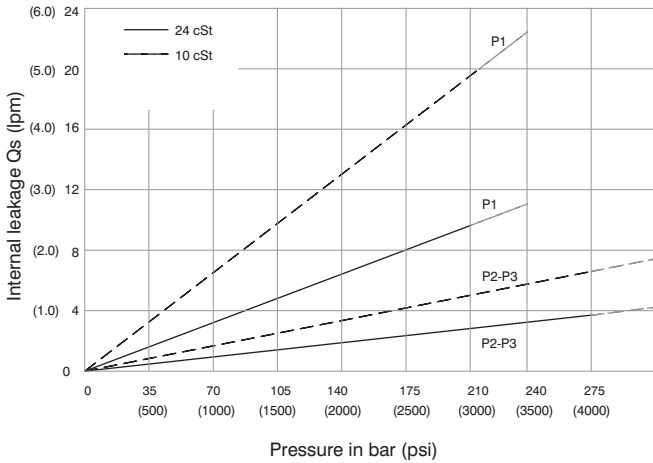

Do not operate pump more than 5 seconds at any speed or viscosity if internal leakage is more than 50% of theoretical flow. Total leakage is the sum of each section loss at its operating conditions.

## NOISE LEVEL ( TYPICAL )

VT7DBB - B38-B06-B04

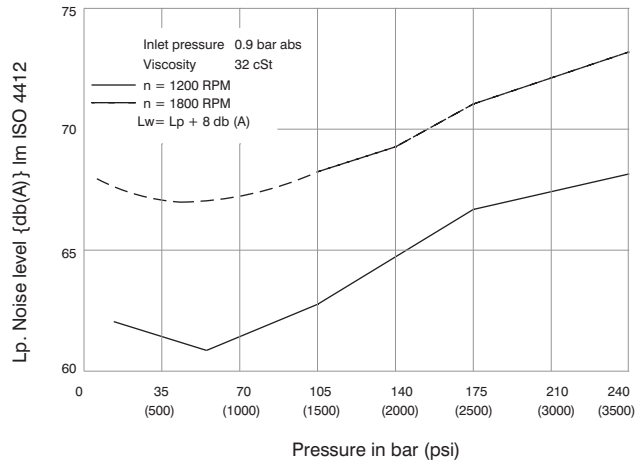

Triple pump noise level is given with each section discharging at the pressure noted on the curve.



## HYDROMECHANICAL POWER LOSS ( TYPICAL )

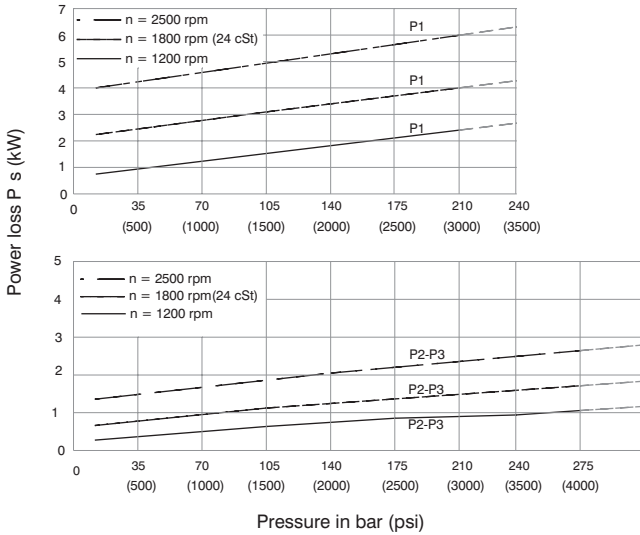

Total hydromechanical power loss is the sum of each section at its operating conditions.

## PERMISSIBLE RADIAL LOAD

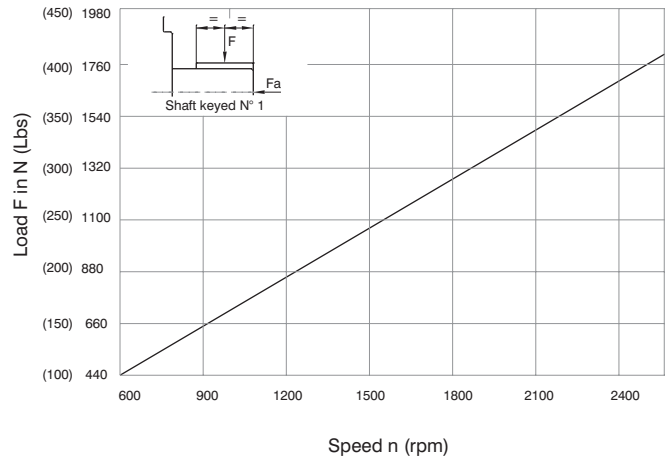

Maximum permissible axial load  $F_a = 1200 \text{ N (270 Lbs)}$

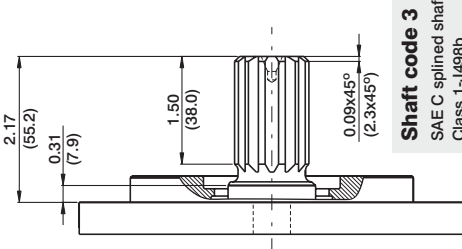
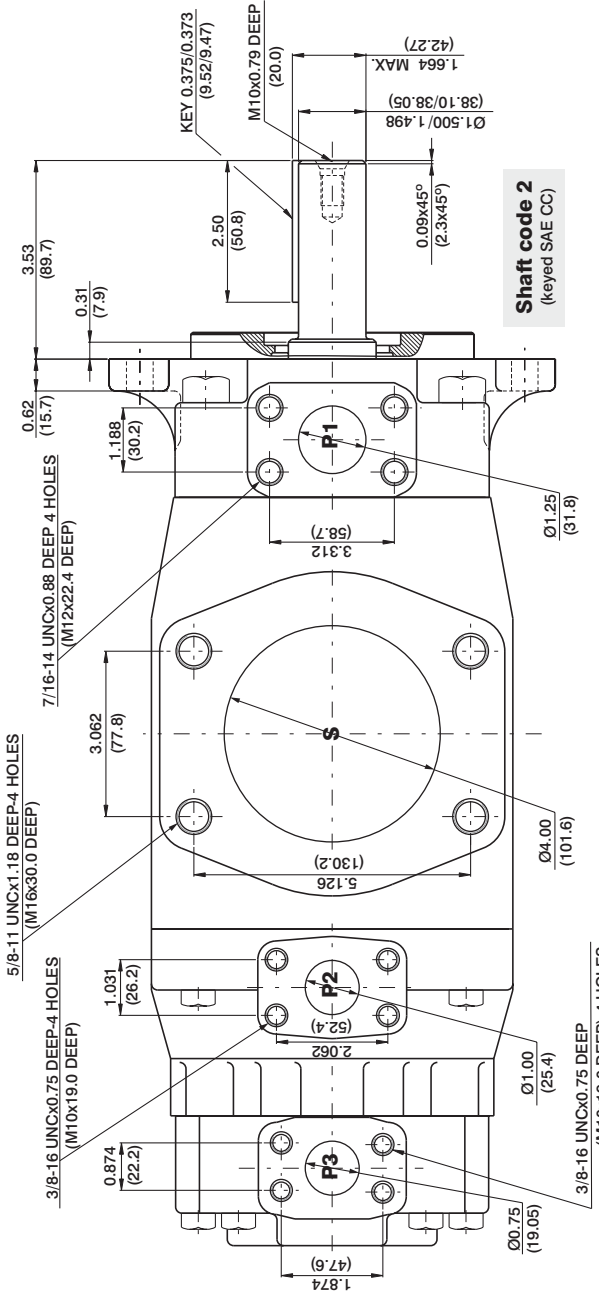

**Shaft code 3**  
SAE C splined shaft  
Class 1-J498b  
12/24 Dp. 14 Teeth  
30° Pressure angle  
Flat root side fit

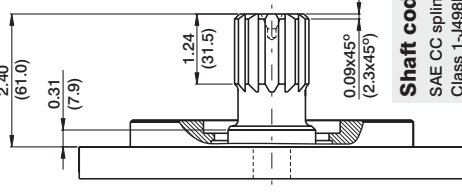

**Shaft code 4**  
SAE CC splined shaft  
Class 1-J498b  
12/24 Dp. 17 Teeth  
30° Pressure angle  
Flat root side fit

**Shaft code 2**  
(keyed SAE CC)

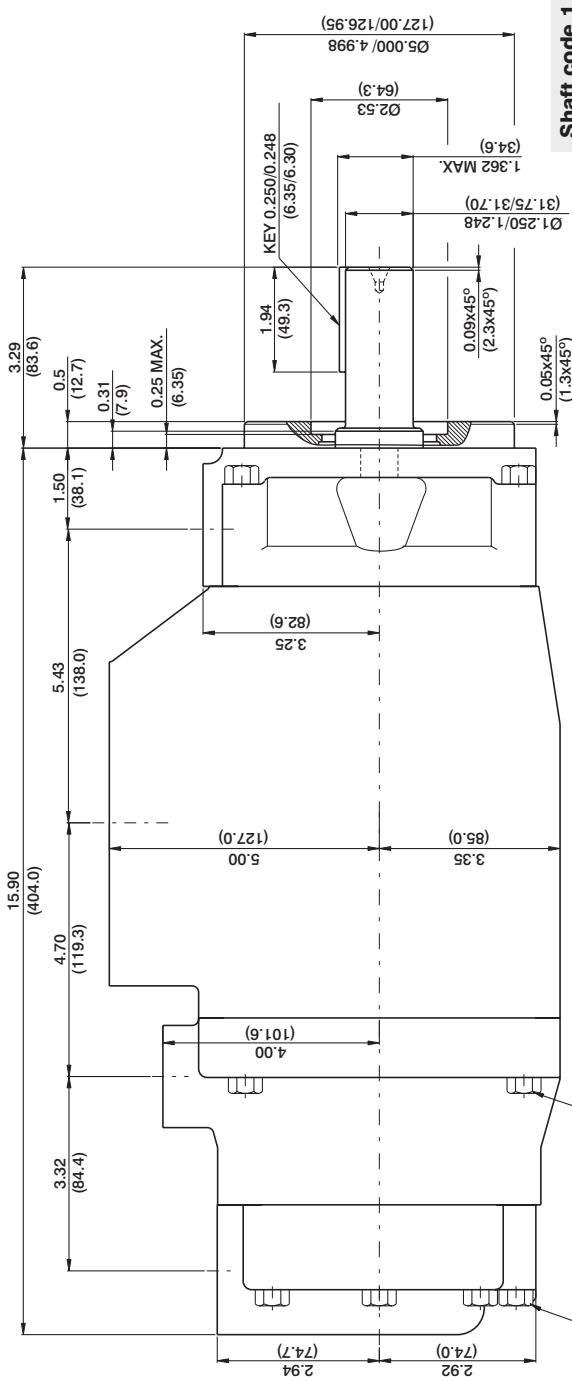
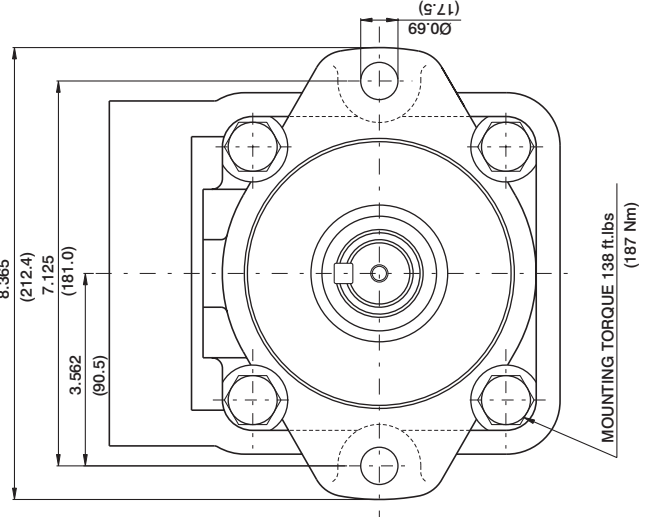

**Shaft code 1**  
(keyed no SAE)

**Shaft torque limits in<sup>3</sup>/rev x psi (ml/rev x bar)**

Shaft	Vp x p max. (P1 + P2 + P3)
1	38299 (43240)
2	58901 (66500)
3	54027 (61200)
4	58901 (66500)

MOUNTING TORQUE 138 ft.lbs (187 Nm)  
MOUNTING TORQUE 50 ft.lbs (68 Nm)