

VT7DD or VT7DDS - B42 - B22 - 1 R 00 - A 1 M0 -

Series

VT7DD series-ISO 4 bolts 3019-2
Mounting flange 125 B4 HW
VT7DDS series- SAE C 6 bolts
Mounting flange J744

Camring for "P1" & "P2"

Volumetric displacement cm³/rev (in³/rev)

B14 = 43.9 (2.68)	B31 = 99.1 (6.05)
B17 = 55.0 (3.36)	B35 = 113.4 (6.92)
B20 = 66.0 (4.03)	B38 = 120.6 (7.36)
B22 = 70.3 (4.29)	B42 = 137.5 (8.39)
B24 = 81.1 (4.95)	045 = 145.7 (8.89)
B28 = 89.9 (5.49)	050 = 157.9 (9.64)

Type of shaft VT7DDS

- 1 - keyed (SAE C)
- 2 - keyed (SAE CC)
- 3 - splined (SAE C)
- 4 - splined (SAE BB)

Type of shaft VT7DD - VT7DDS

- 5 - keyed (ISO 3019-2-G32M)

Modifications

Mounting w/connection variables

4 bolts SAE flange (J518)

P1 & P2= 11" S = 4"	
	UNC METRIC
VT7DD	M0
VT7DDS	00 M0

Seal class

- 1 - S1 (for mineral oil)
- 4 - S4 (for fire resistant fluids)
- 5 - S5 (for mineral oil and fire resistant fluids)

Design letter

Porting combination (see page BM-1-5)

00 - standard

Direction of rotation (view on shaft end)

- R - clockwise
- L - counter-clockwise

INTERNAL LEAKAGE (TYPICAL)

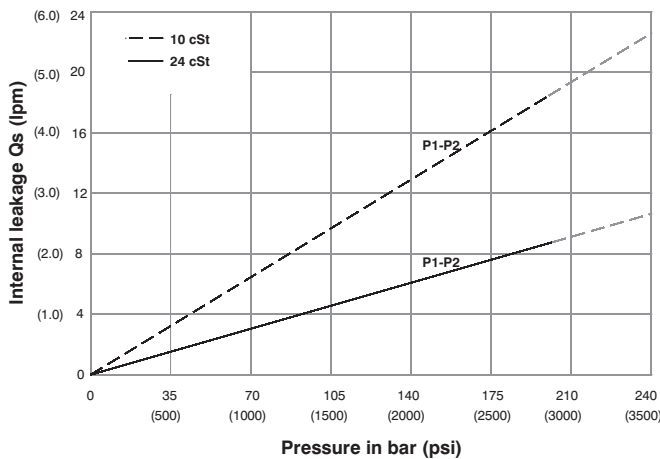

Do not operate pump more than 5 seconds at any speed or viscosity if internal leakage is more than 50% of theoretical flow. Total leakage is the sum of each section loss at its operating conditions.

NOISE LEVEL (TYPICAL)

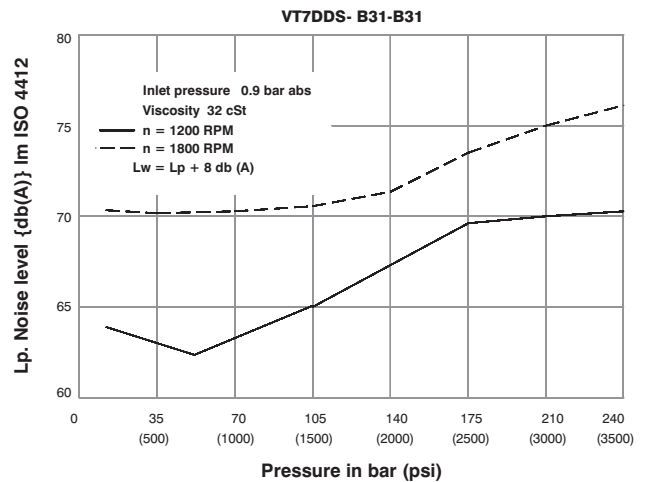

Double pump noise level is given with each section discharging at the pressure noted on the curve.

HYDROMECHANICAL POWER LOSS (TYPICAL)

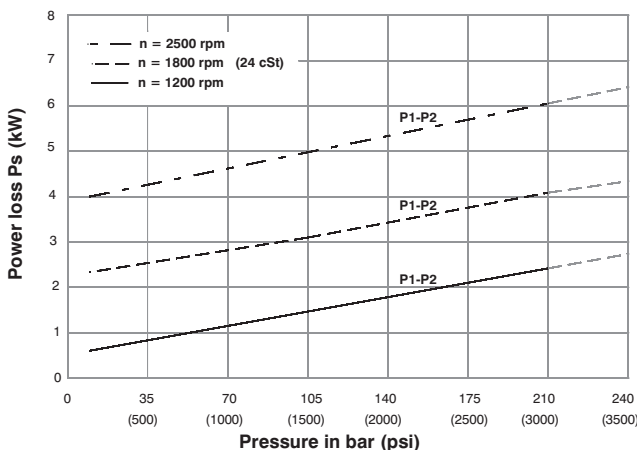

Total hydrodynamic power loss is the sum of each section at its operating conditions.

PERMISSIBLE RADIAL LOAD

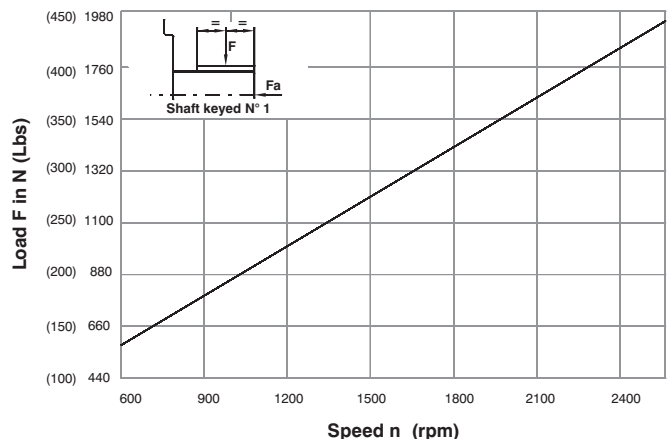

Maximum axial load permissible Fa = 800 N (180 Lbs)



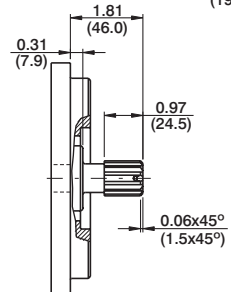
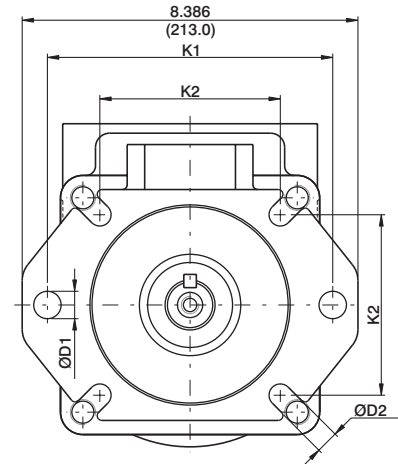
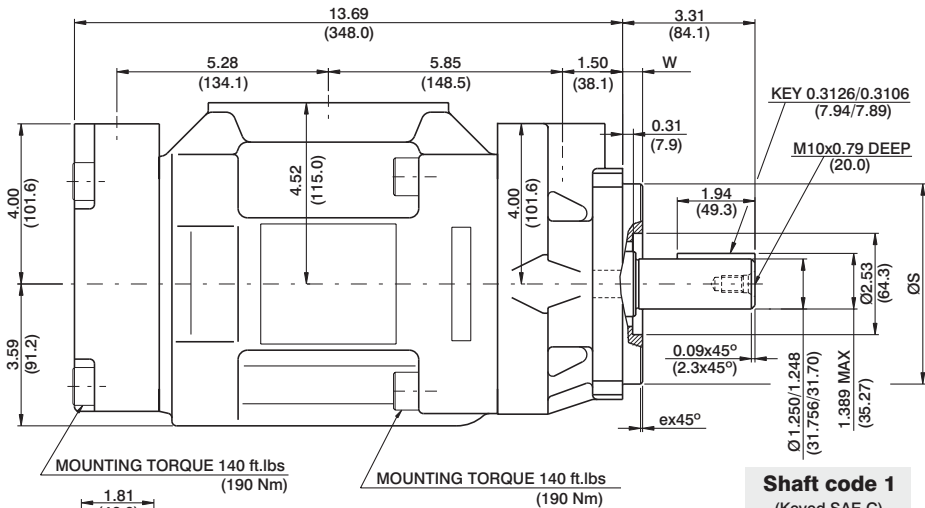
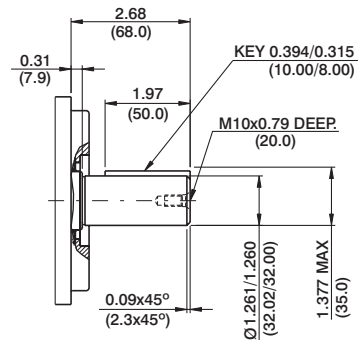
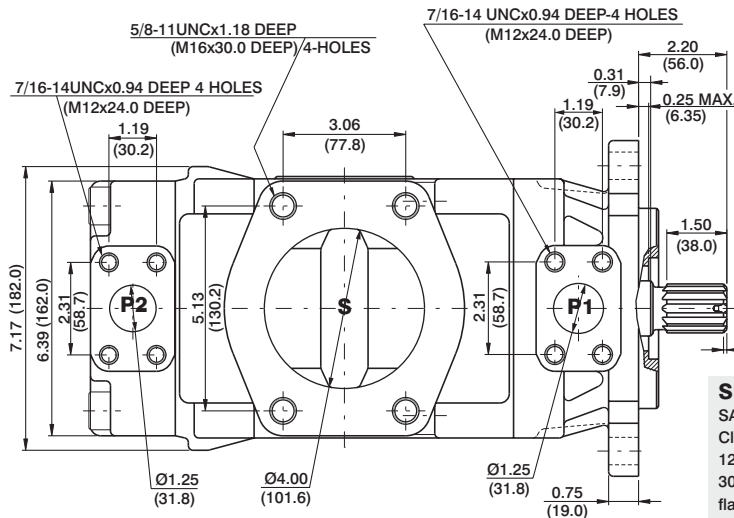

Shaft torque limits in ³ /rev x psi (ml/rev x bar)	
Shaft	Vp x p max. (P1+P2)
1	38299 (43240)
2	63552 (71822)
3	54207 (61200)
4	31780 (28120)
5	40035 (35424)

Alternate mounting flange								
Series	ØS		ex45°	W	K1	ØD1	K2	ØD2
	MAX.	Min.						
VT7DD	4.921 (124.99)	4.919 (124.94)	0.079 (2.0)	0.374 (9.49)	7.087 (180.0)	0.709 (18.0)	4.454 (113.1)	0.551 (13.9)
VT7DDS	5.00 (127.00)	4.998 (126.94)	0.059 (1.5)	0.50 (12.7)	7.126 (181.0)	0.689 (17.5)	4.508 (114.5)	0.563 (14.3)

OPERATING CHARACTERISTICS - TYPICAL (24 cST) (Input power p (KW) for one cartridge only)

Pressure port	Series	Volumetric Displacement Vp		Flow q & n = 1800 rpm						Input power p & n = 1800 rpm					
		in ³ /rev		p = 0 bar (0 psi)		p = 140 bar (2000 psi)		p = 250 bar (3630 psi)		p = 7 bar (100 psi)		p = 140 bar (2000 psi)		p = 250 bar (3630 psi)	
		gpm	lpm	gpm	lpm	gpm	lpm	gpm	lpm	hp	kw	hp	kw	hp	kw
P1 & P2	B14	2.68	43.9	20.92	79.1	19.18	72.5	17.81	67.3	3.46	2.6	27.77	20.7	47.03	35.07
	B17	3.36	55.0	26.16	98.8	24.41	92.3	23.04	87.0	3.77	2.8	33.88	25.3	57.71	43.03
	B20	4.03	66.0	31.39	118.6	29.64	112.0	28.27	106.8	4.07	3.0	39.98	29.8	68.39	50.99
	B22	4.29	70.3	33.43	126.4	31.69	119.8	30.32	104.6	4.19	3.1	42.37	31.6	72.57	54.11
	B24	4.95	81.1	38.57	145.8	36.82	139.2	35.45	134.0	4.49	3.4	48.36	36.1	83.06	61.93
	B28	5.49	89.9	42.80	161.8	41.06	155.2	39.69	150.0	4.74	3.5	53.30	39.7	91.70	68.38
	B31	6.05	99.1	47.18	178.3	45.43	171.7	44.06	166.5	4.99	3.7	58.41	43.6	100.63	75.03
	B35	6.92	113.4	53.93	203.9	52.18	197.2	50.81	192.0	5.39	4.0	66.29	49.4	114.42	85.32
	B38	7.36	120.6	57.35	216.8	55.61	210.2	54.24	204.9	5.59	4.2	70.27	52.4	121.42	90.54
	B42	8.39	137.5	65.39	247.2	63.65	240.6	62.28	235.4	6.05	4.5	79.66	59.4	137.83	102.77
	O45	8.89	145.7	69.29	262.0	67.11	253.6	65.31	246.8	6.74	5.0	83.75	62.4	145.79	108.71
	O50	9.64	157.9	75.14	284.0	72.96	275.8	71.78 ¹⁾	271.3 ¹⁾	7.08	5.3	90.58	67.5	134.50 ¹⁾	100.30 ¹⁾

1) 050 = 210 bar (3000 psi) max. int