

VTXBB 1 - B09 - B11 - 1 R 00 - D 1 02 *

Series

Mounting

- 1 - SAE A
- 2 - SAE B

Camring for "P1" & "P2"

Volumetric displacement cm^3/rev (in^3/rev)

- B02 = 5.8 (0.35)
- B03 = 9.8 (0.59)
- B04 = 12.8 (0.78)
- B05 = 15.9 (0.97)
- B06 = 19.8 (1.21)
- B07 = 22.5 (1.37)
- B08 = 24.9 (1.52)
- B09 = 28.0 (1.71)
- B10 = 31.8 (1.94)
- B11 = 34.9 (2.13)
- B12 = 41.0 (2.50)
- B14 = 45.0 (2.75)

Type of Shaft

- 1 - Keyed (Non SAE)
- 3 - Splined

Direction of rotation (view on shaft end)

- R - clockwise
- L - counter-clockwise

Modifications

Port connections

CODE	S	P1 & P2
00	2" SAE 4 bolt (UNC)	SAE 12 1 1/16" 12 UNF-2B
01		3/4" SAE 4 bolt (UNC)
M0	2" SAE 4 bolt (METRIC)	3/4" SAE 4 bolt (METRIC)

Seal class

- 1 - S1 (for mineral oil)
- 4 - S4 (for fire resistant fluids)
- 5 - S5 (for mineral oil and fire resistant fluids)

Design letter

Porting combination

00 - standard

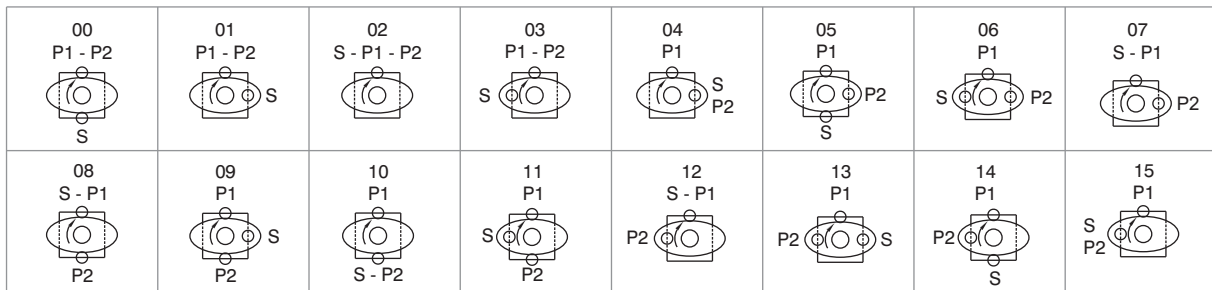

S: Suction port P1 & P2 : Pressure ports

OPERATING CHARACTERISTICS - TYPICAL (24 cST) (Input power p (KW) for one cartridge only)

Pressure port	Series	Volumetric Displacement Vp		Flow q & n = 1500 rpm						Input power p & n = 1500 rpm					
		in^3/rev	cm^3/rev	p = 0 bar (0 psi)		p = 140 bar (2000 psi)		p = 210 bar (3000 psi)		p = 7 bar (100 psi)		p = 140 bar (2000 psi)		p = 210 bar (3000 psi)	
				gpm	lpm	gpm	lpm	gpm	lpm	hp	kw	hp	kw	hp	kw
P1 & P2	B02	0.35	5.8	2.30	8.7	1.4	5.9	--	--	0.53	0.4	2.81	2.1	--	--
	B03	0.59	9.8	3.88	14.7	2.9	11.9	--	--	0.67	0.5	3.62	2.7	--	--
	B04	0.78	12.8	5.08	19.2	4.33	16.4	3.97	15.0	0.93	0.7	5.23	3.9	10.06	7.5
	B05	0.97	15.9	6.31	23.8	5.55	21.0	5.18	19.6	1.00	0.75	6.64	4.9	11.2	8.3
	B06	1.21	19.8	7.85	29.7	7.12	26.9	6.66	25.2	1.07	0.8	8.05	6.0	12.34	9.2
	B07	1.37	22.5	8.92	33.7	8.17	30.9	7.80	29.5	1.20	0.9	9.05	6.7	14.02	10.4
	B08	1.52	24.9	9.89	37.4	9.15	34.6	8.78	33.2	1.34	1.0	10.05	7.5	15.69	11.7
	B09	1.71	28.0	11.11	42.0	10.37	39.2	10.00	37.8	1.47	1.1	11.94	8.9	23.60	17.6
	B10	1.94	31.8	12.61	47.7	11.87	44.9	11.51	43.5	1.6	1.2	13.0	9.7	26.0	19.6
	B11	2.13	34.9	13.85	52.3	13.09	49.5	12.72	48.1	1.7	1.3	14.0	10.5	28.0	21.0
	B12	2.50	41.0	16.27	61.5	15.53	58.7	*	*	1.8	1.4	15.02	11.2	*	*
	B14	2.75	45.0	17.86	67.5	17.12	64.7	**	**	2.1	1.6	15.42	11.5	**	**

-- Not to use because internal leakage greater than 50% of theoretical flow.

* B12= 210 bar(3000 psi) Max.Int

** B14= 175 bar(2500 psi) Max.Int

INTERNAL LEAKAGE (TYPICAL)

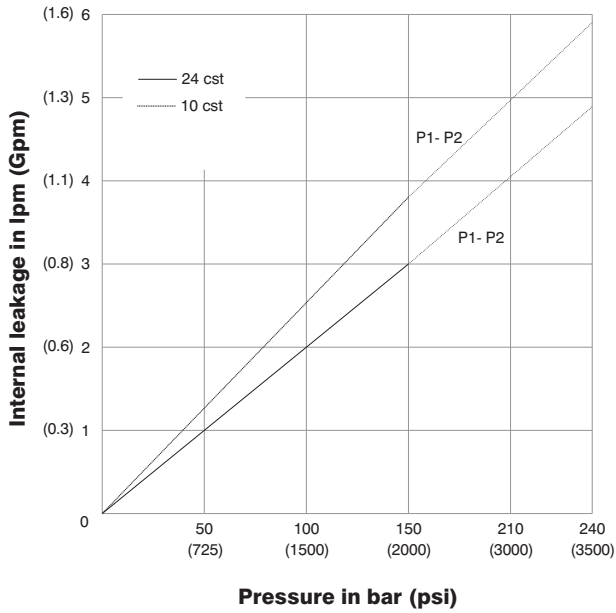

NOISE LEVEL (TYPICAL) VTXBB- B10-B09

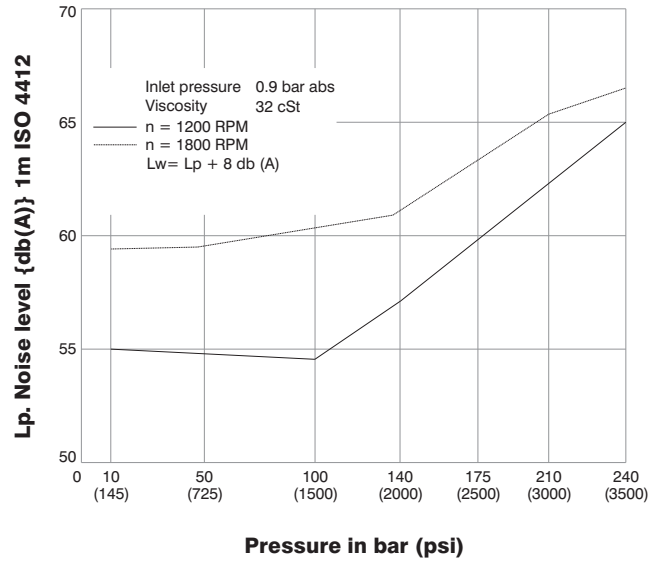

Do not operate pump more than 5 seconds at any speed or viscosity if internal leakage is more than 50% of theoretical flow. Total leakage is the sum of each section loss at its operating conditions.

Double pump noise level is given with each section discharging at the pressure noted on the curve.

HYDROMECHANICAL POWER LOSS (TYPICAL)

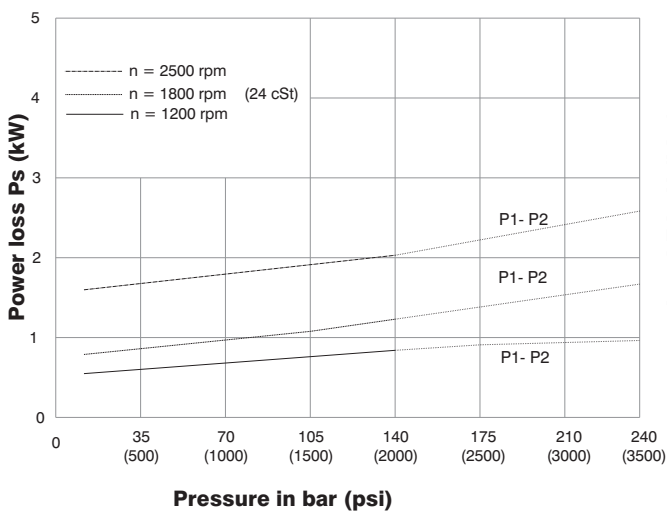

PERMISSIBLE RADIAL LOAD

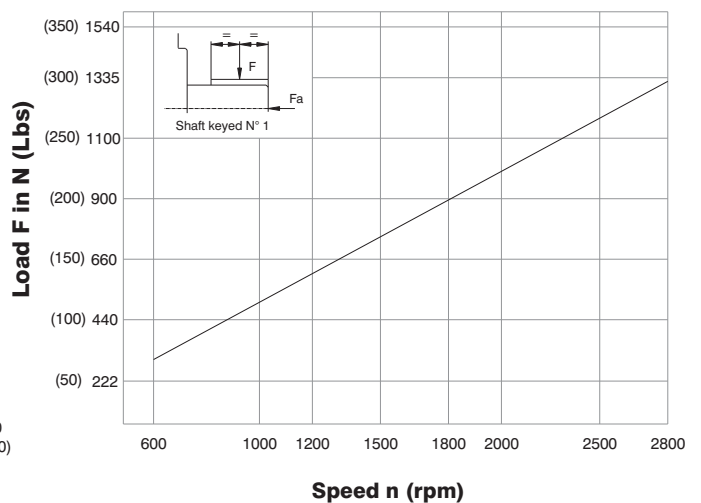

Total hydromechanical power loss is the sum of each section at its operating conditions.

Maximum permissible axial load $F_a = 800\text{N}$ (180 lbs)

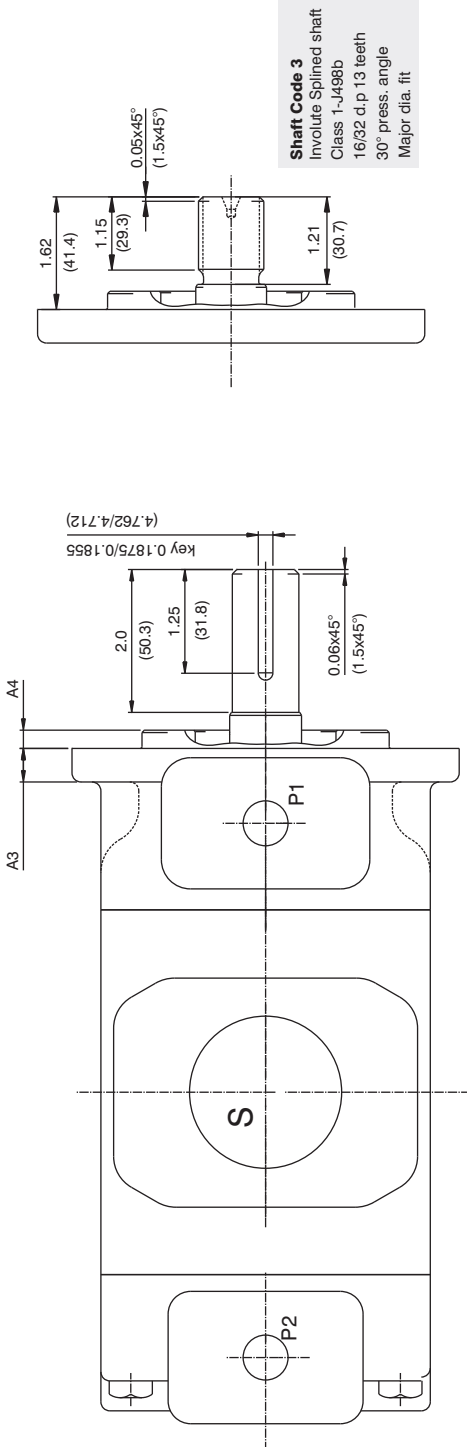

Shaft Code 3
 Involute Splined shaft
 Class 1-J498b
 16/32 d.p 13 teeth
 30° press. angle
 Major dia. fit

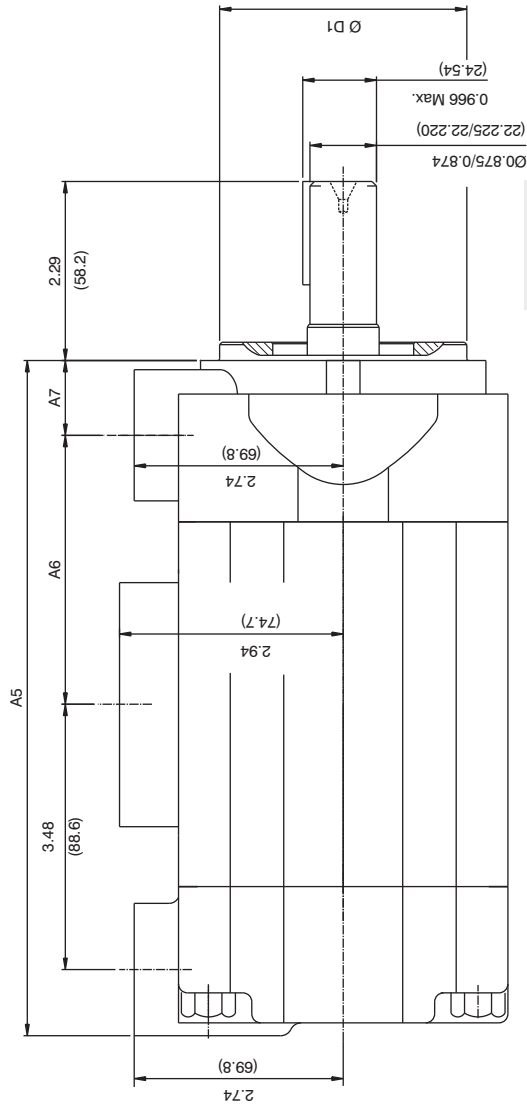
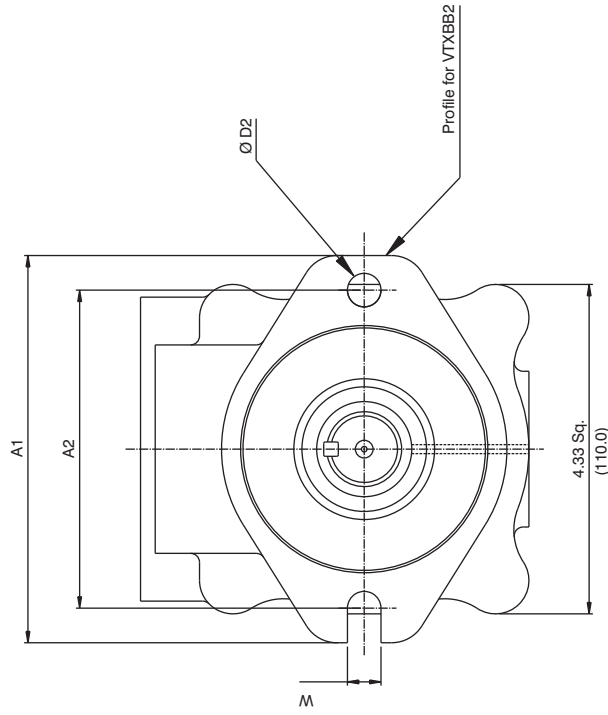

Shaft Code 1
 (keyed non SAE)

DIMENSIONS																				
MODEL	A1		A2		A3		A4		A5		A6		A7		ØD1		W		ØD2	
	inches	mm	inches	mm	inches	mm	inches	mm	inches	mm	inches	mm	inches	mm	inches	mm	inches	mm	inches	mm
VTXBB1	5.11	130	4.18	106.2	0.44	11.2	0.24	6.1	8.85	225	3.53	89.9	0.98	25	3.25/3.24	82.55/82.50	0.44	11.2	--	--
VTXBB2	6.87	174.5	5.74	146	0.5	12.7	0.37	9.4			3.36	85.4	1.22	31	4.00/3.99	101.60/101.55	--	--	0.56	14.3

Port Connection : 00

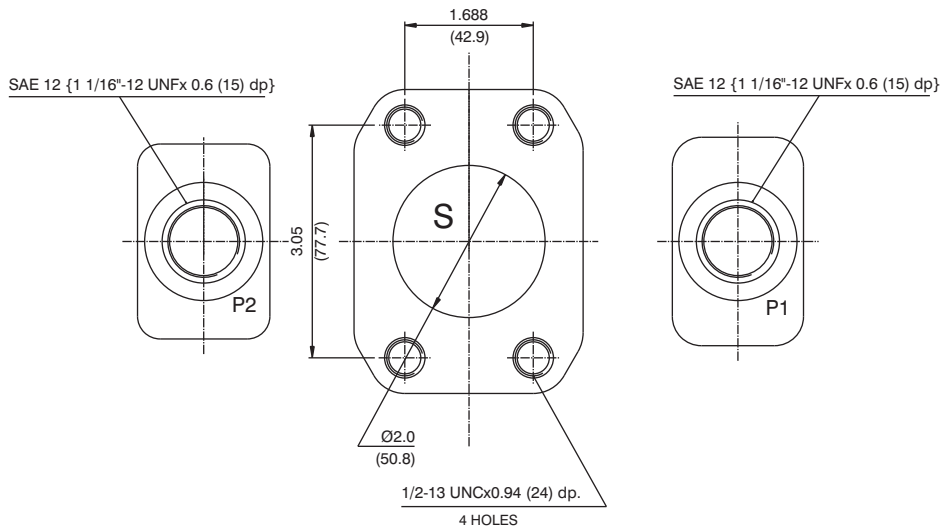

Port Connection : 01

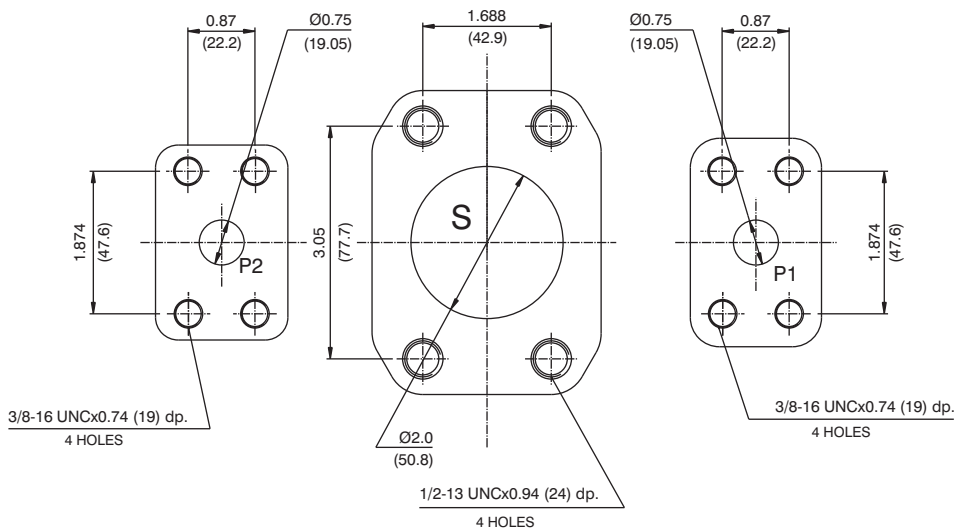

Port Connection : M0

